

Torsional

In This Section:

- Selection Process
- L-LOC Clamping Feature
- LF Series
- LVK Series
- LV Series
- LM Series
- LK Series
- Pump Mounting Plates
- Pump Mounting Housings





Torsional

Safety Warning

When using Lovejoy products, you must follow these instructions and take the following precautions. Failure to do so may cause the power transmission product to break and parts to be thrown with sufficient force to cause severe injury or death.

Refer to this Lovejoy Catalog for proper selection, sizing, horsepower, torque range, and speed range of power transmission products, including elastomeric elements for couplings. Follow the installation instructions included with the product, and in the individual product catalogs for proper installation of power transmission products. Do not exceed catalog ratings.

During start up and operation of power transmission product, avoid sudden shock loads. Coupling assembly should operate quietly and smoothly. If coupling assembly vibrates or makes beating sound, shut down immediately, and recheck alignment. Shortly after initial operation and periodically thereafter, where applicable, inspect coupling assembly for: alignment, wear of elastomeric element, bolt torques, and flexing elements for signs of fatigue. Do not operate coupling assembly if alignment is improper, or where applicable, if elastomeric element is damaged or worn to less than 75% of its original thickness.

Do not use any of these power transmission products for elevators, man lifts, or other devices that carry people. If the power transmission product fails, the lift device could fall resulting in severe injury or death.

For all power transmission products, you must install suitable guards in accordance with OSHA and American Society of Mechanical Engineers Standards. Do not start power transmission product before suitable guards are in place. Failure to properly guard these products may result in severe injury or death from personnel contacting moving parts or from parts being thrown from assembly in the event the power transmission product fails.

If you have any questions, contact the Lovejoy Engineering Department at 1-630-852-0500.



Torsional

Table of Contents

	Running Page No.	Section Page No.
Overview.....	262	T-4
Engine Application > Selection Process.....	264	T-6
Industrial Application > Selection Process.....	266	T-8
Applications Service Factors > Selection Data.....	267	T-9
Coupling Selection Worksheet.....	268	T-10
L-LOC Clamping Feature and Spline Identification > Overview.....	269	T-11
LF Series > Overview.....	270	T-12
LF Series – Elements > Overview.....	271	T-13
LF Series – Base Element, Models 1, 1/S, 2 and 2/S > Selection Data.....	272	T-14
LF Series – Models 3, 3/S, 6, 6/S and 6B > Selection Data.....	273	T-15
LF Series > Performance Data.....	274	T-16
LF Series – Base Element and Model 1 > Dimensional Data.....	276	T-18
LF Series – Models 1/S, 2 and 2/S > Dimensional Data.....	277	T-19
LF Series – Models 3 and 3/S > Dimensional Data.....	278	T-20
LF Series – Models 3, 3/S and Flywheel Housings > Dimensional Data.....	279	T-21
LF Series – Models 6, 6/S and 6B > Selection Process.....	280	T-22
LF Series – Models 6, 6/S and 6B > Dimensional Data.....	281	T-23
LF Series – Models 6 and 6B > Maximum Length and Speed Data.....	282	T-24
LF Series – Weights and Mass Moment of Inertia.....	283	T-26
LF Series Floating-Shaft – Models 6 and 6B > Selection Process.....	285	T-27
LVK Series > Overview / Performance Data.....	286	T-28
LVK Series – SAE J620 Flywheel Application > Dimensional Data.....	287	T-29
LV Series > Overview / Performance Data.....	288	T-30
LV Series – SAE J620 Flywheel Application > Dimensional Data.....	289	T-31
LM Series > Overview.....	290	T-32
LM Series – Types SB, SC, SBE and SCE > Selection Data.....	291	T-33
LM Series – Types SB, SCA and SCB (HTR) > Performance Data.....	292	T-34
LM Series – Types SB, SCA and SCB (HTR) > Dimensional Data.....	293	T-35
LM Series – Types SBE and SCE (HTR) > Performance Data.....	294	T-36
LM Series – Types SBE and SCE (HTR) > Dimensional Data.....	295	T-37
LK Series > Overview / Performance Data.....	296	T-38
LK Series > Dimensional Data.....	297	T-39
Pump Mounting Plates – SAE J744 > Dimensional Data.....	298	T-40
Pump Mounting Plates – SAE J620 > Dimensional Data.....	299	T-41
Pump Mounting Housings – Overview.....	300	T-42

Torsional Couplings

Lovejoy offers a wide range of torsional couplings engineered to solve torsional vibration problems found in diesel engine driven equipment and other applications where torsional vibrations are prevalent. These include all internal combustion engines, reciprocating pumps and compressors, as well as variable frequency drives (VFD).

Lovejoy torsional coupling are designed to dampen torsional vibrations and tune, or adjust the system's critical speeds away from the application's operating range. With the proper information (see Torsional Worksheet on page T-10) Lovejoy engineers can perform a Torsional Vibration Analysis, or TVA for your application to assist in the selection of a torsional coupling. See sample TVA in the graph to the right.

Lovejoy System Torsional Vibratory Load vs Operating Speed

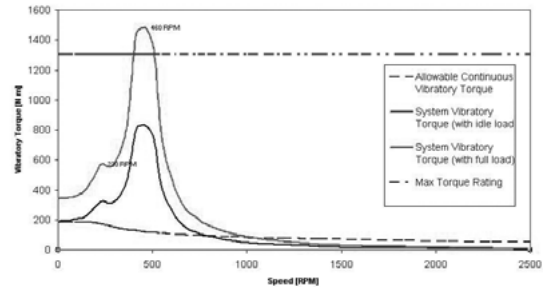

Lovejoy Torsional Coupling Product Overview

LF Series

The unique and highly versatile design of the elastomeric element makes the LF Series the most versatile product in Lovejoy's line of torsional coupling products. It is available in high temperature rubber (HTR), Hytrel®, or Zytel®. The element can be easily mounted in a number of configurations depending on the application. The element is connected axially to a flanged hub, flywheel adapter plate, or flywheel on the engine side using axial screws or special "S" bolts designed for blind assembly. The element is also connected to a cylindrical hub on the driven equipment side using radial screws. This unique design is remarkably simple, highly effective and provides users of LF torsional couplings with unmatched performance. It is recommended that coupling selections should be verified with a Torsional Vibration Analysis of the system (see page T-10).



- Configuration:** Flange to shaft, shaft to shaft, and floating shaft applications
- Application:** The LF coupling is ideal for coupling engines to pumps, compressors, generators, fans, blowers, and other industrial driven equipment connecting to either the engine flywheel or a power take-off (PTO).

- Nominal torque range (T_{KN}):** up to 26,500 in-lb (3000 Nm)
- Max angular misalignment (K_w):** HTR up to 3°, Hytrel® and Zytel® see table on page T-17
- Max parallel misalignment (K_R):** HTR up to 0.08 inches (2 mm), Hytrel® and Zytel® see table on page T-17
- Axial end float (K_a):** HTR up to 0.2 inches (5 mm), Hytrel® and Zytel® see table on page T-17
- Element material:** HTR, Neoprene, Hytrel® or Zytel®

LVK Series

The LVK Series torsional couplings accommodate configurations where internal combustion engines are connected to a variety of driven equipment, while protecting the equipment from potentially damaging torsional vibrations by tuning engine critical speeds away from the application operating speed. It is recommended that coupling selections should be verified with a Torsional Vibration Analysis of the system (see page T-10).

- Configuration:** The LVK Style couplings are designed for mounting on standard SAE J620 flywheels. The element is bonded to the flywheel mounting plate and the unique 'star' shaped LK Style hub housing. The mating hub mounts onto the equipment shaft and slides into an interlocking position during installation for a blind assembly.
- Application:** The LVK coupling is ideal for coupling engines to pumps, compressors, generators, fans, blowers and other equipment requiring a direct interface via the engine flywheel.

- Nominal torque range (T_{KN}):** up to 5,800 in-lb (655 Nm)
- Max angular, parallel, and axial misalignment:** based on SAE design parameters
- Element material:** High Temperature Rubber (HTR) or EPDM



WARNING
 You must refer to page T-2 (Page 260) for Important Safety Instructions and Precautions for the selection and use of these products. Failure to follow the instructions and precautions can result in severe injury or death.

WARNING
 Do not use anaerobic adhesives with any Torsional components.

LV Series

The LV Series torsional couplings provide an inexpensive and economical alternative for the agricultural and off-highway industrial equipment market. The standard configuration is used for connecting internal combustion engines to a variety of driven equipment through a specially designed plate manufactured which can support universal joint drive shaft systems. It protects the equipment from potentially damaging torsional vibrations by tuning engine critical speeds away from the application operating speed. It is highly recommended that coupling selections should be verified with a Torsional Vibration Analysis of the system (see page T-10).

Configuration: The LV Series couplings are designed for mounting on standard SAE J620 flywheels with the element bonded to the mounting plate. The face plate is specially designed to interface with flange mounted universal joints popular in the agricultural deep well pump markets.

Application: Any diesel engine driven equipment, flange interfaces, and universal joint driveshaft driven equipment.

Nominal torque range (T_{KN}): up to 10,820 in-lb (1223 Nm)

Max angular, parallel, and axial misalignment: based on SAE design parameters

Element material: High Temperature Rubber (HTR) or EPDM



LM Series

The Lovejoy LM Series torsional couplings are designed specifically for diesel driven applications where the couplings are flywheel mounted. The LM coupling is popular in small to large equipment configurations where it is necessary to protect the equipment from potentially damaging torsional vibrations. This is accomplished by tuning engine critical speeds away from the application operating speed. It is highly recommended that coupling selections should be verified with a Torsional Vibration Analysis of the system (see page T-10).

Configuration: Drive rings are designed for many SAE J620 flywheel sizes and mount directly on the flywheel. The element and center hub mount on the driven equipment shaft and easily slide into the drive ring. This coupling is excellent for normal or blind installations.

Application: Any diesel driven equipment that includes generator sets (2 bearing), hydraulic pumps (single or multiple in parallel or series configurations), locomotive applications, centrifugal pumps, compressors, fans, blowers, and more.

Nominal torque range (T_{KN}): up to 33,600 in-lb (3800 Nm)

Max angular, parallel, and axial misalignment: based on SAE design parameters

Element material: HTR, EPDM or Silicone



LK Series

The LK Series coupling is a simple two-piece design consisting of an flywheel or flange mounted element and an interlocking hub. The couplings are designed for use with diesel engine driven hydraulic pump systems which are plate mounted directly to SAE flywheel housings. The couplings are torsionally stiff enabling hydraulic pumps and similar equipment with low mass or inertia to operate below critical speeds. The torsionally stiff LK Series coupling tunes the engine critical speed away from the operating range. A Torsional Vibration Analysis is typically not necessary for the LK Style couplings because the LK Series is torsionally stiff and puts the critical speed above the normal operating range.

Configuration: The LK Series coupling consists of a flywheel mounted element, or an adapter plate mounted universal element, and a star shaped hub. The hub is mounted on the driven equipment and its design is excellent for blind installations.

Application: The LK coupling's design is excellent for virtually all diesel engine driven hydraulic systems in the low to mid power range.

Nominal torque range (T_{KN}): up to 21,240 in-lb (2400 Nm)

Max angular, parallel, and axial misalignment: based on SAE design parameters

Element material: Zytel®

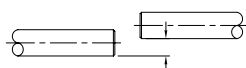

Parallel Misalignment

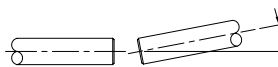

Angular Misalignment

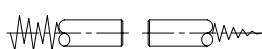

Torsional Misalignment

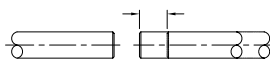

Axial Misalignment

When correctly sized, the Lovejoy Torsional Coupling will effectively dampen vibration and tune critical frequencies out of the operating range of systems driven by diesel, gasoline, or natural gas reciprocating engines. Some coupling selections can be verified using a Torsional Vibration Analysis performed by Lovejoy Engineering (see worksheet page T-10).

Misapplication of the coupling in an engine application will frequently lead to coupling failure or system damage. Lovejoy strongly recommends that you contact Technical Support for assistance in selecting a coupling.

Please complete the information worksheet on page T-10 and fax it to 800-446-0878 or access "Engineering Assistance" on-line at www.lovejoy-inc.com

Use the following steps in conjunction with the technical data and dimensional tables contained in the following sections to make the preliminary coupling selection for internal combustion engine applications.

Step 1: Coupling Selection

Select the torsional coupling model that best suits your drive arrangement.

Step 2: Application Torque

Select a coupling size with a nominal torque rating (T_{KN}) greater or equal to the application torque (T_{LN}) calculated with the following equation:

$$T_{KN} \geq T_{LN} \cdot S_t$$

Provided $T_{LN} \text{ (in-lb)} = \text{HP} \cdot 63025 / \text{RPM}$
 or

$$T_{LN} \text{ (Nm)} = \text{HP} \cdot 9555 / \text{RPM}$$

S_t is the temperature factor for the nominal torque found in Figure 1 (page T-9) for HTR. This number will be at least 1.6 or 1.7 (for typical ambient temperature of at least 140° to 160° F inside the flywheel housing).

Step 3: SAE Flywheel Size

Select the appropriate SAE J620 flange size to match your flywheel.

Step 4: Shaft Dimensions

Make sure the maximum bore capacity of the coupling will accommodate the dimensions of your drive shaft. Coupling hub length can usually be shortened if necessary to fit into tight space envelope.

Important:

Final selection of coupling size requires verification by torsional vibration analysis. This analysis will identify the location of the critical speeds and confirm the absence of excessive steady-state and peak resonance conditions over the normal operating cycle of the equipment.

Step 5: Peak Torque Pulses

The magnitude of the maximum torque pulses that occur during operation (T_{max}) at all operating temperatures must not exceed the maximum torque rating of the coupling (T_{Kmax}). These are short duration transient pulses that result from start-up, shock, or acceleration through a system resonance to reach operating speed. By definition, these pulses may occur over the life of the coupling 10^5 times in one direction of rotation, or 5×10^4 times reversing.

$$T_{Kmax} \geq T_{max} \cdot S_t$$

Step 6: Critical Speeds Due to Resonance

Select coupling stiffness so the system does not run at high resonance as well as the normal running and idle speeds are not at or near critical speeds.

Critical speeds are related to the system natural frequency and the number of pulses or excitations generated per revolution i (order). For analysis, if possible, reduce the application to a 2-mass system and apply the following equations:

$$n_R = \frac{60}{2\pi \cdot i} \sqrt{C_{Tdyn} \cdot \frac{J_A + J_L}{J_A \cdot J_L}}$$

Where:

- n_R = critical resonance speed of the system (RPM)
- C_{Tdyn} = dynamic torsional stiffness of the coupling (lb-in/rad)
- J_A = mass moment of inertia for the drive side (lb-in-sec²)
- J_L = mass moment of inertia for the load side (lb-in-sec²)
- i = number of oscillations generated per revolution

The coupling will be modeled as the spring controlling torsional oscillations of the engine and flywheel on one side and the driven equipment on the other:

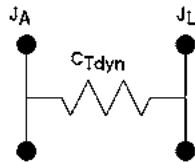

Use the dynamic torsional stiffness values (C_{Tdyn}) from the Performance Data tables which can be found in representative coupling section. Mass moment of inertia values may be obtained from the respective engine and equipment manufactures.

Note: ■ System steady-state operating speeds should be 1.5 to 2 times the major critical speed for safe, low-resonance operation.

Step 7: Allowable Continuous Vibratory Torque

The amplitude of the continuously oscillating (vibratory) torque generated in the system must not exceed the coupling's rating (T_{KW}) at a particular steady-state frequency (RPM) and temperature. This torque is superimposed on (co-exists with) the basic load (T_{LN}).

$$T_{KW} > T_w \cdot S_t \cdot S_f \cdot V$$

Where:

- T_{KW} = Coupling rating for continuously oscillating torque at 10Hz
- S_f = Frequency factor that relates the operating frequency to the coupling's 10Hz rating (see Figure 2 on page T-9)
- S_t = Temperature factor (for HTR only)
- V = Amplifying factor outside the resonance. Substitute V_r for V with run-through of resonance application (see Figure 3 on page T-9)
- T_w = Generating torque

Operating Frequency f (Hz)	≤ 10	>10
Frequency Factor S_f	1	$\sqrt{f/10}$

The magnitude of the continuously oscillating torque generated in the system (T_w) is dependent on an amplifying factor (V) based on the system steady-state operating speed n relative to the resonance speed n_R :

$$V \approx \frac{1}{|1 - (n/n_R)^2|}$$

Step 8: Dimensional & Alignment Considerations

Refer to the Performance Data tables, figures, and dimension tables to make certain final coupling selection meets application constraints for the working envelope (O.C., length, bore dimensions, etc.), maximum speed limitations and allowable misalignment.

While the Torsional coupler was developed to solve the unique problems associated with the torsional vibration in equipment driven by internal combustion engines, the coupling works equally well in general industrial applications. For these electric motor-powered and other non-engine applications, use the following simple selection procedure (Refer to page T-6 for engine-driven applications).

Misapplication of the coupling in an engine application will frequently lead to coupling failure or system damage. Lovejoy strongly recommends that you contact Technical Support for assistance in selecting a coupling.

Please complete the information worksheet on page T-10 and fax it to 800-446-0878 or access "Engineering Assistance" on-line at www.lovejoy-inc.com

Use the following steps in conjunction with the technical data and dimensional tables contained in the following sections to make the preliminary coupling selection for industrial applications.

Step 1: Coupling Selection

Select the torsional coupling model that best suits your drive arrangement.

Step 2: Choose Element Material

Most common used is the HTR (High Temperature Rubber) element is used because of the high flexibility. This feature provides benefits of vibration and shock damping, noise silencing, and a high tolerance for misalignment.

When required, the Zytel® element provides a torsionally rigid connection yet is still flexible in terms of accommodating small angular misalignment as well. Use of the floating-shaft Model 6 version will allow for parallel misalignment as well. The Zytel® material is also chemical resistant.

Please note that the optional Hytrel® element requires almost perfect alignment which is unlikely in most applications and is not recommended, except when used as intended on a flange mounted hydraulic pump to an engine flywheel.

Step 3: Determine Service Factor

Choose a representative application Service Factor (SF) from the chart on page T-9.

Step 4: Calculate Nominal Torque Requirement, T_{KN}

Use the actual torque or horsepower requirement for the driven equipment if known. Otherwise, use the rated motor horsepower.

$$T_{KN (in-lb)} \geq \text{HP} \cdot \text{SF} \cdot 63025 / \text{RPM}$$

Step 5: Other Considerations

Refer to the Performance Data tables, figures, and dimension tables to make certain final coupling selection meets application constraints for envelope (O.D., length, bore dimensions, etc.) and maximum speed limitations.

Example:

Find a LF coupling for a 15 hp centrifugal pump running at 1,750 RPM.

Model 2 – Most common for shaft-to-shaft applications.

Model 2/S – For shaft-to-shaft applications that require free end-float or quick, blind "plug-in" assembly.

Model 1 or 1/S – or connecting a shaft to a flange or flywheel.

Model 6 – floating shaft applications (see pages T-22 through T-25).

SF = 1.0 (from Application Service Factor (SF) on page T-9)

$$T_{KN} = (15\text{hp} \cdot 1.0 \cdot 63025) / 1,750 \text{ RPM} = 540 \text{ in-lb}$$

» use a LF8 torsional coupler or larger

Application Service Factors

Agitators	1.0
Beaters	1.5
Blowers	1.0-1.25
Can filling machinery	1.0
Car dumpers	2.5
Car pullers	1.5
Compressors (screw)	1.0
Compressors (reciprocating)	Consult Lovejoy
Conveyors	1.0-2.5
Love Roll, Shaker & Recip.	3.0
Conveyors (heavy duty)	1.25-2.5
Cranes & Hoists ¹	2.0
Crushers	3.0
Dredges	1.5-2.0
Elevators	1.0
Fans	1.0-1.5
Feeders	1.0
Reciprocating	2.5
Generators:	
Not Welding	1.0
Welding	2.0
Hoist	1.5
Hammer mills	2.0
Kilns	1.5
Laundry washers:	
Reversing	2.0
Line shafting	1.5
Lumber machinery	2.0
Machine tools	1.5-2.0
Metal forming machinery	1.5-2.5
Mills, rotary type	2.0
Mixers	1.5-1.8
Paper mill equipment	1.2-2.0
Pumps:	
Centrifugal	1.0
Gear, Rotary or Vane	1.25
Reciprocating 1 Cyl.	2.0
Or double acting	
2 Cyl. Single Acting	2.0
2 Cyl. Double Acting	1.75
3 or more Cyl.	1.5
Rubber machinery	2.0-2.5
Stokers	1.0
Textile machinery	1.2
Windlass	2.0
Woodworking machinery	1.0

Note: ■ 1 indicates: If people are transported, Lovejoy does not recommend and will not warranty the use of the coupling.

Figure 1: Temperature Factor*, S_t (HTR)

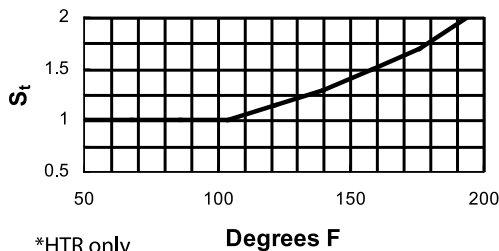

*HTR only

Figure 2: Frequency Factor

Operating Frequency f (Hz)	≤ 10	> 10
Frequency Factor S_f	1	$\sqrt{f/10}$

Figure 3: Resonance Factor V_r

Coupling Element	V_r	Ψ
HTR 50 Shore	10	0.6
HTR 60 Shore	8	0.78
Hytrel®	—	0.5
Zytel®	—	0.4

Note: ■ HTR is High Temperature Rubber.

Figure 4: Permissible Misalignment vs. Speed

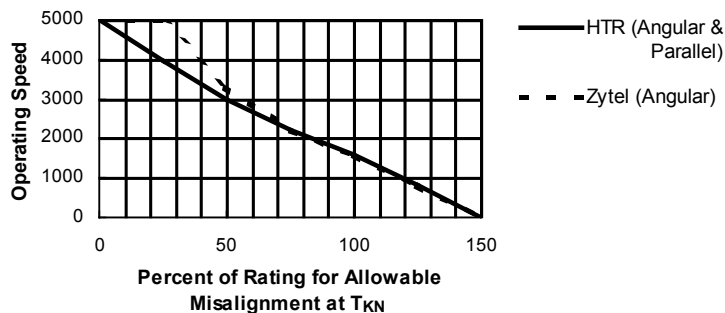

Chemical Resistance Chart

Oils & Hydraulic Fluids	Hytrel®	Zytel®	Solvents & Fuels	Hytrel®	Zytel®	Acids & Bases	Hytrel®	Zytel®	Miscellaneous	Hytrel®	Zytel®
Automatic Transmissions	A	A	Gasoline	A	A	Sulfuric Acid (20%)	A	C	Ethylene Glycol*	A	A,B
Fluid Type A & F	A	A	Nujol, JP4 Kerosene	A	A	Hydrochloric Acid (20%)	B	C	Steam	B	B
Hydraulic Fluid	A	A	Halocarbons, Freon	A	A	Potassium or Sodium	—	—	Liquid Ammonia	—	A
Phosphat Ester	A	A	Trichlorethylene	C	C	Hydroxide (20%)	A	B	—	—	—
Lube Oil	A	A	Carbon Tetrachloride	B	A	—	—	—	—	—	—

Notes: ■ Avoid contact with hydrocarbon base lubricants or use of any anaerobic adhesives.
 ■ A indicates: Little or no effect.
 ■ B indicates: Moderate effect.
 ■ C indicates: Severe effect.



Coupling Selection Worksheet

Coupling Selection Worksheet for Internal Combustion Engines (diesel, gas, natural gas)

For assistance in selecting a Torsional coupling for your internal combustion engine application, please complete the entire worksheet and fax it to 800-446-0878 or send via email to appleng@lovejoy-inc.com. Direct questions to 630-852-0500.

Customer Information

Date: _____

Company Name: _____ Contact Name: _____

Phone Number: _____ email address: _____

Fax Number: _____ Anticipated Order Quantity / Annual Usage: _____

Brief Description of Application: _____

Engine Information

Type:

Piston configuration

Engine Manufacturer: _____

Diesel

In-Line

Engine Model: _____

Gasoline

Vee Vee-angle: _____

Number of Cylinders: _____ Displacement: _____

Natural Gas

Rated Horsepower: _____

Other: _____

SAE (J620D)
Flywheel Size: _____
6-1/2, 7-1/2, 8, 10, 11-1/2, 14, 16, etc
(Attach Drawing if non standard)

@ Rated Speed: _____

2-Stroke 4-Stroke

Operating Speed (Constant): _____

Idle Speed: _____

SAE (J617C)
Flywheel Housing Size: _____
6, 5, 4, 3, 2 or 1

PTO Shaft or Output Shaft Diameter: _____

Driven Equipment

Hydraulic Pump

Shaft Diameter or Spline details

Driven From:

Water Pump

Flywheel

Compressor Type: _____
(Screw, Reciprocating, Lobe Etc)

Front / Side PTO

Other (Explain)

Generator / Alternator

Type of Equipment Mounting

Other: _____

Flange mount to engine pilot

Ambient Operating Temperature: _____ °F / °C

Independent of engine

Mass Moment of Inertia (J or WR²)

The following must be provided for Torsional Vibration Analysis. Please include type of units (J or WR²)

Engine Inertia: _____

Flywheel Inertia: _____

Driven Equipment Inertia(s): 1. _____ 2. _____ 3. _____ 4. _____

Add sketch or Mass Elastic Diagram if necessary

Return completed worksheet to Lovejoy Technical Support at email: appleng@lovejoy-inc.com or Fax to 800-446-0878

Lovejoy's L-LOC Spline Clamping Feature

Spline shaft wear, profile distortion, and fretting corrosion all are major concerns in spline shaft applications such as hydraulic pumps. We are pleased to state that Lovejoy has a solution. It's called the L-LOC.

It is common knowledge that typical manufacturing tolerances between spline shafts and mating coupling hubs create some unavoidable play or backlash. This backlash is defined as the minor movement between the shaft and hub, typically resulting in wear. This tolerance related movement and wear is often further compounded by misalignment and hammering forces common in power transmission. As a result, fretting wear and profile distortion can occur, even when shafts are manufactured with high quality hardened steel using tight tolerances. If not checked, abnormal stresses on seals, bearings, and other engine or pump components can occur. The results are costly 'down time'. A great deal of money is spent each year on maintenance caused by this premature wear and equipment failure.

The ideal solution to spline distortion and wear is to eliminate the backlash or clearance related to mating tolerances and assembly misalignment. There are many solutions available, but most are expensive, time consuming, and often unsuccessful causing additional damage.

Lovejoy coupling hubs with the L-LOC spline clamping feature have proven themselves successful by eliminating the backlash, clearance issues, and damage caused by the hammering effects of vibration, including torsional vibration. The result is longer lasting spline profiles in both shafts and couplings that decrease costly downtime.

The L-LOC feature is a remarkably simple, yet effective design, consisting of a unique 'dog bone' shaped slot that is placed slightly above and parallel to the spline bore. When these set screws are tightened, the hub becomes firmly locked in place, gripping the full diameter of the spline shaft and the set screws never come in contact with the spline. As a result, users will never see dents, gouges, or burrs on the shaft from mounting the hub. While in use the hub and shaft virtually become a single entity, yet when the set screws are loosened, the L-LOC releases its grip and the hub can be easily removed from the spline shaft.

Spline Identification and Selection

There are hundreds of combinations of splines used in industry today and, while Lovejoy does not stock all of these splines, many are maintained in inventory while a large variety can be quickly machined for your specific needs.

When identifying splines, it is important to know what Industry Standard the spline falls under such as ANSI B92.1A (SAE J744) or DIN5480. Manuals and data sheets provided by most original equipment manufacturers contain the necessary spine data for users to identify and order a hub with the proper spline.

Lovejoy's Customer Service and Technical Support teams can help pick out couplings or hubs containing most splines, but certain information will need to be provided prior to making the proper selection.

SAE Standard Involute splines are the most common spline in use in the United States and many are represented in the ANSI chart shown on the right. Information required to identify most ANSI (SAE) splines contains the number of teeth, the diametral pitch, and the major spline diameter. Lovejoy's ANSI splines are machined to meet the ANSI standard Class-5 fit.

When specifying DIN-5480 splines, it is necessary to provide the number of teeth, the major diameter in mm, and the DIN Module number, usually in format:

DIN 5480 x Major Dia x Module x Pressure angle (usually 30°) x number of teeth.

Lovejoy's DIN-5480 splines are machined to meet the DIN standard 9H fit.

DIN-5482 metric splines, JIS splines, and SAE J499 parallel side splines, can be quoted based on individual applications.



Features

- L-LOC eliminates premature spline shaft maintenance or replacement
- Reduces potentially damaging stress on equipment components
- Quick and easy to assemble and/or removal
- Improves the effectiveness of the connection between the hub and shaft
- Helps reduce equipment noise often related to couplings

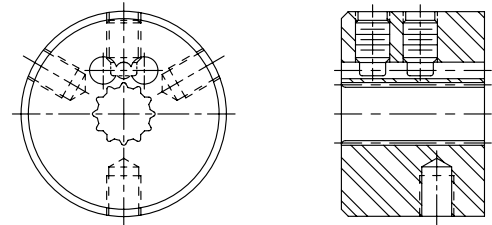

SAE Splines ANSI B92.1A (SAE J744)

SAE Code	Number of Teeth	Diametral Pitch (DP)	Major Diameter in
A-A	9	20/40	0.500
A	9	16/32	0.625
—	11	16/32	0.750
B	13	16/32	0.875
B-B	15	16/32	1.000
C	14	12/24	1.250
—	21	16/32	1.375
C-C	17	12/24	1.500
—	23	16/32	1.500
D	13	8/16	1.750
E	13	8/16	1.750
—	20	12/24	1.750
—	27	16/32	1.750
F	15	8/16	2.000

Note: ■ Please contact Lovejoy Technical Support regarding additional spline sizes not included in this chart.

LF Series Torsional Coupling

The LF Series coupling is designed with a unique and highly versatile elastomeric element. These can be easily integrated into a variety of coupling configurations to meet several application needs. LF Style elements are available in a variety of materials to match the necessary coupling dampening characteristics for tuning the systems critical speed away from the application operating speed. The element can be connected axially to a flywheel adapter plate or flanged hub and radially to a cylindrical center hub using the appropriate bolts. Axial bolt styles include either socket head bolts with a special dry adhesive, or S-Style bolts, which are similar to dowel pins (seen picture below). The radial bolts are used to connect the element to the cylindrical hub. This unique design is remarkably simple, highly effective and gives the LF torsional coupling unmatched performance capabilities. The coupling selection should be verified with a Torsional Vibration Analysis (TVA) of the system. The information required to perform a TVA can be found in the Coupling Selection Worksheet on page T-10.



Features

- Wide range of standard designs and materials
- Application versatility
- Shaft to shaft or flywheel to shaft designs
- Designed to accommodate substantial shock loads, vibration, and misalignment
- Low moment of inertia
- Electrically insulating
- No lubrication, maintenance free
- Unique air-flow cooling design
- Different element stiffness values allow for torsional tuning of applications with diesel engines
- Economic design allows for cost effective solutions for torsional applications
- Proven L-LOC spline-clamping hub virtually eliminates spline shaft profile wear and “fretting”
- Oil, heat, and corrosion resistant elements (Hytrel®, Zytel®)
- When used with S-bolts, the coupling can accommodate some end float.
- S-bolts accommodate applications requiring “blind” assembly
- Model 6 unique spacer designs span gaps between equipment in excess of the normal equipment separation
- Model 6 design available with bearings for high speeds and large amounts of equipment separation



Lovejoy's LF product line supports both standard style elements (above left) and the S-Style elements (above right). The standard style elements bolt to the cylindrical (center) hub and the flywheel, flywheel adapter, or flange hub. The S-Style utilizes bolts which look like dowel pins and are designed for “blind” installations, where the axial bolts may not be accessible for tightening during the installation process. One application would be inside a bell housing when all the components are assembled and the bolts cannot be reached. The S-Style bolts also accommodate a small amount of end float when necessary to prevent unnecessary axial stress on the element. When looking to replace elements, please note the difference in the axial holes. The standard elements have stepped holes to accommodate the cap screws (above left) which are used to mount the element. The S-Style elements have straight holes (above right) to accommodate the S-Style pins.

Further installation instructions can be found at www.lovejoy-inc.com in the Technical Resources section.

LF Series Torsional Elements

The focus of any coupling is the flexible elements, or the “working component”. The element must effectively absorb the shock loads, misalignment forces, and torsional vibrations, under a variety of environmental conditions. The following materials are used to accommodate the different conditions and environments where the couplings are used.

High Temperature Rubber (HTR)

There are two different rubber element materials available, High Temperature Rubber (HTR) and Neoprene (CR). Both elements are torsionally soft and are placed into compression during assembly. Rubber under compression can carry up to 5 times the amount of torque as non-compressed elements. The elements effectively accommodate shock, misalignment, and vibration plus minimize harmful radial and axial forces on the connected equipment. Neoprene (CR) is used in environments that are hostile to High Temperature Rubber (HTR).

Available Durometer Hardness : 50, 60 (Shore A scale)
 Operating Temperature Range: HTR: -40° to 194° F
 CR: -40° to 175° F
 Maximum Angular Misalignment: Up to 3°



HTR

Hytrel®

Elements made of DuPont’s Hytrel® elastomer compound are torsionally much stiffer than natural rubber (20 times stiffer) and were developed for combustion engine / hydraulic pump applications. Hytrel® elements have 20% greater torque capacity as compared to rubber elements. The torsionally stiff Hytrel® element moves the harmful vibration resonance frequency above the operating RPM range. The element design also reduces harmful radial and axial reactionary forces.

Operating Temperature Range: -60° to 250° F
 Maximum Angular Misalignment: 0.25°



Hytrel®

Zytel®

Elements made of DuPont’s highly stressable Zytel® elastomeric compound have excellent chemical compatibility and corrosion resistance. The element composition is 3-times stiffer than Hytrel® elements. Zytel® elements exhibit less than 1° wind up at normal torque and zero backlash. Most suited for applications where heat, moisture, high torque / high speed, and corrosion resistance are critical factors in the coupling selection.

Operating Temperature Range: -40° to 300° F
 Maximum Angular Misalignment: 1°



Zytel®

The following are standard LF Series torsional coupling models. The simple, unique design permits a wide range of models from common components to meet each application requirement.

Base Element

The heart of the LF Series coupling is the flexible base element. This element allows the customer to make their own shaft hubs from steel bar stock or use existing hubs. Ideal for quick prototype testing, retrofit and high volume applications.

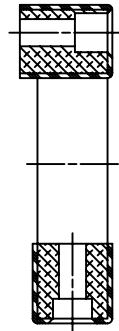

**Standard
Base Element**

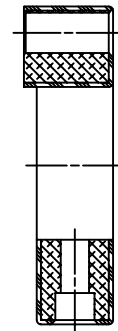

**S-Style
Base Element**

Model 1 and 1/S

Consists of the flexible base element with a simple steel cylindrical hub.

The 1/S is shown with the S-Style axial screw (similar to a dowel) for quick blind assembly of the drive package. The same combinations available in Model 1 are also available in the Model 1/S.

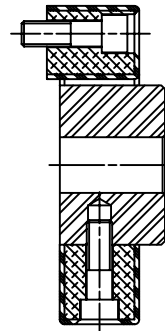

Model 1

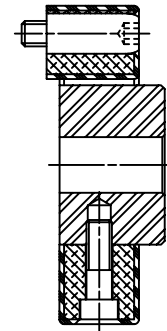

Model 1/S



Model 2 and 2/S

Provides a complete shaft-to-shaft coupling in a range of sizes for all industrial power transmission applications. It is similar to Model 1 shown above, except a flanged hub is added to make the shaft to shaft connection.

Model 2/S allows the drive package to be “blind” connected. As with all S-Style models, axial end float of equipment shafts can be accommodated without harmful push-pull force.

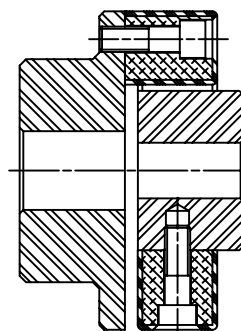

Model 2

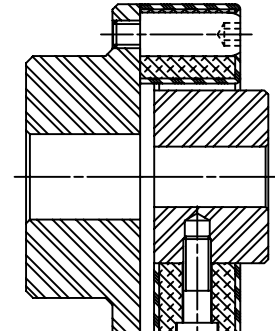

Model 2/S

Model 3 and 3/S

A Model 1 or 1/S with the addition of an engine mounting plate becomes a Model 3 or 3/S. It is available in standard SAE flywheel sizes as well as made-to-order sizes. The standard cylindrical hub is available in a variety of ANSI (SAE), DIN, JIS, and agricultural spline bores for hydraulic pumps and other applications. Various standard flexible element materials are available for specific torsional, misalignment and environmental requirements.

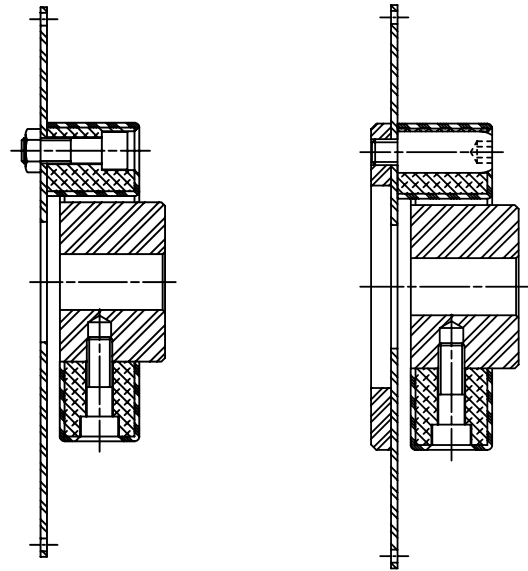

Model 3

Model 3/S

Model 6, 6/S and 6B

The Model 6 is available with floating shafts at customer specified assembly lengths, with special corrosion and heat resistant elements and materials. This model surpasses all other floating shaft designs in assembly, simplicity and reliability. Model 6/S accommodates free endplay without harmful push-pull reaction forces. Model 6/B is a highly elastic floating shaft coupling with accurate, maintenance free centering flanges for applications with long spans and high misalignment and or speed requirements.

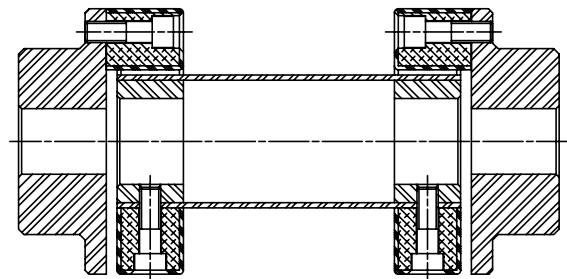

Model 6

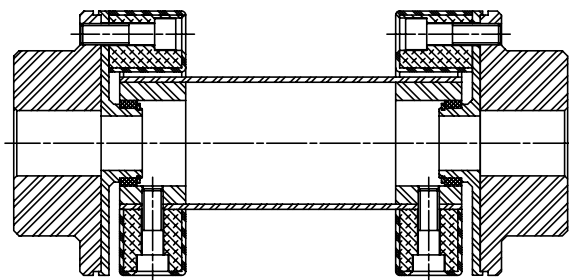

Model 6B

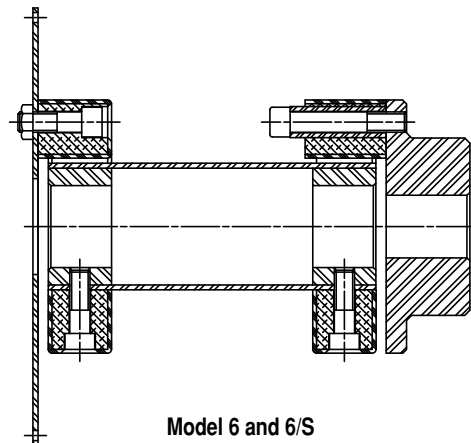

Model 6 and 6/S



LF Series Performance Data

Size	Element Material	Nominal Torque T_{KN}		Maximum Torque T_{Kmax}		Max Speed N_{max} RPM	Allowable Continuous Vibratory Trq T_{KW}		Dynamic Torsional Stiffness C_{Tdyn}							
		in-lb	Nm	in-lb	Nm		in-lb	Nm	Rubber 60 Shore (Standard)		Rubber 50 Shore (Optional)		Hytrel ^{®1}		Zytel [®]	
									in-lb/rad	Nm/rad	in-lb/rad	Nm/rad	in-lb/rad	Nm/rad	in-lb/rad	Nm/rad
LF1	HTR	90	10	200	25	10,000	44	5	1,240	140	800	90	—	—	—	—
LF2	HTR	180	20	530	60	8,000	89	10	2,570	290	1,600	180	—	—	—	—
	Zytel [®]	265	30	530	60	10,000	N/A	N/A	—	—	—	—	—	—	55,150	6 230
LF4	HTR	440	50	1,100	125	7,000	180	20	7,500	850	4,870	550	—	—	—	—
LF8	HTR	885	100	2,480	280	6,500	355	40	13,300	1 500	7,970	900	—	—	—	—
	Zytel [®]	1,060	120	2,480	280	7,000	N/A	N/A	—	—	—	—	—	—	414,370	46 820
LF12	HTR	1,240	140	3,190	360	6,500	440	50	38,900	4 400	23,900	2 700	—	—	—	—
LF16	HTR	1,770	200	4,960	560	6,000	710	80	30,100	3 400	17,700	2 000	—	—	—	—
	Hytrel [®]	1,770	200	4,960	560	5,500	N/A	N/A	—	—	—	—	320,000	36 000	—	—
	Zytel [®]	2,120	240	4,960	560	6,000	N/A	N/A	—	—	—	—	—	—	654,800	74 000
LF22	HTR	2,430	275	6,640	750	6,000	885	100	79,600	9 000	54,000	6 100	—	—	—	—
LF25	HTR	2,790	315	7,740	875	5,000	1,100	125	39,800	4 500	4,800	2 800	—	—	—	—
LF28	HTR	3,700	420	10,600	1 200	5,000	1,330	150	106,200	12 000	66,400	7 500	—	—	—	—
LF30	HTR	4,400	500	12,400	1 400	4,000	1,770	200	69,000	7 800	42,500	4 800	—	—	—	—
	Hytrel [®]	4,400	500	12,400	1 400	4,000	N/A	N/A	—	—	—	—	780,000	88 000	—	—
LF50	HTR	6,200	700	18,600	2 100	4,000	2,650	300	168,100	19 000	106,200	12 000	—	—	—	—
	Hytrel [®]	7,100	800	17,700	2 000	4,000	N/A	N/A	—	—	—	—	2,300,000	262 000	—	—
LF80	HTR	7,960	900	18,600	2 100	4,000	2,830	320	221,200	25 000	141,600	16 000	—	—	—	—
LF90	HTR	9,700	1 100	27,900	3 150	3,600	3,980	450	141,600	16 000	92,900	10 500	—	—	—	—
LF140	HTR	15,000	1 700	43,400	4 900	3,600	6,200	700	354,000	40 000	234,500	26 500	—	—	—	—
LF250	HTR	26,500	3 000	77,400	8 750	3,000	11,000	1 250	592,900	67 000	380,500	43 000	—	—	—	—

Notes: ■ 1 indicates: For Hytrel, dynamic torsional stiffness values are non-linear with respect to torque. Value given is for 100% of nominal torque.
 ■ N/A indicates: Not Applicable.
 ■ HTR is High Temperature Rubber.

LF Series Performance Data

Continued

Size	Element Material	Max Allowable Misalignment*								Wind Up		Static Stiffness					
		Angular ΔK_w Degrees	Parallel ΔK_r in mm		Axial (End Float) Standard ΔK_s in mm		Axial (End Float) S-Style** in mm		(angle of twist)		Axial C_s		Radial C_r		Angular C_w		
			Nominal Torque Degrees	at Maximum Torque Degrees	at Nominal Torque Degrees	at Maximum Torque Degrees	lb/in	N/mm	lb/in	N/mm	in-lb/deg	Nm/deg					
													at Nominal Torque Degrees	at Maximum Torque Degrees			
LF1	HTR	3.00	0.060	1.5	+/-0.08	+/-2	+0.18 / -0.08	+4.6 / -2	6	17.0	220	38	860	150	2.66	0.3	
LF2	HTR	3.00	0.060	1.5	+/-0.12	+/-3	+0.12 / -0.12	+3 / -3	6	17.0	130	22	860	150	2.66	0.3	
	Zytel®	1.00	0.004	0.1	+/-0.02	+/-0.5	+0.12 / -0.02	+3 / -0.5	—	—	—	—	—	—	—	—	
LF4	HTR	3.00	0.060	1.5	+/-0.12	+/-3	+0.17 / -0.12	+4.3 / -3	5	12.0	430	75	2,860	500	21.30	2.4	
LF8	HTR	3.00	0.080	2.0	+/-0.16	+/-4	+0.20 / -0.16	+5 / -4	5	14.0	430	75	2,860	500	31.90	3.6	
	Zytel®	1.00	0.004	0.1	+/-0.02	+/-0.5	+0.20 / -0.02	+5 / -0.5	—	—	—	—	—	—	—	—	
LF12	HTR	2.00	0.080	2.0	+/-0.12	+/-3	+0.20 / -0.16	+5 / -4	3	7.5	1,430	250	5,710	1 000	80.00	9.0	
LF16	HTR	3.00	0.080	2.0	+/-0.20	+/-5	+0.23 / -0.20	+5.8 / -5	5	14.0	570	100	2,860	500	44.00	5.0	
	Hytrel®	0.25	0.000	0.0	+0.12 / -0.08	+3 / -2	N/A	N/A	—	—	—	—	—	—	—	—	
	Zytel®	1.00	0.004	0.1	+/-0.02	+/-0.5	+0.23 / -0.02	+5.8 / -0.5	—	—	—	—	—	—	—	—	
LF22	HTR	2.00	0.080	2.0	+/-0.12	+/-3	+0.23 / -0.20	+5.8 / -5	3	7.5	2,860	500	7,420	1 300	106.00	12.0	
LF25	HTR	3.00	0.080	2.0	+/-0.20	+/-5	+0.26 / -0.20	+6.6 / -5	5	14.0	800	140	3,400	600	62.00	7.0	
LF28	HTR	2.00	0.080	2.0	+/-0.12	+/-3	+0.26 / -0.20	+6.6 / -5	3	7.5	3,140	550	8,000	1 400	150.00	17.0	
LF30	HTR	3.00	0.080	2.0	+/-0.20	+/-5	+0.26 / -0.20	+6.6 / -5	5	14.0	1,090	190	4,280	750	80.00	9.0	
	Hytrel®	0.25	0.000	0.0	+0.12 / -0.08	+3 / -2	N/A	N/A	—	—	—	—	—	—	—	—	
LF50	HTR	3.00	0.080	2.0	+/-0.20	+/-5	+0.26 / -0.20	+6.6 / -5	3	7.5	3,700	650	12,600	2 200	230.00	26.0	
	Hytrel®	0.25	0.000	0.0	+0.12 / -0.08	+3 / -2	N/A	N/A	—	—	—	—	—	—	—	—	
LF80	HTR	2.00	0.060	1.5	+/-0.20	+/-5	+0.26 / -0.12	+6.6 / -3	3	7.5	4,850	850	16,600	2 900	300.00	34.0	
LF90	HTR	3.00	0.080	2.0	+/-0.20	+/-5	+0.34 / -0.20	+8.6 / -5	5	14.0	1,260	220	5,700	1 000	150.00	17.0	
LF140	HTR	2.00	0.080	2.0	+/-0.20	+/-5	+0.34 / -0.20	+8.6 / -5	3	7.5	3,700	650	13,100	2 300	336.00	38.0	
LF250	HTR	2.00	0.080	2.0	+/-0.20	+/-5	+0.40 / -0.20	+10 / -5	3	7.5	6,570	1 150	23,400	4 100	600.00	68.0	

- Notes:
- * indicates: Angular and parallel misalignment values are dependent on speed, and for rubber elements, should be adjusted according to figure 4 on page T-9. Hytrel® elements are only for applications where the driven component is piloted to the driver for SAE and DIN established alignments (i.e. Hydraulic pump flange-mounted to engine flywheel housing).
 - ** indicates: The "S-Style" design is not constrained axially and allows the hubs to move apart without creating axial force on the connected equipment.
 - N/A indicates: Not Applicable.
 - Hytrel® elements are only for applications where the driven component is piloted to the driver for essentially perfect alignment (hydraulic pump flange-mounted to engine housing).
 - Special length S-Style fastener sleeves can further increase the allowable end float.
 - HTR is High Temperature Rubber.

Torsional

LF Series – Base Element and Model 1 Dimensional Data

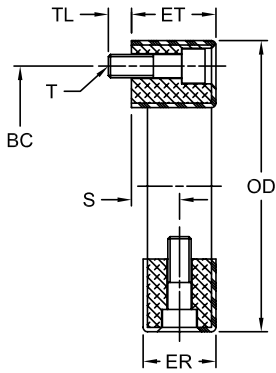

Base Element (HTR)

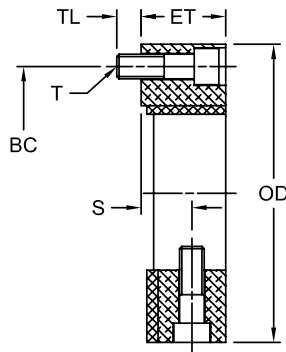

Base Element (Hytrel®)

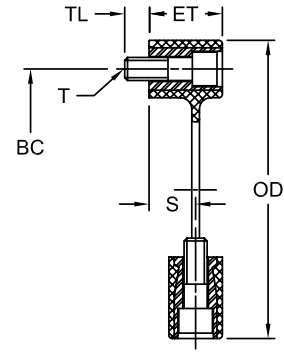

Base Element (Zytel®)

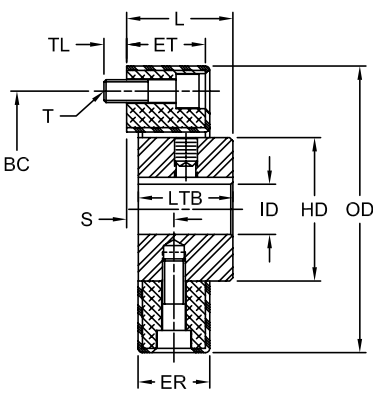

Model 1 (HTR)

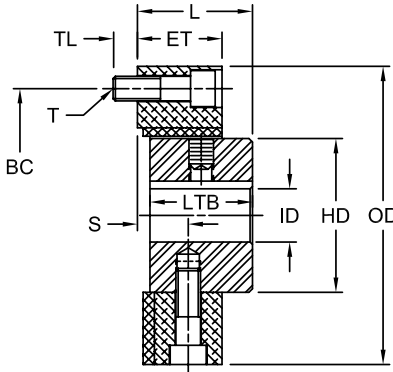

Model 1 (Hytrel®)

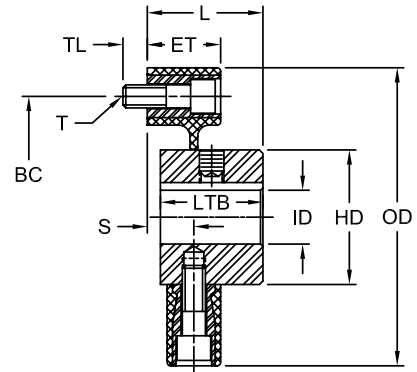

Model 1 (Zytel®)

LF Series Base Element and Model 1 Dimensional Data

Size	ID 1 (Cylindrical Hub)		ID 2 (Flange Hub)				OD			FOD	ET			OAL		L																
	Min Bore	Max Bore	Min Bore	Max Bore	Min Bore	Max Bore	HTR	Hytrel®	Zytel®		HTR	Hytrel®	Zytel®	HTR	Hytrel®	Zytel®																
	in	mm	in	mm	in	mm	in	mm	in	mm	in	mm	in	mm	in	mm	in	mm	in	mm												
LF1	0.31	8	0.63	19	0.31	8	0.88	25	2.20	56	—	—	—	—	—	—	1.97	50.0	1.02	26	—	—	—	—								
LF2	0.44	10	0.88	26	0.50	12	1.38	38	3.35	85	—	—	3.48	32	3.35	85	0.94	24	—	—	—	—	0.94	32	2.36	60.0	1.26	32	—	—	1.26	32.0
LF4	0.47	12	1.00	30	0.63	15	1.75	45	3.94	100	—	—	—	—	3.94	100	1.10	28	—	—	—	—	—	—	2.52	64.0	1.34	34	—	—	—	—
LF8	0.50	12	1.38	38	0.75	18	2.00	55	4.72	120	—	—	—	—	4.72	120	1.26	32	—	—	—	—	1.18	45	3.46	88.0	1.81	46	—	—	1.77	45.0
LF12	0.50	12	1.38	38	0.75	18	2.00	55	4.80	122	—	—	—	—	4.72	120	1.26	32	—	—	—	—	—	—	3.46	88.0	1.81	46	—	—	—	—
LF16	0.63	15	1.63	48	0.81	20	2.63	70	5.91	150	6.10	155	6.10	53	5.91	150	1.65	42	1.69	58	1.38	53	4.17	106.0	2.20	56	2.28	58	2.08	53.0	—	—
LF22	0.63	15	1.63	48	0.81	20	2.63	70	5.91	150	—	—	—	—	5.91	150	1.65	42	—	—	—	—	—	—	4.17	106.0	2.20	56	—	—	—	—
LF25	0.63	15	2.13	55	0.81	20	2.75	85	6.69	170	7.17	182	—	—	6.69	170	1.81	46	1.85	62	—	—	—	—	4.57	116.0	2.40	61	2.44	62	—	—
LF28	0.63	15	2.13	55	0.81	20	2.75	85	6.69	170	—	—	—	—	6.69	170	1.81	46	—	—	—	—	—	—	4.57	116.0	2.40	61	—	—	—	—
LF30	0.81	20	2.44	65	1.00	25	3.75	100	7.87	200	8.07	205	—	—	7.87	200	2.28	56	2.28	76	—	—	—	—	5.51	140.0	2.91	74	2.99	76	—	—
LF50	0.81	20	2.44	65	1.00	25	3.75	100	7.87	200	8.07	205	—	—	7.87	200	2.28	56	2.28	76	—	—	—	—	5.51	140.0	2.91	74	2.99	76	—	—
LF80	0.81	20	2.44	65	1.00	25	3.75	100	8.07	205	—	—	—	—	7.87	200	2.56	65	—	—	—	—	—	—	5.51	141.5	2.97	76	—	—	—	—
LF90	1.19	30	3.35	85	1.19	30	4.25	110	10.24	260	—	—	—	—	10.24	260	2.76	70	—	—	—	—	—	—	6.61	168.0	3.46	88	—	—	—	—
LF140	1.19	30	3.35	85	1.19	30	4.25	110	10.24	260	—	—	—	—	10.24	260	2.76	70	—	—	—	—	—	—	6.61	168.0	3.46	88	—	—	—	—
LF250	1.63	40	4.25	105	1.63	40	5.00	130	13.38	340	—	—	—	—	13.38	340	3.34	84	—	—	—	—	—	—	8.18	208.0	4.25	108	—	—	—	—

Note: ■ HTR is High Temperature Rubber.

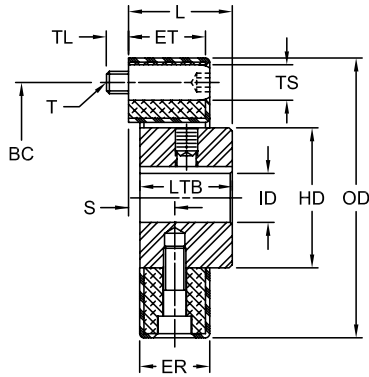

Model 1S (HTR)

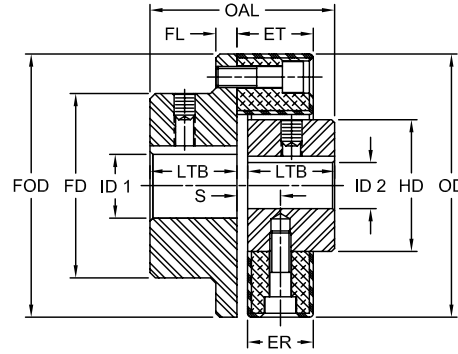

Model 2 (HTR)

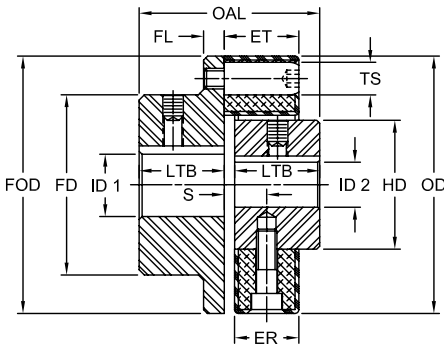

Model 2/S (HTR)

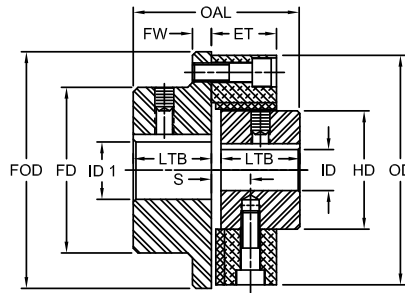

Model 2 (Hytre®)

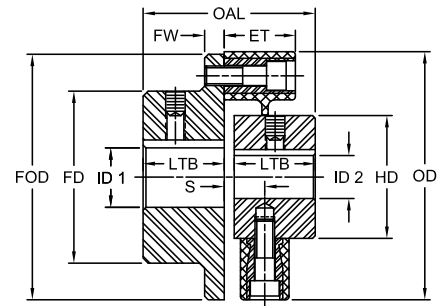

Model 2 (Zytel®)

LF Series Base Element and Model 1 Dimensional Data

Continued

Size	LTB		HD		FD		FW		BE		S* (+/-0.11) (+/-3)		ER**		R		BC		Axial Hole and Division	T	TS		TL			
	in	mm	in	mm	in	mm	in	mm	in	mm	in	mm	in	mm	in	mm	in	mm			in	mm		in	mm	
LF1	0.94	24	1.18	30	1.44	36	0.27	7	0.08	2	—	—	0.87	22	0.43	11.0	1.73	44	2@180°	M6	0.39	10	—	—	0.28	7
LF2	1.10	28	1.57	40	2.17	55	0.31	8	0.16	4	—	—	0.79	20	0.39	10.0	2.68	68	2@180°	M8	0.55	14	0.59	15	0.31	8
LF4	1.18	30	1.77	45	2.56	65	0.31	8	0.16	4	—	—	0.94	24	0.47	12.0	3.15	80	3@120°	M8	0.55	14	—	—	0.31	8
LF8	1.65	42	2.36	60	3.15	80	0.39	10	0.16	4	—	—	1.10	28	0.55	14.0	3.94	100	3@120°	M10	0.67	17	0.75	19	0.39	10
LF12	1.65	42	2.36	60	3.15	80	0.39	10	0.16	4	—	—	1.10	28	0.55	14.0	3.94	100	4@ 90°	M11	0.67	17	—	—	0.39	10
LF16	1.97	50	2.76	70	3.94	100	0.47	12	0.24	6	1.02	26	1.42	36	0.71	18.0	4.92	125	3@120°	M12	0.75	19	0.86	22	0.47	12
LF22	1.97	50	2.76	70	3.94	100	0.47	12	0.24	6	—	—	1.42	36	0.71	18.0	4.92	125	4@ 90°	M12	0.75	19	—	—	0.47	12
LF25	2.16	55	3.35	85	4.53	115	0.55	14	0.24	6	1.06	27	1.57	40	0.79	20.0	5.51	140	3@120°	M14	0.86	22	—	—	0.55	14
LF28	2.16	55	3.35	85	4.53	115	0.55	14	0.24	6	—	—	1.57	40	0.79	20.0	5.51	140	4@ 90°	M14	0.86	22	—	—	0.55	14
LF30	2.60	66	3.94	100	5.51	140	0.63	16	0.31	8	1.38	35	1.97	50	0.98	25.0	6.50	165	3@120°	M16	0.98	25	—	—	0.63	16
LF50	2.60	66	3.94	100	5.51	140	0.63	16	0.31	8	1.38	35	1.99	50	0.98	25.0	6.50	165	4@ 90°	M16	0.98	25	—	—	0.63	16
LF80	2.60	66	3.94	100	5.51	140	0.63	16	0.31	8	—	—	2.40	61	1.20	30.5	6.50	165	4@ 90°	M16	0.98	25	—	—	0.63	16
LF90	3.15	80	4.92	125	6.30	160	0.75	19	0.31	8	—	—	2.44	62	1.22	31.0	8.46	215	3@120°	M20	1.26	32	—	—	0.79	20
LF140	3.15	80	4.92	125	6.30	160	0.75	19	0.31	8	—	—	2.44	62	1.22	31.0	8.46	215	4@ 90°	M20	1.26	32	—	—	0.79	20
LF250	3.94	100	6.30	160	7.68	195	0.75	19	0.31	8	—	—	3.03	77	0.89	22.5	11.02	280	4@ 90°	M20	1.26	32	—	—	0.79	20

- Notes: ■ * indicates: Dimension S for Hytre® only.
 ■ ** indicates: Dimension ER for HTR (rubber) only.
 ■ Dimensions for basic Models 1, 2, 3 and 6.
 ■ HTR is High Temperature Rubber.

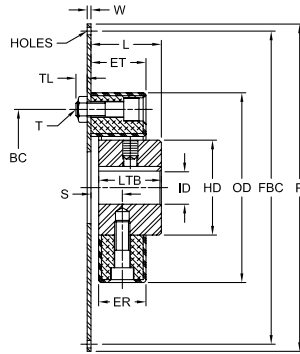

Model 3 (HTR)

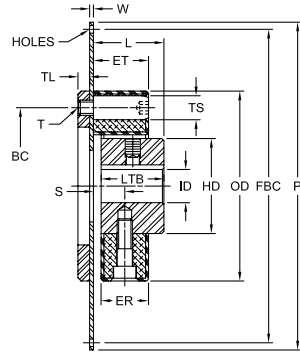

Model 3/S (HTR)

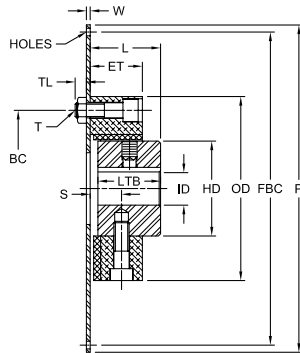

Model 3 (Hytrel®)

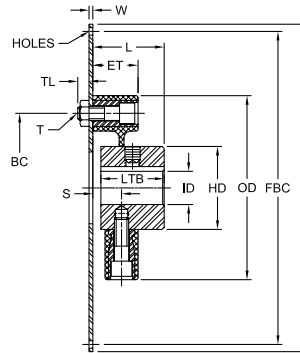

Model 3 and 3/S (Zytel®)

LF Series Flywheel Models 3 and 3/S Dimensional Data

Size	ID				OD						ET						TL		L						W	
	Min		Max		HTR		Hytrel®		Zytel®		HTR		Hytrel®		Zytel®		in mm		HTR		Hytrel®		Zytel®		in mm	
	in	mm	in	mm	in	mm	in	mm	in	mm	in	mm	in	mm	in	mm	in	mm	in	mm	in	mm	in	mm	in	mm
LF1	0.31	8	0.63	19	2.20	56	—	—	—	—	0.94	24	—	—	—	—	0.28	7	1.02	26.0	—	—	—	—	—	—
LF2	0.44	10	0.88	26	3.35	85	—	—	3.48	88	0.94	24	—	—	0.94	24	0.31	8	1.26	32.0	—	—	1.26	32	—	—
LF4	0.47	12	1.00	30	3.94	100	—	—	—	—	1.10	28	—	—	—	—	0.31	8	1.34	34.0	—	—	—	—	—	—
LF8	0.50	12	1.38	38	4.72	120	—	—	4.92	125	1.26	32	—	—	1.18	30	0.39	10	1.81	46.0	—	—	1.77	45	0.19	5
LF12	0.50	12	1.38	38	4.80	122	—	—	—	—	1.26	32	—	—	—	—	0.39	10	1.81	46.0	—	—	—	—	0.19	5
LF16	0.63	15	1.63	48	5.91	150	6.10	155	6.10	155	1.65	42	1.69	43	1.38	36	0.47	12	2.20	56.0	2.28	58	2.08	53	0.19	5
LF22	0.63	15	1.63	48	5.91	150	—	—	—	—	1.65	42	—	—	—	—	0.47	12	2.20	56.0	—	—	—	—	0.19	5
LF25	0.63	15	2.13	55	6.69	170	—	—	—	—	1.81	46	—	—	—	—	0.55	14	2.40	61.0	—	—	—	—	0.19	5
LF28	0.63	15	2.13	55	6.69	170	—	—	—	—	1.81	46	—	—	—	—	0.55	14	2.40	61.0	—	—	—	—	0.19	5
LF30	0.81	20	2.44	65	7.87	200	8.07	205	—	—	2.28	58	2.28	58	—	—	0.63	16	2.91	74.0	2.99	76	—	—	0.19	5
LF50	0.81	20	2.44	65	7.87	200	8.07	250	—	—	2.28	58	2.28	58	—	—	0.46	12	2.91	74.0	2.99	76	—	—	0.19	5
LF80	0.81	20	2.44	65	8.07	205	—	—	—	—	2.56	65	—	—	—	—	0.63	16	2.97	75.5	—	—	—	—	0.19	5
LF90	1.19	30	3.35	85	10.24	260	—	—	—	—	2.76	70	—	—	—	—	0.79	20	3.46	88.0	—	—	—	—	0.19	5
LF140	1.19	30	3.35	85	10.24	260	—	—	—	—	2.76	70	—	—	—	—	0.79	20	3.46	88.0	—	—	—	—	0.19	5
LF250	1.63	40	4.25	105	13.38	340	—	—	—	—	3.34	85	—	—	—	—	0.79	20	4.25	108.0	—	—	—	—	0.50	13

Notes: ■ * indicates: Dimension ER for HTR (rubber) only.
 ■ HTR is High Temperature Rubber.

Typical Flywheel Housing Combinations

SAE J620D Flywheel Size	LF Series Size	LK Series Size	SAE J617C Flywheel Housing					
			6	5	4	3	2	1
6.5	8 thru 28	100	▲	▲				
7.5	8 thru 28	100	●	●				
8	8 thru 30	100			▲			
10	8 thru 140	100, 125			●	▲	▲	
11.5	16 thru 140	100, 125, 150, 150D				●	●	▲
14	28 thru 250	150, UNIV						●
18	250	UNIV						●

Notes: ▲ indicates: Preferred combinations.
● indicates: Optional sizes available.

LF Series Flywheel Models 3/S Dimensional Data

SAE Flywheel Size	P		FBC		Thru Holes Nominal		LF Coupling Size for SAE Flywheel Sizes		
	Pilot Diameter		Bolt Circle Diameter				HTR	Hytrel®	Zytel®
	in	mm	in	mm	Qty	Dia	Model 3 & 3/S	Model 3	Model 3
6.5	8.499	215.90	7.875	200.02	6	0.31	8, 16	8, 16	8, 16
7.5	9.499	241.30	8.750	222.25	8	0.31	8, 16	8, 16	8, 16
8	10.374	263.52	9.625	244.47	6	0.41	16, 25	6, 30	16, 25, 30
10	12.374	314.32	11.625	295.27	8	0.41	25, 30, 50, 90	30, 50	25, 30
11.5	13.874	352.42	13.125	333.37	8	0.41	30, 50, 90, 140, 250	50, 140, 250	30
14	18.374	466.72	17.250	438.15	8	0.53	90, 140, 250	140	N/A
16	20.374	517.50	19.250	488.95	8	0.53	250	250	N/A

Notes: ■ SAE J620 Flywheel dimensions.
■ N/A indicates: Not Applicable.
■ HTR is High Temperature Rubber.

LF Series Flywheel Models 3 and 3/S Dimensional Data

Continued

Size	LTB		BE		S* (±0.11) (+/-3)		ER*		R		HD		BC		Axial Hole and Division	T	TS			
	in	mm	in	mm	in	mm	in	mm	in	mm	in	mm	in	mm			HTR	Zytel®	in	mm
LF1	0.94	24	0.08	2	—	—	0.87	22	0.43	11.0	1.18	30	1.73	44	2@180°	M6	0.39	10	—	—
LF2	1.10	28	0.16	4	—	—	0.79	20	0.39	10.0	1.57	40	2.68	68	2@180°	M8	0.55	14	0.59	15
LF4	1.18	30	0.16	4	—	—	0.94	24	0.47	12.0	1.77	45	3.15	80	3@120°	M8	0.55	14	—	—
LF8	1.65	42	0.16	4	—	—	1.10	28	0.55	14.0	2.36	60	3.94	100	3@120°	M10	0.67	17	0.75	19
LF12	1.65	42	0.16	4	—	—	1.10	28	0.55	14.0	2.36	60	3.94	100	4@ 90°	M11	0.67	17	—	—
LF16	1.97	50	0.24	6	1.02	26	1.42	36	0.71	18.0	2.76	70	4.92	125	3@120°	M12	0.75	19	0.86	22
LF22	1.97	50	0.24	6	—	—	1.42	36	0.71	18.0	2.76	70	4.92	125	4@ 90°	M12	0.75	19	—	—
LF25	2.16	55	0.24	6	1.06	27	1.57	40	0.79	20.0	3.35	85	5.51	140	3@120°	M14	0.86	22	—	—
LF28	2.16	55	0.24	6	—	—	1.57	40	0.79	20.0	3.35	85	5.51	140	4@ 90°	M14	0.86	22	—	—
LF30	2.60	66	0.31	8	1.38	35	1.97	50	0.98	25.0	3.94	100	6.50	165	3@120°	M16	0.98	25	—	—
LF50	2.60	66	0.31	8	1.38	35	1.97	50	0.98	25.0	3.94	100	6.50	165	4@ 90°	M16	0.98	25	—	—
LF80	2.60	66	0.16	4	—	—	2.40	61	1.20	30.5	3.94	100	6.50	165	4@ 90°	M16	0.98	25	—	—
LF90	3.15	80	0.31	8	—	—	2.44	62	1.22	31.0	4.92	125	8.46	215	3@120°	M20	1.26	32	—	—
LF140	3.15	80	0.31	8	—	—	2.44	62	1.22	31.0	4.92	125	8.46	215	4@ 90°	M20	1.26	32	—	—
LF250	3.94	100	0.31	8	—	—	3.03	77	0.89 2.15	22.5 54.5	6.30	160	11.02	280	4@ 90°	M20	1.26	32	—	—

Notes: ■ * indicates: Hytrel® only.
■ HTR is High Temperature Rubber.

Model 6 and 6/S (Rubber Base Elements HTR and CR)

This model compensates for considerable axial, radial and angular misalignment. The rubber elements torsionally soft. Lengths are made to customer requirements. S-Style axial mounting screws allow the hubs to have free end float without exerting axial loads on the connected equipment, while allowing for quick assembly.

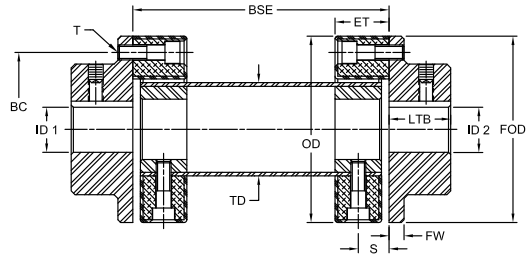

Model 6 (HTR)

Model 6 and 6/S (Zytel® Elements)

Elements made of DuPont's super-tough, corrosion resistant Zytel® are torsionally stiff without backlash, with less than 1° windup. Large spans, equal to all-metal couplings, can be accommodated without internal support bearings when lightweight Zytel® are used. Hubs, hardware and tubes are available in stainless steel or with plating and corrosion resistant coatings. S-Style, axial mounting screws allow for free end-float without harmful reactionary forces.

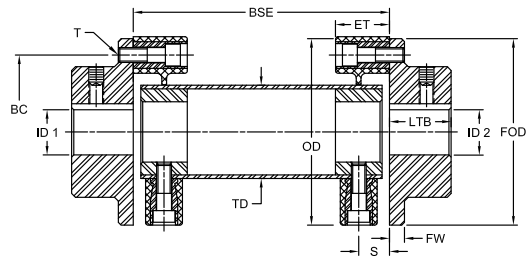

Model 6 (Zytel®)

Model 6B (HTR Elements)

Similar to Model 6 except the center shaft is supported by internal maintenance free bearing material. This allows greater equipment separation and high speeds, as well as high angular misalignment, which can be obtained with rubber elements.

The drawing at the lower left shows one of the many special designs available. A standard flywheel adapter plate (see model 3) is used to couple to a diesel engine flywheel. The flanged hub on the other end is supplied with extra long S-Style connecting screws (Notice the element is reversed from its normal direction). This arrangement permits extensive axial movement (free end float) of the drive package.

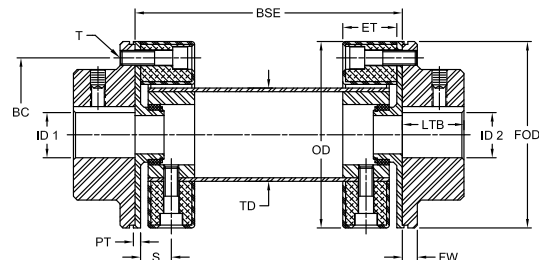

Model 6B (HTR)

One of the many features of the Model 6 is the center floating shaft can be radially removed without displacing the coupled machines. Flexible elements may be pre-assembled to the center segment and then final assembled to the hubs quickly, with little hardware.

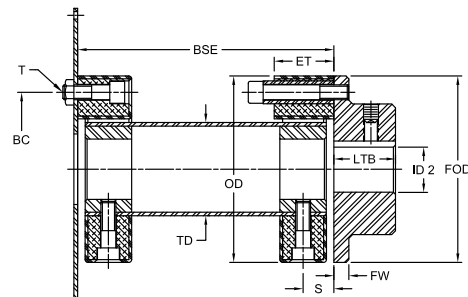

Model 6 and 6/S (HTR)

LF Series Models 6, 6/S and 6/B Dimensional Data

Size	Nominal Torque				ID1 - ID2				OD				BC		Axial Hole and Division
					Min Bore		Max Bore		Element						
	HTR		Zytel®		in	mm	in	mm	HTR		Zytel®		in	mm	
in-lb	Nm	in-lb	Nm	in					mm	in	mm	in			mm
LF1	90	10	—	—	0.31	8	0.88	25	2.20	56	—	—	1.73	44	2@180°
LF2	180	20	265	30	0.50	12	1.38	38	3.35	85	3.48	88	2.68	68	2@180°
LF4	440	50	—	—	0.63	15	1.75	45	3.94	100	—	—	3.15	80	3@120°
LF8	885	100	1,060	120	0.75	18	2.00	55	4.72	120	4.92	125	3.94	100	3@120°
LF12	1,240	140	—	—	0.75	18	2.00	55	4.80	122	—	—	3.94	100	4@ 90°
LF16	1,770	200	2,120	240	0.81	20	2.63	70	5.91	150	6.1	155	4.92	125	3@120°
LF22	2,430	275	—	—	0.81	20	2.63	70	5.91	150	—	—	4.92	125	4@ 90°
LF25	2,790	315	—	—	0.81	20	2.75	85	6.69	170	—	—	5.51	140	3@120°
LF28	3,700	420	—	—	0.81	20	2.75	85	6.69	170	—	—	5.51	140	4@ 90°
LF30	4,425	500	—	—	1.00	25	3.75	100	7.87	200	—	—	6.50	165	3@120°
LF50	6,195	700	—	—	1.00	25	3.75	100	7.87	200	—	—	6.50	165	4@ 90°
LF80	7,960	900	—	—	1.00	25	3.75	100	8.07	205	—	—	6.50	165	4@ 90°
LF90	9,735	1 100	—	—	1.19	30	4.25	110	10.24	260	—	—	8.46	215	3@120°
LF140	15,000	1 700	—	—	1.19	30	4.25	110	10.24	260	—	—	8.46	215	4@ 90°
LF250	26,500	3 000	—	—	1.63	40	5.00	130	13.38	340	—	—	11.02	280	4@ 90°

Note: ■ Refer to Speed and Length Performance Data table (page T-24) for maximum and minimum values.

LF Series Models 6, 6/S and 6/B Dimensional Data

Continued

Size	FOD		LTB		BSE	S		PT		FW		TD		ET			
	Flange		Hub			in	in		in		in		in		HTR		Zytel®
	in	mm	in	mm	mm		mm	mm	mm	mm	mm	mm	mm	mm	in	mm	in
LF1	2.20	56	0.94	24	*	0.51	13	0.20	5	0.28	7	1.18	30	0.94	24	—	—
LF2	3.35	85	1.10	28	*	0.55	14	0.20	5	0.31	8	1.62	40	0.94	24	0.94	24
LF4	3.94	100	1.18	30	*	0.63	16	0.20	5	0.31	8	1.81	45	1.10	28	—	—
LF8	4.72	120	1.65	42	*	0.71	18	0.20	5	0.39	10	2.38	60	1.26	32	1.18	30
LF12	4.80	120	1.65	42	*	0.71	18	0.20	5	0.39	10	2.38	60	1.26	32	—	—
LF16	5.91	150	1.97	50	*	0.94	24	0.20	5	0.47	12	2.75	70	1.65	42	1.38	36
LF22	5.91	150	1.97	50	*	0.94	24	0.20	5	0.47	12	2.75	70	1.65	42	—	—
LF25	6.69	170	2.16	55	*	1.02	26	0.20	5	0.55	14	3.38	85	1.81	46	—	—
LF28	6.69	170	2.16	55	*	1.02	26	0.20	5	0.55	14	3.38	85	1.81	46	—	—
LF30	7.87	200	2.60	66	*	1.30	33	0.20	5	0.63	16	4.00	100	2.28	58	—	—
LF50	7.87	200	2.60	66	*	1.30	33	0.20	5	0.63	16	4.00	100	2.28	58	—	—
LF80	8.07	200	2.60	80	*	1.36	35	0.20	5	0.63	16	4.00	100	2.56	65	—	—
LF90	10.24	260	3.15	80	*	1.54	39	0.20	5	0.75	19	5.00	125	2.76	70	—	—
LF140	10.24	260	3.15	100	*	1.54	39	0.20	5	0.75	19	5.00	125	2.76	70	—	—
LF250	13.38	340	3.94	125	*	1.81	46	0.39	10	0.75	19	6.25	160	3.35	85	—	—

Notes: ■ * indicates: Contact Lovejoy Technical Support when specifying shaft separation.
 ■ Refer to Speed and Length Performance Data table (page T-24) for maximum and minimum values.

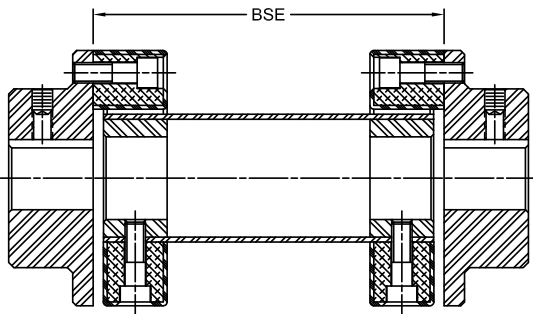

Model 6

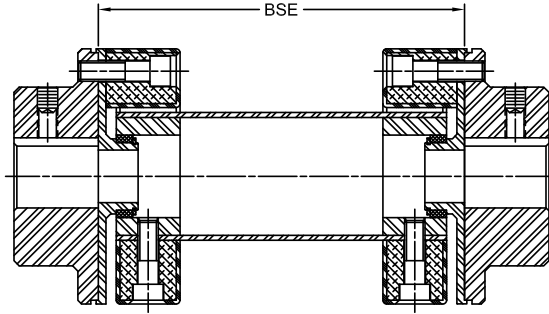

Model 6B

LF Series Models 6 and 6/B Speed and Length Performance Data

Size	Maximum Speed (short length only)			BSE Minimum Length (all versions)		BSE Maximum Length @ 1750 RPM					
	HTR		Zytel® Model 6 RPM			HTR				Zytel® Model 6	
	Model 6 RPM	Model 6B RPM		Model 6 in	Model 6B in	Model 6 mm	Model 6B mm				
LF1	1,500	6,000	—	3.10	79	45	1140	52	1320	—	—
LF2	1,500	6,000	10,000	3.10	79	52	1320	58	1475	58	1475
LF4	2,900	6,000	—	3.61	92	59	1500	62	1575	—	—
LF8	2,900	6,000	7,000	4.17	106	64	1625	72	1830	72	1830
LF12	2,900	6,000	—	4.17	106	64	1625	72	1830	—	—
LF16	2,900	6,000	6,000	5.42	138	65	1650	77	1955	77	1955
LF22	2,900	6,000	—	5.42	138	65	1650	77	1955	—	—
LF25	2,900	5,000	—	5.98	152	58	1475	84	2130	—	—
LF28	2,900	5,000	—	5.98	152	58	1475	84	2130	—	—
LF30	2,900	4,000	—	7.47	190	59	1500	91	2310	—	—
LF50	2,500	4,000	—	7.47	190	83	2100	91	2310	—	—
LF80	2,500	4,000	—	7.47	190	83	2100	91	2310	—	—
LF90	1,500	3,600	—	9.03	230	34	865	99	2515	—	—
LF140	1,500	3,600	—	9.03	230	73	1855	99	2515	—	—
LF250	1,500	3,000	—	10.80	274	86	2185	117	2970	—	—

T



Torsional

LF Series – Models 6 and 6B

Maximum Length and Speed Data

LF Series Model 6 (HTR) Maximum Length “BSE” at Various Speeds - Dimensional Data*

Speed (RPM) →	Maximum Span Length “BSE”																	
	500		600		720		750		900		1000		1200		1500		1800	
Size	in	mm	in	mm	in	mm	in	mm	in	mm	in	mm	in	mm	in	mm	in	mm
LF1	94	2390	86	2185	78	1980	76	1930	69	1750	65	1650	58	1470	51	1300	45	1140
LF2	109	2770	99	2515	89	2260	88	2235	79	2000	74	1880	66	1680	57	1450	52	1320
LF4	116	2950	106	2690	96	2440	94	2390	86	2190	81	2060	73	1850	64	1630	59	1500
LF8	134	3400	121	3070	110	2795	107	3720	97	2460	91	2370	81	2060	70	1780	64	1630
LF12	134	3400	121	3070	110	2795	107	2720	97	2460	91	2370	81	2060	70	1780	64	1630
LF16	144	3660	129	2375	117	2970	114	2900	103	2610	96	2440	85	2160	72	1830	65	1650
LF22	144	3660	129	3275	117	2970	114	2900	103	2610	96	2440	85	2160	72	1930	65	1650
LF25	154	3970	138	3505	123	3125	120	3050	106	2690	98	2490	83	2110	64	1630	58	1470
LF28	154	3970	138	3505	123	3125	120	3050	106	2690	98	2490	83	2110	64	1630	58	1470
LF30	168	4270	151	3835	134	3400	131	3330	115	2920	106	2690	90	2290	68	1730	59	1500
LF50	173	4395	157	3990	143	3630	139	3530	126	3200	119	3020	106	2670	92	2340	83	2100
LF80	173	4395	157	3990	143	3630	139	3530	126	3200	119	3020	106	2690	92	2340	83	2100
LF90	177	4495	155	3940	134	3400	130	3300	107	2720	94	2390	69	1750	38	965	34	860
LF140	187	4750	169	4290	151	3835	147	3730	130	3300	121	3070	104	2640	83	2100	73	1860
LF250	211	5360	190	4830	171	4340	167	4240	148	3760	137	3480	118	3000	94	2390	86	2190

Notes: ■ * indicates: Longer span length for given speed is possible with model 6B.
 ■ Please consult Lovejoy Technical Support for maximum span for higher speeds.

LF Series Model 6 (Zytrel®) Maximum Length “BSE” at Various Speeds - Dimensional Data*

Speed (RPM) →	LF Series Model 6 with (Zytrel®) Maximum Span Length “BSE”																	
	500		600		720		750		900		1000		1200		1500		1800	
Size	in	mm	in	mm	in	mm	in	mm	in	mm	in	mm	in	mm	in	mm	in	mm
LF2X	110	2794	101	2565	92	2337	90	2286	82	2083	82	2083	71	1803	64	1626	58	1473
LF8X	136	3454	124	3150	113	2870	110	2794	101	2565	101	2565	87	2210	78	1981	72	1829
LF16X	147	3734	134	3404	122	3099	120	3048	109	2769	109	2769	94	2388	84	2134	72	1829

Note: ■ * indicates: Maximum span length is based on tube deflection and a critical speed 1.5 times above operating speed.

LF Series Weight and Mass Moment of Inertia for Couplings with HTR Elements

Size	Weights*										Inertia**									
	Base Element		Model 1		Model 1/S		Model 2		Model 2/S		Base Element		Model 1		Model 1/S		Model 2		Model 2/S	
	lb	kg	lb	kg	lb	kg	lb	kg	lb	kg	lb-in ²	kg-cm ²	lb-in ²	kg-cm ²	lb-in ²	kg-cm ²	lb-in ²	kg-cm ²	lb-in ²	kg-cm ²
LF1	0.13	0.06	0.46	0.21	0.53	0.24	1.04	0.47	1.08	0.49	0.12	0.35	0.26	0.75	0.29	0.86	0.55	1.60	0.58	1.70
LF2	0.33	0.15	1.01	0.46	1.08	0.49	2.34	1.06	2.40	1.09	0.43	1.25	0.85	2.5	1.13	3.3	2.5	7.3	2.8	8.1
LF4	0.46	0.21	2.89	1.31	1.54	0.70	5.09	2.31	3.75	1.70	1.13	3.30	1.71	5.0	2.22	6.5	3.9	11.3	4.4	12.8
LF8	0.71	0.32	2.98	1.35	3.17	1.44	7.61	3.45	7.80	3.54	2.39	7.0	5.13	15.0	6.36	18.6	14.0	41.0	15.2	44.6
LF12	0.77	0.35	3.20	1.45	3.44	1.56	7.83	3.55	8.07	3.66	2.87	8.4	6.22	18.2	6.83	20.0	15.1	44.2	15.8	46.1
LF16	1.43	0.65	5.03	2.28	5.14	2.33	13.58	6.16	13.69	6.21	8.00	23.4	14.5	42.5	16.8	49.1	40.6	118.8	42.9	125.4
LF22	1.54	0.70	5.56	2.52	5.78	2.62	14.15	6.42	14.59	6.62	9.09	26.6	17.2	50.4	24.0	70.2	43.2	126.5	50.0	146.3
LF25	1.85	0.84	7.91	3.59	8.31	3.77	20.53	9.31	20.92	9.49	17.2	50.2	31.0	90.7	35.1	102.7	73.5	215.0	77.6	227.0
LF28	2.09	0.95	8.36	3.79	8.93	4.05	20.97	9.51	21.52	9.76	19.0	55.6	35.0	102.4	38.7	113.2	84.7	247.8	88.3	258.5
LF30	3.15	1.43	12.48	5.66	13.27	6.02	33.53	15.21	34.33	15.57	34.9	102.0	68.3	200.0	75.3	220.4	186.4	545.5	193.4	565.9
LF50	3.53	1.60	13.32	6.04	14.33	6.50	34.39	15.60	35.38	16.05	35.5	104.0	70.1	205.0	86.6	253.4	188.1	550.5	204.7	598.9
LF80	4.63	2.10	15.10	6.85	15.98	7.25	36.60	16.60	37.48	17.00	45.0	131.8	82.1	240.3	90.2	263.9	200.1	585.5	208.1	609.1
LF90	7.28	3.30	25.46	11.55	26.96	12.23	63.21	28.67	64.71	29.35	153.8	450.0	224.7	657.5	259.4	759.2	557.0	1630.1	591.8	1731.8
LF140	8.05	3.65	27.18	12.33	29.15	13.22	64.93	29.45	66.93	30.36	195.5	573.0	263.1	770.0	298.3	873.0	595.5	1742.6	630.7	1845.6
LF250	15.65	7.10	41.84	18.98	44.11	20.01	97.93	44.42	100.18	45.44	599.4	1754.0	821.5	2404.0	864.2	2529.0	1798.8	5264.0	18471.5	5389.0

- Notes:
- * To obtain Weight of Model-3:
 1. Select weight of flywheel plate (from chart below labeled SAE Flywheel Adapter Plates)
 2. Select weight of Model 1 or 1/S coupling (from chart above)
 3. Add flywheel plate and coupling weight together
 - ** To obtain Inertia of Model-3:
 1. Select inertia of flywheel plate (from chart below labeled SAE Flywheel Adapter Plates)
 2. Select inertia of Model 1 or 1/S coupling (from chart above)
 3. Add flywheel plate and coupling inertia together

LF Series Weight and Mass Moment of Inertia for Couplings with Hytrel® Elements

Size	Weight						Inertia					
	Model 1		Model 2		Hytrel®		Model 1		Model 2		Hytrel®	
	lb	kg	lb	kg	lb	kg	lb-in ²	kg-cm ²	lb-in ²	kg-cm ²	lb-in ²	kg-cm ²
LF16	5.07	2.30	10.58	4.80	-	-	17.7	206.6	43.7	512.0	-	-
LF30	11.46	5.20	29.32	13.30	14.33	6.50	68.4	800.7	186.5	2183.2	150.3	1759.4 (SAE10)
LF50	12.35	5.60	30.20	13.70	15.43	7.00	80.5	942.3	198.7	2326.0	197.4	2310.8 (SAE 11.5)

**SAE Flywheel Adapter Plates
(3/16" thick)**

SAE Flywheel Size (J620)	Weight		Inertia	
	lb	kg	lb-in ²	kg-cm ²
6.5	2.6	1.2	26	76
7.5	3.4	1.5	42	123
8	4.1	1.9	60	176
10	6.0	2.7	122	357
11.5	7.7	3.5	193	565
14	12.8	5.8	589	1724

LF Series Weight and Mass Moment of Inertia for Couplings with Zytel® Elements

Size	Weight						Inertia					
	Base Element		Model 1/1S		Model 2/2S		Base Element		Model 1/1S		Model 2/2S	
	lb	kg	lb	kg	lb	kg	lb-in ²	kg-cm ²	lb-in ²	kg-cm ²	lb-in ²	kg-cm ²
LF2X	0.2	0.1	0.9	0.4	2.2	1.0	17.7	206.6	43.7	512.0	-	-
LF8X	0.6	0.3	3.3	1.5	7.7	3.5	68.4	800.7	186.5	2183.2	150.3	1759.4 (SAE10)
LF16X	1.0	0.5	4.6	2.1	13.1	5.9	80.5	942.3	198.7	2326.0	197.4	2310.8 (SAE 11.5)

LF Series Floating-Shaft – Models 6 and 6B

The following guidelines cover additional considerations unique to the floating-shaft versions of the LF coupling. Use them together with the selection information for engine applications or general applications found on pages T-6 through T-8.

Step 1: Torque Capacity

Values for normal torque T_{KN} , maximum torque T_{Kmax} , and continuous vibratory torque T_{KW} remain the same and are found in the table of Performance Data on page 16 and 23.

∞ = angular misalignment (degrees)

r = parallel misalignment inches (mm)

and BSE, Y, and BT inches (mm) are from the dimension table.

Step 2: Stiffness Values and Wind-Up

Since 2 torsional rubber elements are used together in series, values from the Performance Data table on page 16 and 17 for dynamic torsional stiffness C_{Tdyn} , static angular stiffness C_w and static axial stiffness C_a , should be multiplied by 1/2. Values for wind-up should be multiplied by 2.

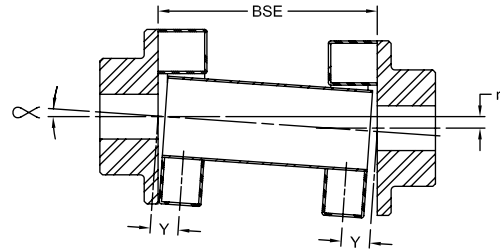

Step 3: Misalignment

Performance Data table values for allowable axial misalignment are doubled for the standard element design. Values for the S-Style version will be the same but can be increased by use of special-length sleeves (consult Lovejoy Technical Support).

The angular and parallel misalignment values are dependent on speed.

Angular misalignment will be equal at both ends and should be kept within the limits given in the Performance Data table. Allowable parallel misalignment is related to the angular misalignment and the distance between shaft ends (BSE). It is calculated by applying one of the following equations:

Model 6: $r = (L - 2Y) \tan(\infty)$

Model 6B: $r = [(L - 2(Y + BT))] \tan(\infty)$

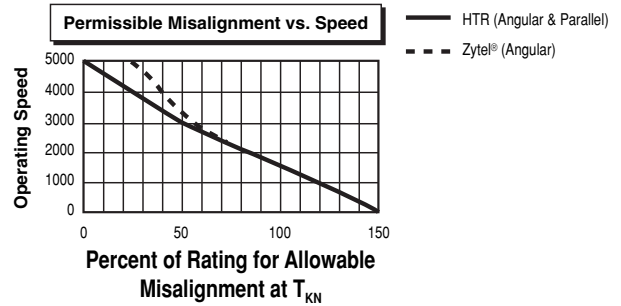

Step 4: Selecting Model 6 or Model 6B (HTR only)

The basic model 6 is suitable for most short or medium length spans (distance between shaft ends). Longer spans and higher speeds will require the bearing-supported floating shaft feature of Model 6B. Regardless of length, some applications will require the Model 6B design based on speed alone. Use the Maximum Speed and Length table to guide your choice or consult Lovejoy Technical Support for assistance.

LVK Series

The LVK Series is designed for direct coupled equipment. The LVK Series coupling is highly torsionally compliant, allowing the engine to drive a large inertia load safely away from damaging torsional resonance or critical speeds. The coupling selection should be verified with a Torsional Vibration Analysis of the system (see page T-10).

Element Features

- 50 & 60 Durometer (Shore A scale) available
- -40° to 194° F temperature range
- Available in SAE J620 6.5 through 14 Flywheel sizes (some metric sizes available upon request)
- Blind assembly, no lubrication
- Material available in HTR and EPDM

Hub Features

- High quality powdered-metal construction
- Splined hubs available with L-LOC clamping system
- Engagement Dogs are slightly crowned to avoid edge pressure due to misalignment
- Available in bore with keyway and spline connections



Typical Applications

Compressors, centrifugal pumps, hydraulic pumps and generator sets.

LVK Series Performance Data

Size	SAE Flywheel Size	Hardness Shore A scale	Power at 2100 RPM		Nominal Torque T_{KN}		Maximum Torque T_{Kmax}		Continuous Vibratory Torque T_w		Dynamic Stiffness C_{Tdyn}	
			HP	kW	in-lbs	Nm	in-lb	Nm	in-lb	Nm	in-lbs/rad	Nm
LVK25	7.5, 8	50	62	46	1,875	212	4,500	508	750	85	12,586	1 422
	10, 11.5	60	90	67	2,700	305	5,750	650	1,080	122	21,658	2 447
LVK30	8, 10	50	98	73	2,945	333	7,089	801	1,180	133	18,201	2 056
	11.5	60	142	106	4,250	480	10,825	1 223	1,700	192	21,970	2 482
LVK35	10, 11.5	50	136	101	4,075	460	9,781	1 105	1,630	184	25,820	2 917
	14	60	193	144	5,800	655	14,500	1 638	2,320	262	31,167	3 521

SAE J620 Flywheel Dimensional Data

Nominal Clutch (flywheel) Size	P1		BC		P2		J		H		G		D		T Tapped Holes	
	in	mm	in	mm	in	mm	in	mm	in	mm	in	mm	in	mm	Qty	Size
6.5	8.500	215.90	7.875	200.02	7.25	184.2	0.38	9.7	0.50	12.7	1.19	30.2	5.00	127.0	6	5/16-18
7.5	9.500	241.30	8.750	222.25	8.12	206.4	0.50	12.7	0.50	12.7	1.19	30.2	—	—	8	5/16-18
8	10.375	263.52	9.625	244.48	8.88	225.6	0.50	12.7	0.50	12.7	2.44	62.0	—	—	6	3/8-16
10	12.375	314.32	11.625	295.28	10.88	276.4	0.50	12.7	0.62	15.7	2.12	53.8	7.75	196.9	8	3/8-16
11.5	13.875	352.42	13.125	333.38	12.38	314.5	0.88	22.4	1.12	28.4	1.56	39.6	8.00	203.2	8	3/8-16
14	18.375	466.72	17.250	438.15	16.12	409.4	0.88	22.4	1.12	28.4	1.00	25.4	8.75	222.2	8	1/2-13
16	20.375	517.52	19.250	488.95	18.12	460.2	0.88	22.4	1.12	28.4	0.62	15.7	10.00	254.0	8	1/2-13
18	22.500	571.50	21.375	542.92	19.62	498.3	1.25	31.8	1.25	31.8	0.62	15.7	—	—	6	5/8-11
21	26.500	673.10	25.250	641.35	23.00	584.2	1.25	31.8	1.25	31.8	0.00	0.0	—	—	12	5/8-11
24	28.875	733.43	27.250	692.15	25.38	644.7	1.25	31.8	1.25	31.8	0.00	0.0	—	—	12	3/4-10

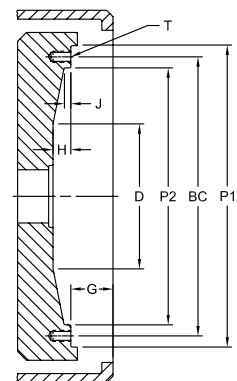

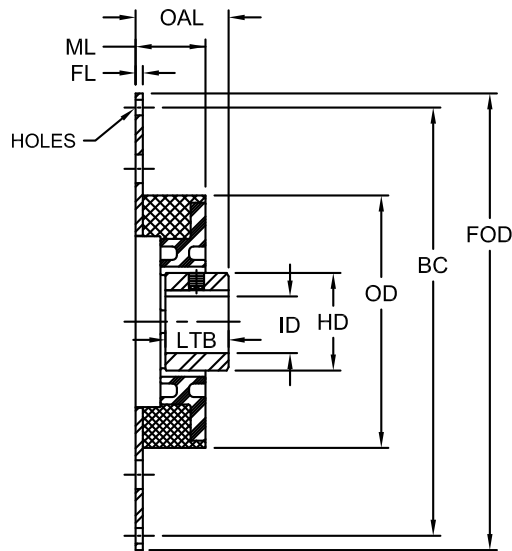

LVK Series - SAE J620 Flywheel Application Dimensional Data

Size	FOD		BC		FL		ML		OAL		OD		HD		LTB*		ID						
	Flange Dimensions						Element Dimensions						Hub Dimensions				Min Bore	Max Bore					
	SAE Flywheel Size	in mm		in mm		Number / Dia of Holes		Flange Thickness	Mounting Length		Element		Hubstar		in mm								
	in	mm	in	mm	in	mm	in	mm	in	mm	in	mm	in	mm	in	mm	in	mm					
LVK25	6.5	8.50	215.9	7.875	200.0	6 x 0.33	6 x 8.5	0.19	4.8	1.83	46.50	-	-	6.90	175.3	2.56	65	-	-	9/16	15	1-9/16	40
	7.5	9.50	241.3	8.750	222.3	8 x 3.30	8 x 8.5					2.17	55					1.26	32				
	8	10.38	263.5	9.625	244.5	6 x 0.41	6 x 10.5					2.68	68					1.89	48				
	10	12.38	314.3	11.625	295.3	6 x 0.41	8 x 10.5					3.00	76					2.20	56				
	11.5	13.88	352.4	13.125	333.4	8 x 0.41	8 x 10.5					-	-					-	-				
LVK30	8	10.38	263.5	9.625	244.5	6 x 0.41	6 x 10.5	0.19	4.8	2.13	54.10	2.72	69	8.10	205.7	3.35	85	1.97	42	13/16	20	2-1/8	55
	10	12.38	314.3	11.625	295.3	8 x 0.41	8 x 10.5					2.95	75					1.89	48				
	11.5	13.88	352.4	13.125	333.4	8 x 0.41	8 x 10.5					-	-					-	-				
LVK35	11.5	13.88	352.4	13.125	333.4	8 x 0.41	8 x 10.5	0.19	4.8	2.20	55.88	2.80	71	8.65	219.7	3.35	85	1.97	42	13/16	20	2-1/8	55
	14	18.38	466.7	17.250	438.2	8 x 0.50	8 x 12.7					3.03	77					1.89	48				

Note: ■ * indicates: Shorter or longer hub lengths available upon request.

LV Series

The LV Series coupling is designed and built for diesel engine driven equipment such as agricultural and offroad equipment using universal joint drive shafts. The LV Series is ideal for universal joint driven equipment applications as well as other arrangements. The LV Series couplings are highly torsionally compliant, allowing the engine to drive a large inertia load safely away from damaging torsional resonance and critical speeds. The coupling selection should be verified with a Torsional Vibration Analysis of the system (see page T-10).

Element Features:

- 50 & 60 Durometer (Shore A scale) available
- - 40° to 194° F temperature range
- Available in SAE J620 6.5 through 14 flywheel sizes and varies in metric sizes
- Blind assembly, no lubrication
- Material available in HTR and EPDM

Optional Hub Features:

- LVC Style hub available for straight and spline bores upon request
- Splined hubs available with L-LOC clamping system

Typical Applications

LVC style is excellent for adapting the LV coupling to applications with generators, reciprocation pumps and compressors, screw compressors, and other equipment driven directly off an SAE flywheel.

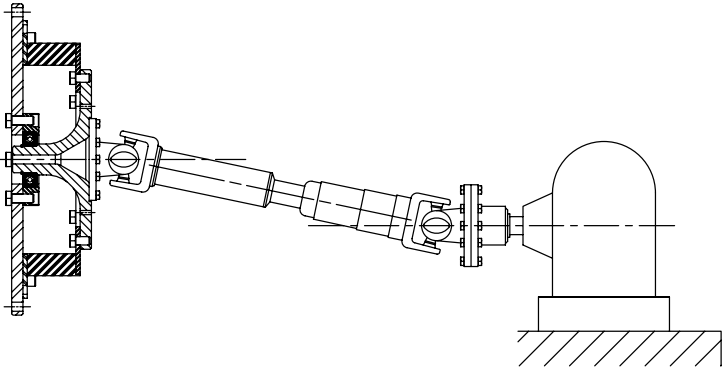

LV Series Performance Data

Size	SAE Flywheel Size	Hardness Shore A scale	Power at 2000 RPM		Nominal Torque T_{KN}		Maximum Torque T_{Kmax}		Continuous Vibratory Torque T_w		Dynamic Torsional Stiffness C_{Tdyn}	
			HP	kW	in-lbs	Nm	in-lb	Nm	in-lb	Nm	in-lb/rad	Nm/rad
LV200	10, 11.5, 14	50	177	132	5,578	630	16,815	1 900	1,395	158	726	82
		60										
LV250	10, 11.5, 14	50	238	178	7,500	847	21,596	2 440	1,875	212	871	98
		60										
LV350	10, 11.5, 14	50	343	256	10,820	1 223	31,860	3 600	2,705	306	1,417	160
		60										

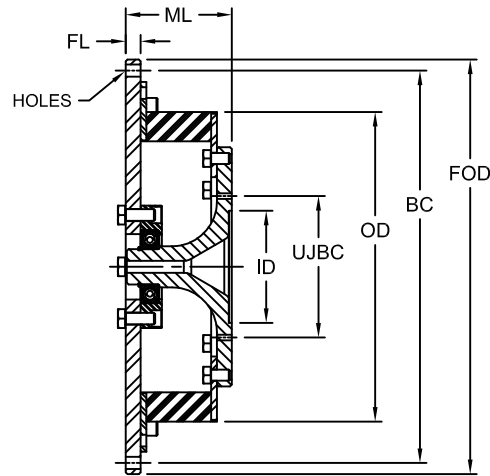

LV Series - SAE J620 Flywheel Application Dimensional Data

Size	Flange Dimensions								U-Joint Adapter Plate									
	SAE Flywheel Size	FOD		BC		Number / Dia of Holes		FL		ML		U-Joint Adapter Model	UJBC		Number of Holes	Thread Size UNF	ID Pilot ID 0.100 Inch	Pilot Depth 2.54 mm
		in	mm	in	mm	in	mm	in	mm	in	mm		in	mm				
LV200	10	12.375	314.3	11.625	295.3	8 x 0.41	8 x 10.5	0.50	12.7	3.55	90.2	—	—	—	—	—	—	
	11.5	13.875	352.4	13.125	333.4	8 x 0.41	8 x 10.5					31	3.125	79.4	4	3/8-24 UNF 2B	2.375	60.4
	14	18.375	466.7	17.250	438.2	8 x 0.50	8 x 12.7					35/41	3.750	95.3	4	7/16-20 UNF 2B	2.750	69.9
LV250	10	12.375	314.3	11.625	295.3	8 x 0.41	8 x 10.5	0.50	12.7	3.55	90.2	35/41	3.750	95.3	4	7/16-20 UNF 2B	2.750	69.9
	11.5	13.875	352.4	13.125	333.4	8 x 0.41	8 x 10.5					48/55	4.750	120.7	4	1/2-20 UNF 2B	3.750	95.3
	14	18.375	466.7	17.250	438.2	8 x 0.50	8 x 12.7					61	6.125	155.6	8	3/8-24 UNF 2B	6.625	168.3
LV350	10	12.375	314.3	11.625	295.3	8 x 0.41	8 x 10.5	0.50	12.7	3.55	90.2	61	6.125	155.6	8	3/8-24 UNF 2B	6.625	168.3
	11.5	13.875	352.4	13.125	333.4	8 x 0.41	8 x 10.5					71	7.250	184.2	8	3/8-24 UNF 2B	7.750	196.9
	14	18.375	466.7	17.250	438.2	8 x 0.50	8 x 12.7					—	—	—	—	—	—	—

LM Series

The LM Series torsional couplings are designed specifically for diesel engine driven equipment. The LM couplings are highly torsionally compliant, allowing the engine to drive a relatively small inertia load safely from damaging torsional resonance over a wide speed range from low idle RPM to full engine speed. This task is accomplished by shifting the critical speeds far enough below the idle speed allowing full use of the entire working speed range of the engine with very few limitations. These engineered couplings affect an attenuated level of stress throughout the whole drive train by reducing vibratory torque to a very low level. The coupling selection should be verified with a Torsional Vibration Analysis of the system.



Materials

Elastomeric Element

- Temperature-resistant natural rubber available in a variety of Shore A scale hardness to suite individual application requirements
- -49° to 200° F operating temperature range
- Silicone element available for high ambient temperatures
- EPDM available for chemical resistant
- -49° to 250° F operating temperature range

Outer Ring

- High-grade cast aluminum alloy

Inner Hub

- Steel with minimum tensile strength of 85,000 psi (600 N/mm²)
- Available in bore with keyway and spline connections
- Taper-Loc spline hubs available
- Splines with L-LOC available

Typical Applications

- Splitter-gear multiple pump drives
- Generator sets (2-bearing)
- Locomotives
- Hydraulic pumps
- Centrifugal pumps
- Compressors

Range of Sizes

- 8 sizes ranging from nominal torques of 2,210 to 33,600 in-lb (250 to 3800 Nm)
- SAE J620 Flywheel sizes available from 6 through 18
- 3 coupling design types



LM Torsional Coupling Design Types

Type SB

Sizes 240 to 2400

The driven inner hub consists of two pieces: the vulcanized steel ring and the inner tapered hub. These two parts are bolted together and the torque is transmitted by the friction force created by the axial bolts, drawing the tapered hub into the mating taper in the element.

This is a long tapered fit, but can easily be disassembled if the coupling has to be removed. The vulcanized steel ring creates a very high inward pressure acting on the inner driven tapered hub. To utilize this pressure, the driven hub is slotted in an axial direction. This compresses the driven hub and driven shaft. This clamping effect can be used equally well on cylindrical shafts with keys or splined shafts.

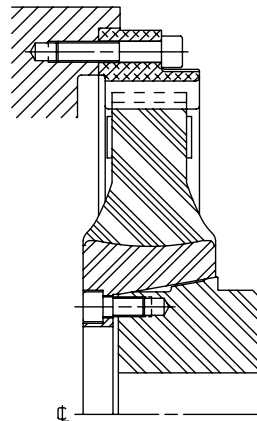

Type SB

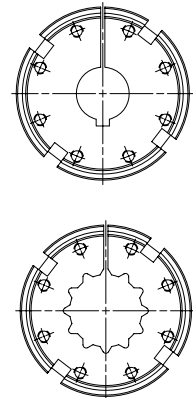

Tapered Locking Hubs

Type SC

Sizes 2800 to 3500

An inner ring made of spheroidal cast iron is vulcanized into the elastomeric element. This flange is bolted to the inner tapered hub. Depending upon the arrangement of the elastomeric element, two different lengths are possible utilizing the same components.

Standard Configuration: SCA
Reversed Element: SCB
 (extended mounting length)

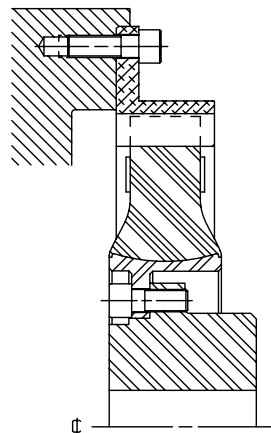

Type SCA

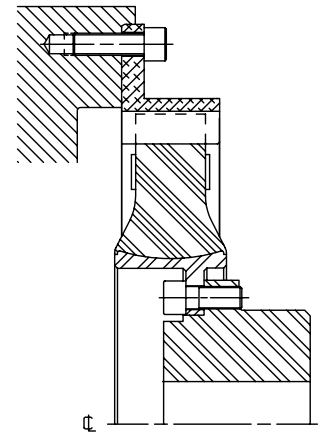

Type SCB

Types SBE and SCE

Special Radial Assembly / Disassembly Types
(Drop-Out Types) All Sizes

The elastomeric element can be changed quickly and easily without disturbing the coupling shaft, provided the flywheel housing does not protrude too much. These versions can be particularly advantageous on larger sizes, especially if the hub is interference fit.

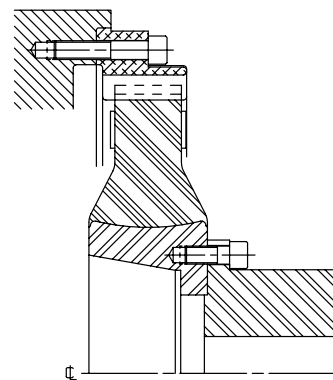

Type SBE

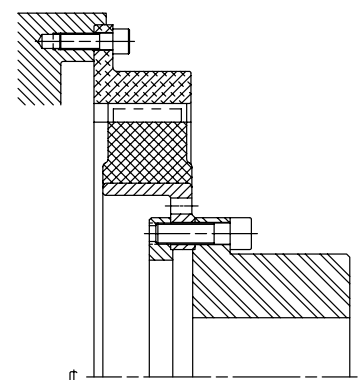

Type SCE

Special Types

In addition to the standard types shown here, many special types have been developed. Please contact Lovejoy Technical Support for more information.

The LK Series coupling is a simple two-piece design consisting of an element and hub. The couplings are designed to be used with engine driven, flange mounted, hydraulic pump systems. The couplings are “torsionally stiff” enabling hydraulic pumps and similar equipment with low mass or inertia to operate below critical speeds. The “torsionally stiff” LK Series coupling raises the critical speed above the operating range providing a system free of harmful torsional vibrations. The LK Series is ideal for hydrostatic drives on construction equipment, cranes, forklifts, excavators, vibratory rollers, tractors, etc. Virtually all engine driven hydraulic systems in the low to mid power range can use the LK Series coupling.

Element Features

- Fiberglass reinforced polyamide construction
- Impact and oil resistant
- -40° to 320° F temperature range
- SAE J620 flywheel sizes 6.5 through 14 and various metric sizes
- Universal element can be mounted to an adapter plate
- Blind assembly, no lubrication

Hub Features

- High quality powdered-metal construction
- Splined hubs available with L-LOC clamping system
- Engagement “dogs” are slightly crowned to avoid edge pressure when slight misalignment occurs
- Available in bore with keyway and spline connections



Typical Applications

Applications where a hydraulic pump is directly connected to the engine such as wheel loaders, hydraulic excavators, vibration rollers, fork lift trucks, concrete cutters, compact loaders, asphalt finishers and mobile cranes.

LK Series Performance Data

Size	SAE Flywheel Size	Nominal Torque T _{KN}		Maximum Torque T _{Kmax}		Maximum Speed RPM	Dynamic Torsional Stiffness								Relative Damping Ψ
							C _{Tdyn}								
							0.25T _{KN}		0.50T _{KN}		0.75T _{KN}		1.00T _{KN}		
in-lb	Nm	in-lb	Nm	in-lb	Nm	in-lb	Nm	in-lb	Nm	in-lb	Nm	in-lb	Nm		
LK80	—	1,080	125	2,880	330	6,000	Consult Lovejoy								0.4
LK100	6.5, 7.5, 8, 10	3,540	400	7,080	800	5,000	490	55	550	62	800	90	1,060	120	
LK125	10, 11.5	7,080	800	14,160	1 600	4,500	1,370	155	1,590	180	2,800	315	4,070	460	
LK150	11.5, 14	10,620	1 200	26,400	3 000	4,000	2,300	260	2,480	280	3,700	420	7,950	900	
LK150D	14	21,240	2 400	58,200	6 000	4,000	4,600	520	4,960	560	7,400	840	15,900	1 800	

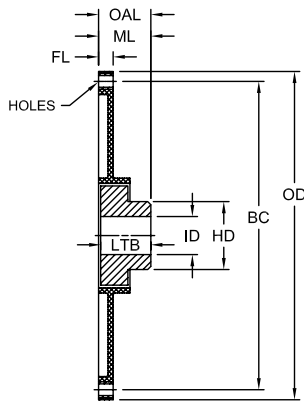

1-Piece Flange

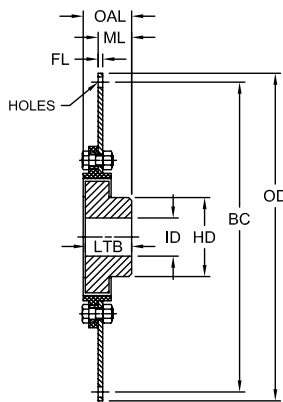

2-Piece Flange
 Universal + Plate

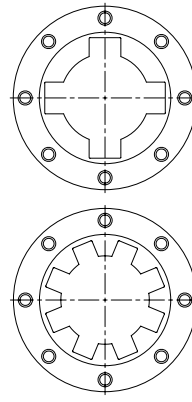

4, 6 and 8 Dog Patterns
 Dependent on Size

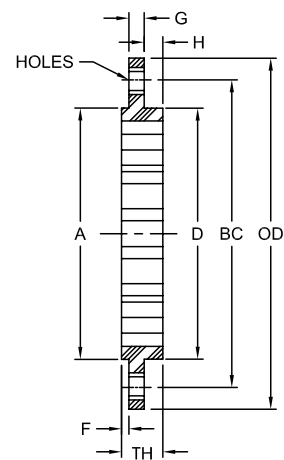

LK Series - SAE J620 Flywheel Application Dimensional Data

Size	Nominal Torque Rating in-lb Nm	ID			OD				BC		FL		HD		LTB*		OAL		ML				
		Min Bore	Max Bore		Flange Dimensions								Hubstar Dimensions				Assembly Dimensions						
		in mm	in mm	in mm	mm	SAE Flywheel Size	Flange Style	in mm		in mm		Number & Dia of Holes		Flange Thickness		in mm		in mm		in mm		Mounting Length	
								in	mm	in	mm	in	mm	in	mm	in	mm	in	mm	in	mm	in	mm
LK100	3,540 400	0.563	15	1.563	40	6.5	1-PIECE	8.500	215.9	7.875	200.0	6 x 0.33	6 x 8.5	0.55	14	2.56	65	—	—	—	—	—	—
						7.5	1-PIECE	9.500	241.3	8.750	222.3	8 x 0.33		0.55	14			1.26	32	1.34	34	0.906 ± 0.118	23+/-3
						8	1-PIECE	10.375	263.5	9.625	244.5	6 x 0.41	6 x 10.5	0.55	14			2.20	56	2.28	58	2.284 ± 0.118	58+/-3
						10	1-PIECE	12.375	314.3	11.625	295.3	8 x 0.41	—	0.55	14			1.89	48	1.97	50	1.969 ± 0.118	50+/-3
LK125	7,080 800	0.813	20	2.125	55	10	1-PIECE	12.375	314.3	11.625	295.3	8 x 0.41	8 x 10.5	0.79	20	3.35	85	1.89	48	1.97	50	1.969 ± 0.118	50+/-3
						11.5	1-PIECE	13.875	352.4	13.125	333.4	8 x 0.41		0.19	20			1.97	42	2.05	46	1.417 ± 0.118	36+/-3
LK150	10,260 1 200	1.000	25	2.750	70	11.5	1-PIECE	13.875	352.4	3.125	333.4	8 x 0.41	8 x 12.7	0.79	20	4.33	110	2.09	53	2.09	53	1.299 ± 0.118	33+/-1
						14	2-PIECE	18.375	466.7	17.250	438.2	8 x 0.50		0.19	5			2.09	53	2.09	53	0.984 ± 0.118	25+/-1
LK150D	21,240 2 400	1.188	30	2.750	70	14	**	18.375	466.7	17.250	438.2	8 x 0.50	8 x 12.7	0.19	5	4.33	110	2.05	52	2.13	54	0.984 ± 0.118	25+/-1

Notes: ■ * indicates: Other shorter or longer hub lengths available for special requirements.
 ■ ** indicates: LK 150D uses 2 Zytel® elements in parallel with 1 steel plate.

LK Series Universal Elements Dimensional Data

Size	G		H		TH		E		OD		BC		D		A		Number of Holes	S Hole Diameter	
	in	mm	in	mm	in	mm	in	mm	in	mm	in	mm	in	mm	in	mm		in	mm
LK80-6-106	0.55	14.0	0.38	9.7	0.19	4.8	1.12	2.84	5.910	150	5.118	130	3.600	91.4	4.173	106	5	0.33	8.4
LK80-6-135	0.39	9.9	0.61	15.5	*	*	1.00	25.4	5.315	135	3.937	100	3.629	92.2	5.315	135	3	0.41	10.4
LK100-165	0.39	10.0	0.79	20.0	0.16	4.0	1.34	34.0	6.850	174	5.591	142	4.921	125.0	4.921	125	3	0.49	12.5
LK100-072	0.39	10.0	0.79	20.0	0.16	4.0	1.34	34.0	7.870	200	6.496	165	4.330	110.0	2.835	72	3	0.65	16.5
LK125-195	0.39	10.0	0.55	14.0	0.24	6.0	1.18	30.0	7.680	195	6.496	165	5.315	135.0	5.135	135	6	0.49	12.5
LK150-230	0.39	10.0	0.47	12.0	0.20	5.0	1.06	27.0	9.060	230	7.874	200	6.500	165.0	6.496	165	8	0.49	12.5

Notes: ■ * indicates: LK80-6-135 pilots on the O.D.
 ■ Dimensions for universal elements (for non-SAE flywheels, etc.).

Spacer Rings

Spacer rings are available for all SAE bell housing sizes (1,2,3,4,5,6). The rings provide additional space standoff from the engine flywheel housing and the pump mounting spacer plate. The spacer ring will provide the necessary area between the flywheel and the pump for the proper torsional coupling. When ordering spacer rings, specify the SAE bell housing size and required thickness.

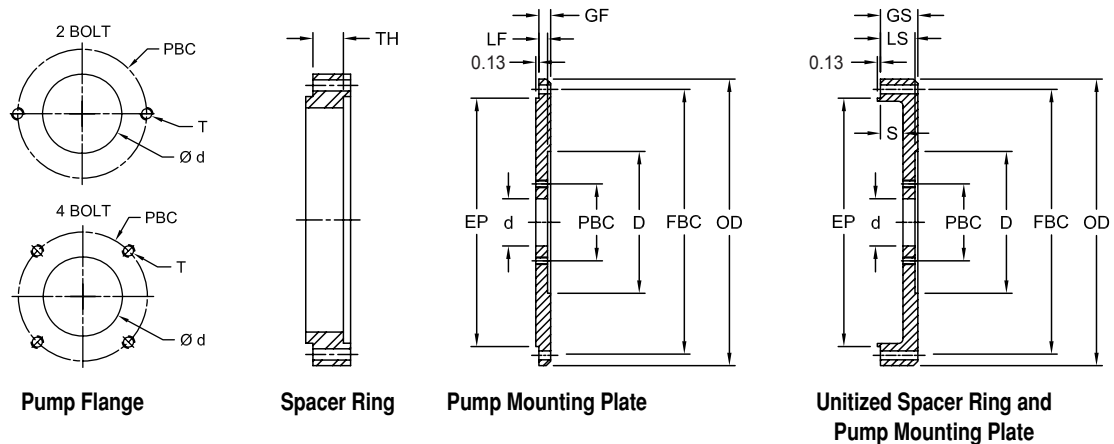

Pump Mounting Plates - SAE J744 Dimensional Data

Flywheel Housing SAE J617C Size	GF		LF		GS	LS	S	TH*		OD		FBC		EP	
	Pump Mounting Plate							Spacer Plate		Spacer Ring		Bolt Circle		Pilot Diameter	
	in	mm	in	mm				in	mm	in	mm	in	mm	in	mm
1	0.88	22.4	0.75	19.1	Based on customer request			0.88	23	21.75	552	20.875	530.2	20.125	511.2
2	0.88	22.4	0.75	19.1						19.25	489	18.375	466.7	17.625	447.7
3	0.50	12.7	0.44	11.2				0.63	16	17.75	451	16.875	428.6	16.125	409.6
4	0.50	12.7	0.44	11.2						15.88	403	15.000	381.0	14.250	362.0
5	0.50	12.7	0.44	11.2						14.00	356	13.125	333.4	12.375	314.3
6	0.50	12.7	0.44	11.2						12.13	308	11.250	285.8	10.500	266.7

Notes: ■ * indicates: Minimum thickness specified in chart. Total thickness is based on customer request.
 ■ For use with hydraulic pumps having standard SAE mountings and spline shafts.

Hydraulic Pump Mounting - SAE J744 Dimensional Data

Pump Mounting Flange	2 Bolt Design							4 Bolt Design						
	d		PBC		D		T	d		PBC		D		T
	Pilot Dia	Bolt Circle	Pump Face Dia	Thread Size	Pilot Dia	Bolt Circle	Pump Face Dia	Thread Size						
in	mm	in	mm	in	mm	in	mm	in	mm	in	mm	in	mm	
A-A	2.00	50.80	3.25	82.6	7	177.80	5/16-18	—	—	—	—	—	—	
A	3.25	82.55	4.18	106.4	7	177.80	3/8-16	—	—	—	—	—	—	
B & B-B	4.00	101.60	5.75	146.0	8	203.20	1/2-13	4.00	101.60	5.00	127.00	8	203.20	1/2-13
C & C-C	5.00	127.00	7.12	181.0	10	254.00	5/8-11	5.00	127.00	6.38	162.05	10	254.00	1/2-13
D	6.00	152.40	9.00	228.6	14	355.60	3/4-10	6.00	152.40	9.00	228.60	14	355.60	3/4-10
E	6.50	165.10	12.50	317.5	16	406.40	1-8	6.50	165.10	12.50	317.50	16	406.40	3/4-10
F	7.00	177.80	13.78	350.0	18	457.20	1-8	7.00	177.80	13.87	352.30	18	457.20	1-8

Note: ■ 6 bolt universal pump mounting design is available and is typical standard design.

Features

- Available in flat and spacer types
- SAE housing sizes 1 to 6
- SAE hydraulic pump size A to D
- DIN hydraulic pump pilot and bolt patterns also available
- Provides easy mounting to engine flywheel housing

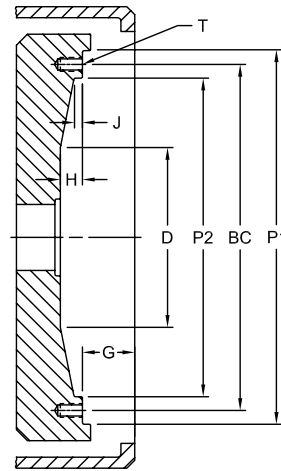

Pump Mounting Plates - SAE J620 Flywheel Dimensional Data

Nominal Clutch (flywheel) Size	P1		BC		P2		J		H		G		D		Tapped Holes	
	in	mm	in	mm	in	mm	in	mm	in	mm	in	mm	in	mm	Qty	Size
6.5	8.500	215.90	7.875	200.03	7.25	184.2	0.38	9.7	0.50	0.5	1.19	30.2	5.00	127.0	6	5/16-18
7.5	9.500	241.30	8.750	222.25	8.13	206.4	0.50	12.7	0.50	0.5	1.19	30.2	—	—	8	5/16-18
8	10.375	263.53	9.625	244.48	8.88	225.4	0.50	12.7	0.50	0.5	2.44	62.0	—	—	6	3/8-16
10	12.375	314.33	11.625	295.28	10.88	276.2	0.50	12.7	0.62	0.6	2.12	53.8	7.75	196.9	8	3/8-16
11.5	13.875	352.43	13.125	333.38	12.38	314.3	0.88	22.4	1.12	1.1	1.56	39.6	8.00	203.2	8	3/8-16
14	18.375	466.73	17.250	438.15	16.13	409.6	0.88	22.4	1.12	1.1	1.00	25.4	8.00	203.2	8	1/2-13
16	20.375	517.53	19.250	488.95	18.13	460.4	0.88	22.4	1.12	1.1	0.62	15.7	75.00	1905.0	8	1/2-13
18	22.500	571.50	21.375	542.93	19.63	498.5	1.25	31.8	1.25	1.3	0.62	15.7	10.00	254.0	6	5/8-11
21	26.500	673.10	25.250	641.35	23.00	684.2	1.15	29.2	1.25	1.3	—	—	—	—	12	5/8-11
24	28.875	733.43	27.250	692.15	25.38	644.5	1.25	31.8	1.25	1.3	—	—	—	—	12	3/4-10

Typical Flywheel Housing Combinations

SAE J620D Flywheel Size	LF Series Size	LK Series Size	SAE J617C Flywheel Housing					
			6	5	4	3	2	1
6.5	8 thru 28	100	▲	▲				
7.5	8 thru 28	100	●	●				
8	8 thru 30	100			▲			
10	8 thru 140	100, 125			●	▲	▲	
11.5	16 thru 140	100, 125, 150, 150D				●	●	▲
14	28 thru 250	150, UNIV						●
18	250	UNIV						●

Notes: ▲ indicates: Preferred combinations.
 ● indicates: Optoinal sizes available.

Pump Mounting Housings

Pump mounting housings are required to mount pumps on engines that do not have an SAE flywheel housing. Lovejoy offers pump mounting housings for the following engines. All are available with SAE pump mounting pilots and bolt patterns. Custom mounting pilots and bolt patterns available upon request. Housings are made of high strength Aluminum, designed to support the weight of the hydraulic pump without the need for a rear pump support mount. The LK80 and LK100 are available to match the flywheel options for the various engines and can be paired with the appropriate housing to provide a complete kit.



Cummins® B3.3
 Shown with LK100



Deutz® FL1001

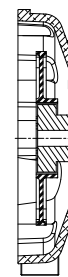

Ford® VSG 413
 Shown with LK100

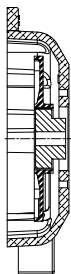

Ford® LRG 425
 Shown with LK100

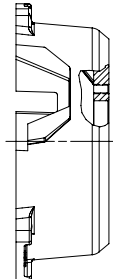

Kubota® Super Mini

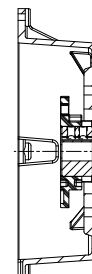

Kubota® Super 05
 Shown with LK80

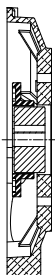

Kubota® Super 03
 Shown with LK100

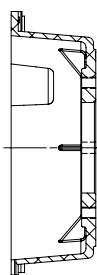

Perkins® 103-10
 Shown with LK100

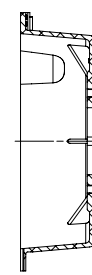

Perkins® 104-22
 Shown with LK100

T