



# BEVEL GEAR DRIVES

Selection of Units, Classes of Service,

Starting Torque, Thermal Capacity..... D-3

Quick Selection Tables..... D-4, D-5

## Rating and Dimensions

Models AD1, AD2..... D-6, D-7

Models AD3, AD4, AD5 ..... D-8, D-9

Model M2 ..... D-10, D-11

Model M3 ..... D-12, D-13

Model 44..... D-14, D-15

Model 11..... D-16, D-17

Model 150..... D-18, D-19

Model 165..... D-20, D-21

Model 175..... D-22, D-23

Model 66..... D-24, D-25

Model 65..... D-26, D-27

Model 600..... D-28, D-29

Model 88..... D-30, D-31

Models 800, 810..... D-32, D-33

Model 850..... D-34, D-35

Model 1000..... D-36, D-37

Model 1010..... D-38, D-39

Model 1050..... D-40, D-41

Model 1200..... D-42, D-43

Model 1250..... D-44, D-45

Model 1700..... D-46, D-47

Model 2200..... D-48, D-49

Model 790..... D-50, D-51

Model 920..... D-52, D-53

Model 950..... D-54, D-55

Metric Bevel Gear Drives..... D-56 to D-58

RA Series ..... D-59 to D-64

Accessories & Factory Options ..... D-65 to D-68





## **BEVEL GEAR DRIVES**

Over 40 Standard Models

### **BASIC SPECIFICATIONS**

- Power Ratings from .016 to 1250 hp
- Output Torque to 58,000 inch/lbs
- Ratios from 1:1 through 7.33:1
- Operating Speeds to 3600 rpm

### **STANDARD FEATURES**

- Universal Mounting Dimensions Assure Maximum Design Flexibility
- Ductile Iron or Cast Iron Housings Designed for Superior Thermal Conductivity Provides Rigid Gear and Bearing Support.
- Cast Aluminum Housings Provide Corrosion Resistance for Models AD1 through AD5
- Spiral Bevel or Straight Bevel Gearing Provides Efficient Operation and Durability
- Alloy Shafting for Greater Strength.
- Ball or Tapered Roller Bearings for Endurance and Strength
- Heavy-Duty Industrial Seals Keep Contaminants Out

### **OPTIONAL FEATURES**

- Modified Standard and Custom Designs
- C-Face or Hydraulic Motor Mounting Flanges
- Metric Versions to Meet Global Market Demands
- CleanLine Washdown and BISSC Configurations
- Unique or Harsh Environment Adaptations

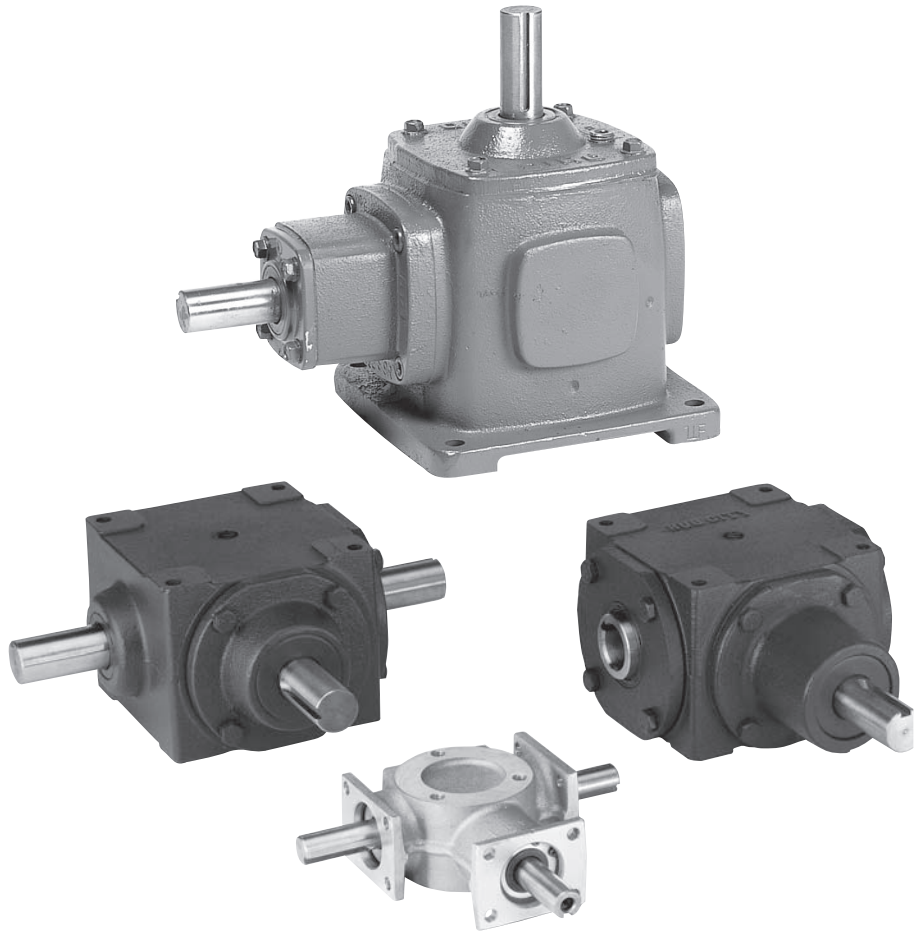

**For Stainless Steel  
Bevel Gear Drives  
See HUB<sup>®</sup>  
Section O**

**For Higher Ratio Bevel Drives  
See Poweratio<sup>®</sup> 2000  
Helical Bevel  
Section K**



## SELECTION OF BEVEL GEAR DRIVES

Bevel gear drives are selected on the basis of SPEED, RATIO, HORSEPOWER, and TORQUE. The QUICK SELECTION TABLES, page D4 & D-5 are designed to assist you in making a rapid selection of the model to fit your requirements. To use this table, find your required INPUT RPM and RATIO in the table and look across the page for the unit with the proper INPUT HORSEPOWER

for your application. For example, if the application INPUT SPEED is 1750 RPM and you require a 1:1 RATIO capable of transmitting 90 HORSEPOWER, from the chart the proper selection is a Model 88 with spiral bevel gears. The Table of Contents will guide you to the catalog pages containing complete engineering data and specifications for the model you have selected.

TABLE 1 – SERVICE FACTORS

PRIME MOVER	DURATION OF SERVICE PER DAY (1)	DRIVEN MACHINE LOAD CLASSIFICATION		
		UNIFORM	MEDIUM SHOCK	HEAVY SHOCK
Electric Motor	Occasional 1/2 hr.	*	*	1.25
	Intermittent 3 hrs.	*	1.00	1.50
	3 - 10 hours	1.00	1.25	1.75
	Over 10 hours	1.25	1.50	2.00
Electric Motor With Frequent Starts and Stops (2)	Occasional 1/2 hr.	*	1.00	1.50
	Intermittent 3 hrs.	1.00	1.25	1.75
	3 - 10 hours	1.25	1.50	2.00
	Over 10 hours	1.50	1.75	2.25
Multi-Cylinder Internal Combustion Engine	Occasional 1/2 hr.	*	1.00	1.50
	Intermittent 3 hrs.	1.00	1.25	1.75
	3 - 10 hours	1.25	1.50	2.00
	Over 10 hours	1.50	1.75	2.25
Single Cylinder Internal Combustion Engine	Occasional 1/2 hr.	1.00	1.25	1.75
	Intermittent 3 hrs.	1.25	1.50	2.00
	3 - 10 hours	1.50	1.75	2.25
	Over 10 hours	1.75	2.00	2.50
Reversing Service Application		Consult Factory		

\* UNSPECIFIED SERVICE FACTORS SHOULD BE 1.0 OR AS AGREED UPON BY USER AND MANUFACTURER.

### EXPLANATORY NOTES

1. Time specified for intermittent and occasional service refers to total operating time per day.
2. Term "frequent starts and stops" refers to more than 10 starts per hour.

### STARTING TORQUE

Momentary or starting torque should be limited to 200 per cent of rated capacity for Hub City Bevel gear drives.

### THERMAL CAPACITY

The thermal capacity of a unit is the maximum capacity at which the unit will operate at a temperature not exceeding 200° F. Under certain conditions of high load and high RPM the thermal capacity may be somewhat less than the mechanical capacity. If thermal capacity is exceeded, provision must be made for additional cooling of the unit or external recirculation of lubricant. Factory engineers are ready to assist designers with their problems, at all times.

### EFFICIENCY

Bevel Gearing and Ball or Tapered Roller Bearings provide a drive with very high efficiency. The approximate efficiency is 97.5%.

### SERVICE FACTORS

The ratings for gear drives in this manual are based on a service factor of 1.00, for uniform load and uniform power source, up to 10 hours of operation per day. For other operating conditions, the application horsepower or torque must be multiplied by the appropriate service factor, to determine the equivalent gear drive power rating. A gear drive should be selected with a rated capacity equal to or greater than the equivalent rating. Table 1 designates recommended service factors for various conditions of load, power source, and duration of service.

AGMA Service Factors for Drives and Reducers are listed on pages A-7 to A-8.

Refer to page A-2 for further information and cautions on the selection of proper service factors.

### APPLICATIONS

Bevel Gear Drives transfer power at 90°. Generally this power transfer is a 1:1 ratio with relation to speed. These gear drives are also capable of increasing or reducing speed.

### SHAFT ROTATION

Shaft rotation is determined by the relative location of the gears. Right hand (clockwise) or left hand (counter - clockwise) rotations are determined by viewing the end of the shaft. Pinion shaft can be rotated in either direction.

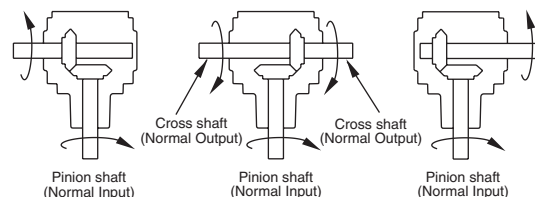

The above illustrations show common terms normally used in discussing Bevel Gear Drives.



## QUICK MODEL SELECTION

STRAIGHT BEVEL GEAR DRIVES BY INPUT HORSEPOWER														
INPUT RPM	RATIO	OUTPUT RPM	M2 M3	RA-0	44	11	150	165	66	600	88	800	810	1000
2400	1:1	2400	3.00											
	1.47:1	1644				8.0								
	1.5:1	1600	2.10											
	1.8:1	1333				7.3								
	2:1	1200	1.40				9.0	9.0						
1750	1:1	1750	2.25	2.0	20.0									
	1.43:1	1225			10.1									
	1.47:1	1199				6.1								
	1.5:1	1168	1.57				9.2	9.2	15.0					
	1.8:1	972				5.4								
	2:1	875	1.04	2.5	5.90		6.3	6.3	7.3					
3:1	583		1.7							15.0				
1150	1:1	1150	1.50	1.50	13.8	12.0	12.0	17.0	24.2	34.0				
	1.36:1	852							11.4					
	1.43:1	805			6.9									
	1.47:1	788				4.2								
	1.5:1	767	1.03				6.2	6.2	10.6		39.0	44.0	44.0	
	1.7:1	676										33.0	33.0	
	1.8:1	638				3.6								
	2:1	575	.70	1.9	4.1		4.3	4.3	5.4		22.0			
3:1	383		1.3							9.9				
690	1:1	690	.93	1.0	8.4	7.6	7.6	10.6	16.3	23.9	36.5	56.2	56.2	80.0
	1.21:1	575										40.0	40.0	55.0
	1.33:1	519										37.0	37.0	
	1.36:1	511							7.2					
	1.43:1	483			4.3									
	1.47:1	473				2.6								
	1.5:1	460	.65				3.9	3.9	7.1		24.0	28.0	28.0	
	1.7:1	406										21.6	21.6	
	1.8:1	383				2.2								
	1.87:1	369												39.0
	2:1	345	.43	1.3	2.5		2.7	2.7	3.9		13.8			
2.21:1	314												26.0	
3:1	230		.93							6.5				
100	1:1	100	.14	.25	1.2	1.2	1.2	1.7	2.9	4.3	5.8	9.0	9.0	17.0
	1.21:1	83										6.7	6.7	11.0
	1.33:1	75										6.1	6.1	
	1.36:1	74							1.4					
	1.43:1	70			.71									
	1.47:1	68				.44								
	1.5:1	66	.12				.65	.65	1.4		3.8	4.6	4.6	
	1.7:1	59										3.4	3.4	
	2:1	50		.30	.41		.50	.50	.70		2.3			
	2.2:1	45												4.8
3:1	33		.20											



# QUICK MODEL SELECTION

SPIRAL BEVEL GEAR DRIVES BY INPUT HORSEPOWER																			
INPUT RPM	RATIO	OUTPUT RPM	AD1 AD4	AD2 AD5	AD3	RA-1	11 150 165 175	RA-2	65 66	RA-3	600	88	RA-4	800 810 850	1010 1050	1200	1250	1700	2200
3600	1:1	3600	1.81	4.31	10.25														
	2:1	1800	.53	2.12	3.82														
2400	1:1	2400	1.24	2.95	7.10	17.6	21.8	27.3	59.0	51.3	59.0								
	1.29:1	1860									46.3								
	1.53:1	1569							46.0										
	2:1	1200	.36	1.45	2.62	12.8	12.3	19.1	20.7	49.6									
1750	3:1	800					7.0		12.5										
	1:1	1750	.91	2.19	5.27	14.1	16.0	21.9	46.0	41.1	46.0	90.0	52.2	132	251	296	380	701	1250
	1.29:1	1356									34.7								
	1.33:1	1316													195	232		334	491
	1.5:1	1167										69.9		69.9	173	205	205	301	480
	1.53:1	1143							35.0										
	2:1	875	.26	1.07	1.96	10.3	9.0	15.3	15.4	39.6		56.0	49.5	56.0	124	235	235	305	
3:1	583				6.5		13.1	9.2	27.3		30.7	40.2	30.7	55.8	133	133	159	237	
1150	1:1	1150	.61	1.47	3.55	10.5	11.0	16.3	30.5	30.0	30.5	63.0	38.9	90.0	173	204	261	482	868
	1.29:1	891									23.6								
	1.33:1	865													134	164		228	337
	1.5:1	767										47.0		47.0	118	145	145	206	330
	1.53:1	751							23.0										
	2:1	575	.18	.72	1.32	7.5	6.1	10.9	10.3	27.3		38.0	36.9	38.0	84.4	166	166	210	
	3:1	383				4.5		9.7	6.2	18.7		20.6	30.0	20.6	37.7	93.0	93.0	108	162
690	1:1	690	.37	.90	2.19	7.3	6.8	11.4	20.0	18.8	20.0	39.5	27.2	56.0	109	128	165	305	549
	1.29:1	535									14.6								
	1.33:1	519													83.5	112		144	212
	1.5:1	460										29.5		29.5	73.8	85.0	85.0	130	208
	1.53:1	451							15.0										
	2:1	345	.11	.44	.81	4.7	3.7	6.9	6.3	17.3		23.0	25.8	23.0	52.5	113	113	132	
	3:1	230				2.8		6.1	3.8	11.8		12.6	20.9	12.6	28.4	61.0	61.0	67.0	101
100	1:1	100	.06	.14	.34	1.3	1.1	2.2	3.7	3.2	3.7	6.5	5.2	9.0	18.5	21.0	27.0	50.0	92.0
	1.29:1	77									2.3								
	1.33:1	75													13.1	20.0		23.0	35.0
	1.5:1	67										4.8		4.8	11.8	18.0	18.0	21.0	34.0
	1.53:1	65							3.0										
	2:1	50	.02	.07	.13	.77	.55	1.1	.95	2.9		3.6	5.3	3.6	8.3	20.0	20.0	21.0	
	3:1	33				.45		1.0	.55	1.9		1.9	3.5	1.9	3.7	10.0	10.0	11.0	16.0



### BEVEL GEAR DRIVE NOMENCLATURE EXAMPLES

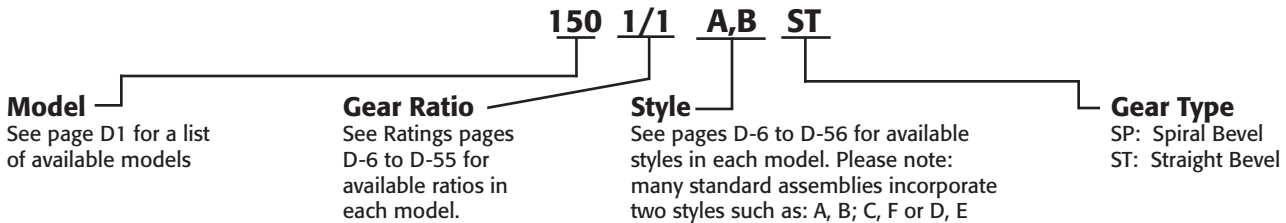

### RA SERIES

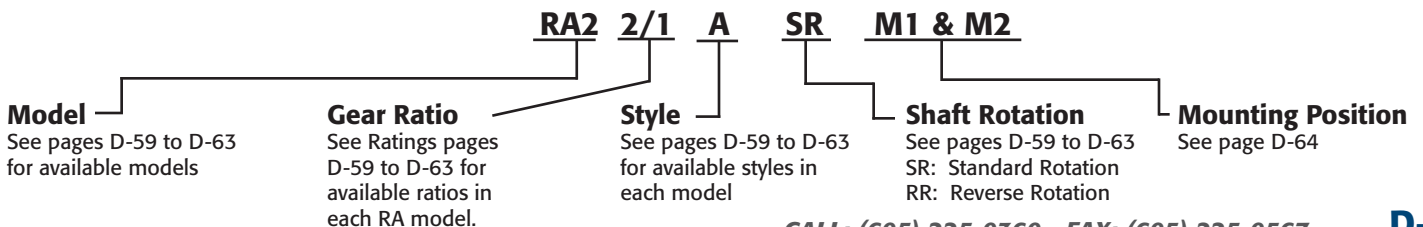



## MODELS AD1, AD2

### FEATURES

- Cast aluminum housing designed to resist corrosion and provide rigid gear and bearing support.
- Stainless steel or chrome plated shaft provide resistance to corrosion.
- Precision ball bearings to accommodate higher operating speeds.
- Spiral bevel gearing to assure low noise level at higher operating speeds.
- Permanently lubricated at factory to assure trouble free service.
- Universal mounting (4 surfaces) to assure maximum design flexibility.



### RATING TABLE

INPUT RPM†		MODEL AD1 RATIO		MODEL AD2 RATIO	
		1:1	2:1Δ	1:1	2:1Δ
3600	INPUT HORSEPOWER	1.810	.525	4.310	2.120
	OUTPUT TORQUE IN. LBS.	31.700	18.400	75.500	74.200
2400	INPUT HORSEPOWER	1.240	.356	2.950	1.450
	OUTPUT TORQUE IN. LBS.	32.500	18.700	77.400	76.100
1750	INPUT HORSEPOWER	.913	.262	2.190	1.070
	OUTPUT TORQUE IN. LBS.	32.900	18.900	78.700	77.200
1150	INPUT HORSEPOWER	.609	.176	1.470	.720
	OUTPUT TORQUE IN. LBS.	33.400	19.300	80.300	78.600
850	INPUT HORSEPOWER	.457	.131	1.100	.540
	OUTPUT TORQUE IN. LBS.	33.900	19.500	81.300	79.400
690	INPUT HORSEPOWER	.374	.108	.900	.440
	OUTPUT TORQUE IN. LBS.	34.200	19.700	81.900	80.000
400	INPUT HORSEPOWER	.220	.064	.530	.260
	OUTPUT TORQUE IN. LBS.	34.700	20.000	83.300	81.200
200	INPUT HORSEPOWER	.112	.033	.270	.130
	OUTPUT TORQUE IN. LBS.	35.100	20.300	84.700	82.400
100	INPUT HORSEPOWER	.057	.016	.140	.070
	OUTPUT TORQUE IN. LBS.	35.600	20.500	85.800	83.200

†FOR HIGHER INPUT SPEEDS CONSULT FACTORY

Δ2:1 RATIO HAS PLATED PINION SHAFTS

### STANDARD STYLES AVAILABLE

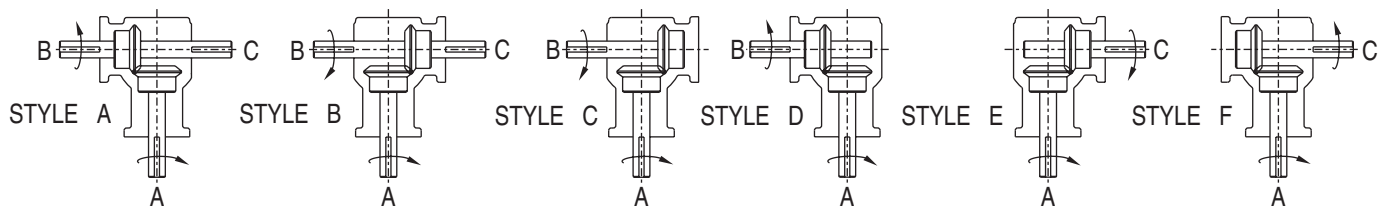

CONSULT FACTORY FOR VERTICAL SHAFT LUBRICATION RECOMMENDATIONS  
INPUT SHAFT CAN BE ROTATED IN EITHER DIRECTION



# MODELS AD1, AD2

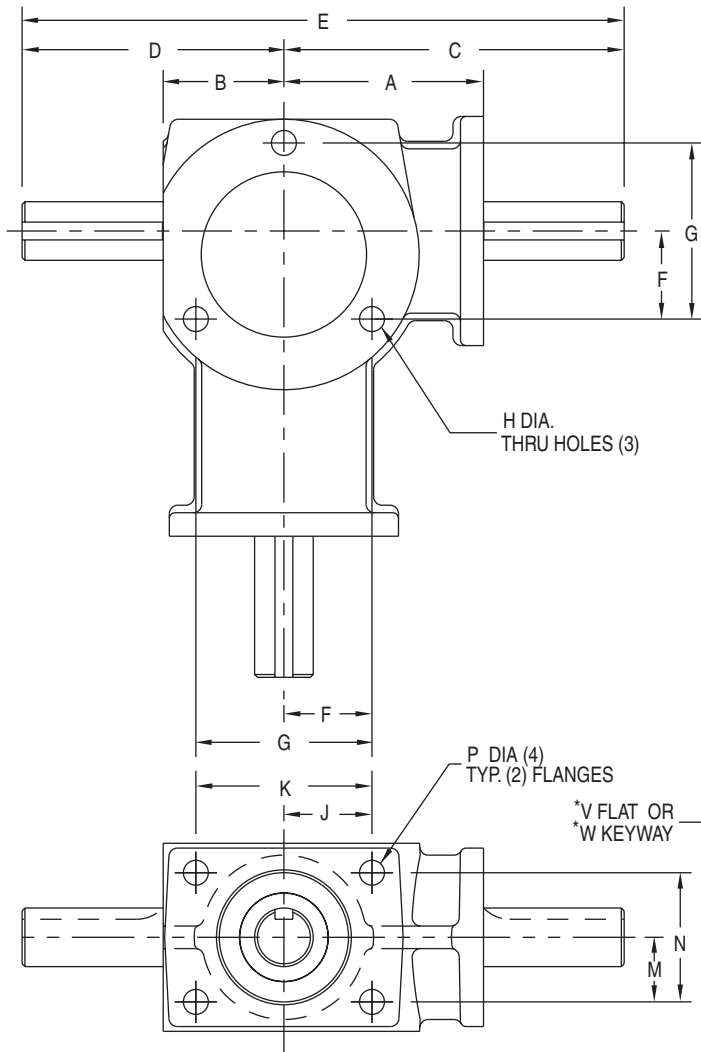

### ALLOWABLE SHAFT LOADS ALL RATIOS AND SHAFTS

MODEL NO.	OVERHUNG LOAD**	THRUST LOAD
AD 1	25 lbs.	50 lbs.
AD 2	50 lbs.	100 lbs.

\*\* ASSUMES LOAD AT MIDPOINT OF SHAFT EXTENSION

FOR LUBRICATION AND INSTALLATION INSTRUCTIONS - REFER TO SECTION R

\* DIMENSIONS TYPICAL ALL SHAFT EXTENSIONS

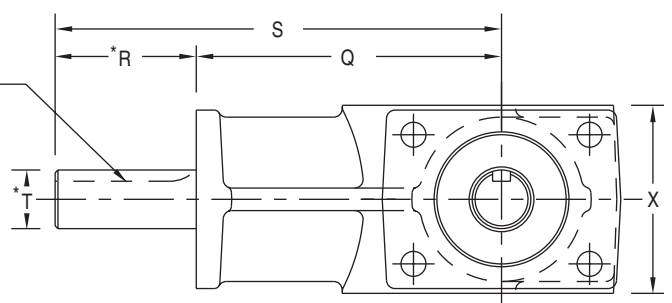

### SHIPPING WEIGHTS

MODEL AD1 .....1/2 lb.  
MODEL AD2 .....2 lbs.

INPUT SHAFT CAN BE ROTATED IN EITHER DIRECTION

DIMENSIONS SHOWN ARE FOR REFERENCE ONLY.  
CERTIFIED PRINTS ARE AVAILABLE UPON REQUEST.

MODEL NO.	A	B	C	D	E	F	G	H	J	K	M	N	P
AD1	1-3/8	31/32	1-31/32	1-9/16	3-17/32	.656	1.312	13/64	.594	1.188	.438	.875	11/64
AD2	2-1/8	1-9/32	3-5/8	2-25/32	6-13/32	.937	1.875	17/64	.937	1.875	.687	1.375	17/64

MODEL NO.	Q	R	S	T	V	W	X
AD1	2-5/32	19/32	2-3/4	.3745/.3740	1/32 DEEP	.60 EFF. FLAT	1.255/1.250
AD2	3-1/4	1-1/2	4-3/4	.6245/.6240	-	3/16 X 3/32 1-7/32 EFF. LGTH.	2.005/2.000





## MODELS AD3, AD4, AD5

### FEATURES

- Cast aluminum housing designed to resist corrosion and provide rigid gear and bearing support.
- Stainless steel or chrome plated shaft provide resistance to corrosion.
- Precision ball bearings to accommodate higher operating speeds.
- Spiral bevel gearing to assure low noise level at higher operating speeds.
- Permanently lubricated at factory to assure trouble free service.
- Universal mounting (5 surfaces) to assure maximum design flexibility.
- Metric versions available. (Refer to page D-56)

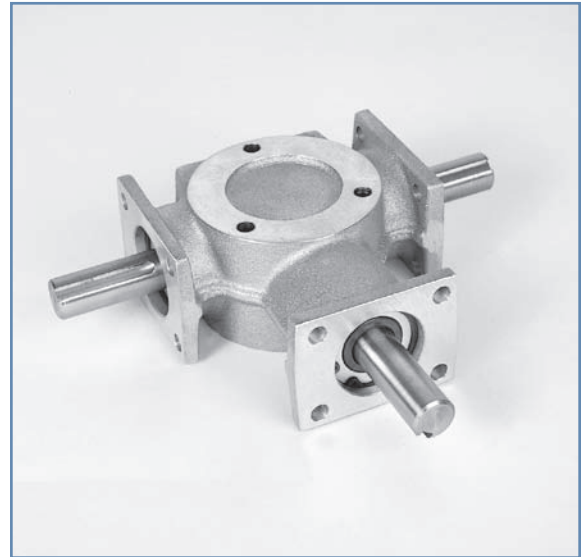

### RATING TABLE

INPUT RPM†		MODEL AD4 RATIO		MODEL AD5 RATIO		MODEL AD3 RATIO	
		1:1	2:1 $\Delta$	1:1	2:1 $\Delta$	1:1	2:1 $\Delta$
3600	INPUT HORSEPOWER	1.810	.525	4.310	2.120	10.250	3.820
	OUTPUT TORQUE IN. LBS.	31.700	18.400	75.500	74.200	179.560	133.800
2400	INPUT HORSEPOWER	1.240	.356	2.950	1.450	7.100	2.620
	OUTPUT TORQUE IN. LBS.	32.500	18.700	77.400	76.100	186.400	137.600
1750	INPUT HORSEPOWER	.913	.262	2.190	1.070	5.270	1.960
	OUTPUT TORQUE IN. LBS.	32.900	18.900	78.700	77.200	189.700	141.000
1150	INPUT HORSEPOWER	.609	.176	1.470	.720	3.550	1.320
	OUTPUT TORQUE IN. LBS.	33.400	19.300	80.300	78.600	194.800	144.400
850	INPUT HORSEPOWER	.457	.131	1.100	.540	2.670	.990
	OUTPUT TORQUE IN. LBS.	33.900	19.500	81.300	79.400	198.000	146.800
690	INPUT HORSEPOWER	.374	.108	.900	.440	2.190	.810
	OUTPUT TORQUE IN. LBS.	34.200	19.700	81.900	80.000	200.100	148.200
400	INPUT HORSEPOWER	.220	.064	.530	.260	1.300	.480
	OUTPUT TORQUE IN. LBS.	34.700	20.000	83.300	81.200	204.800	151.200
200	INPUT HORSEPOWER	.112	.033	.270	.130	.670	.250
	OUTPUT TORQUE IN. LBS.	35.100	20.300	84.700	82.400	209.400	154.400
100	INPUT HORSEPOWER	.057	.016	.140	.070	.340	.130
	OUTPUT TORQUE IN. LBS.	35.600	20.500	85.800	83.200	212.900	156.600

†FOR HIGHER INPUT SPEEDS CONSULT FACTORY

$\Delta$ 2:1 RATIO HAS PLATED PINION SHAFTS

### STANDARD STYLES AVAILABLE

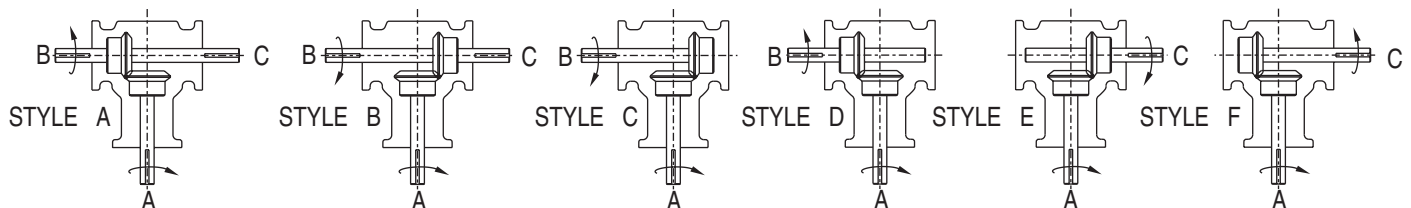

CONSULT FACTORY FOR VERTICAL SHAFT LUBRICATION RECOMMENDATIONS  
INPUT SHAFT CAN BE ROTATED IN EITHER DIRECTION





## MODELS AD3, AD4, AD5

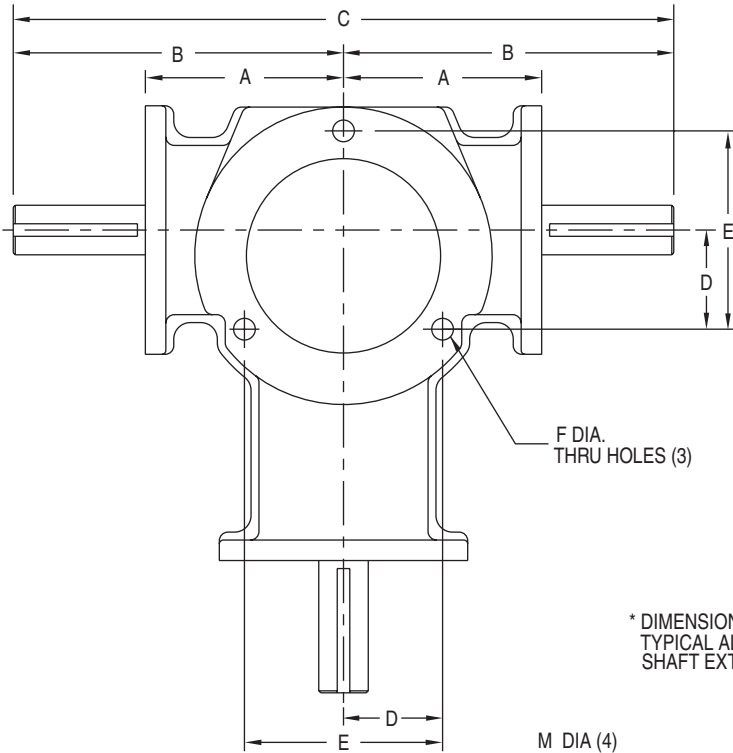

### ALLOWABLE SHAFT LOADS ALL RATIOS AND SHAFTS

MODEL NO.	OVERHUNG LOAD**	THRUST LOAD
AD 3	100 lbs.	200 lbs.
AD 4	25 lbs.	50 lbs.
AD 5	50 lbs.	100 lbs.

\*\* ASSUMES LOAD AT MIDPOINT OF SHAFT EXTENSION

### FOR LUBRICATION AND INSTALLATION INSTRUCTIONS - REFER TO SECTION R

\* DIMENSIONS  
TYPICAL ALL  
SHAFT EXTENSIONS

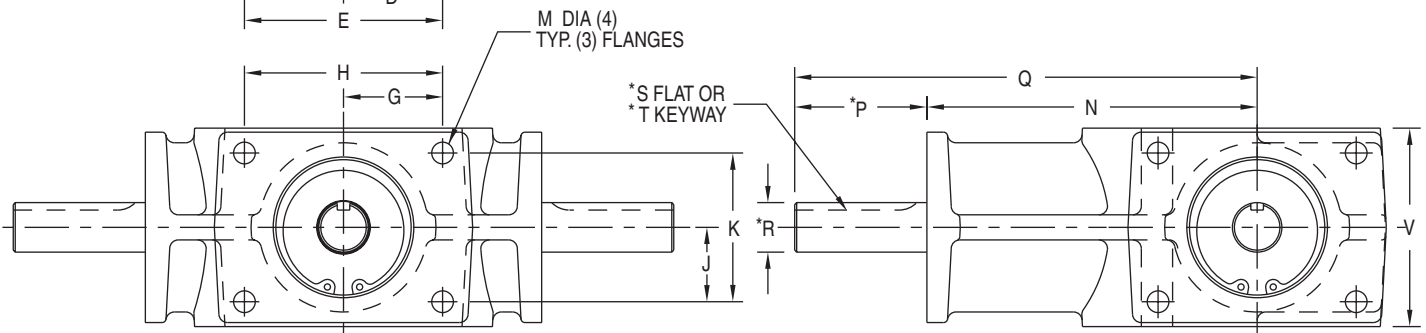

### SHIPPING WEIGHTS

MODEL AD3	8-1/4 lbs.
MODEL AD4	1/2 lb.
MODEL AD5	.2 lbs.

DIMENSIONS SHOWN ARE FOR REFERENCE ONLY.  
CERTIFIED PRINTS ARE AVAILABLE UPON REQUEST.

INPUT SHAFT CAN BE ROTATED IN EITHER DIRECTION

MODEL NO.	A	B	C	D	E	F	G	H	J	K	M
AD3	3	5	10	1.500	3.000	21/64	1.500	3.000	1.125	2.250	21/64
AD4	1-3/8	1-63/64	3-61/64	.656	1.312	17/64	.594	1.188	.438	.875	11/64
AD5	2-1/8	3-5/8	7-1/4	.937	1.875	17/64	.937	1.875	.687	1.375	17/64

MODEL NO.	N	P	Q	R	S	T	V
AD3	5	2	7	.750/.749	—	3/16 X 3/32 1-9/16 EFF. LGTH.	3.005/3.000
AD4	2-5/32	19/32	2-3/4	.3745/.3740	1/32 DEEP	.60 EFF. FLAT	1.255/1.250
AD5	3-1/4	1-1/2	4-3/4	.6245/.6240	—	3/16 X 3/32 1-7/32 EFF. LGTH.	2.005/2.000



## MODEL M2

### FEATURES

- Rugged cast iron housing designed for rigid gear and bearing support.
- Alloy shafting for greater strength.
- Precision ball bearings to accommodate higher operating speeds.
- Choice of seven (7) gear ratios.
- Heavy-duty industrial seals to keep lubricant in and dirt out.
- Universal mounting assures maximum design flexibility.
- Hub City lubricant recommended. (Refer to section R)

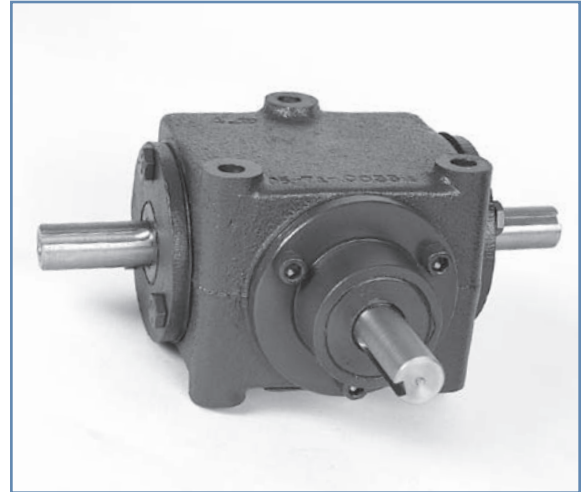

### RATING TABLE

INPUT RPM†		REDUCTION RATIOS					*INCREASER RATIOS	
		1:1	SPIRAL 1:1Δ	1.5:1	2:1	SPIRAL 2:1Δ	1:1.5	1:2
3000	INPUT HORSEPOWER		3.59	2.60	1.75	1.77		
	OUTPUT TORQUE IN. LBS.		75.50	82.00	73.00	74.20		
	‡INPUT O.H.L.		25.00	72.00	83.00	30.00		
	‡OUTPUT O.H.L.		70.00	200.00	245.00	100.00		
2400	INPUT HORSEPOWER	3.00	2.95	2.10	1.40	1.45		
	OUTPUT TORQUE IN. LBS.	79.00	77.40	83.00	74.00	76.10		
	‡INPUT O.H.L.	67.00	45.00	85.00	90.00	50.00		
	‡OUTPUT O.H.L.	155.00	105.00	220.00	270.00	135.00		
1750	INPUT HORSEPOWER	2.25	2.19	1.57	1.04	1.07	2.10	
	OUTPUT TORQUE IN. LBS.	81.00	78.70	84.00	75.00	77.20	50.00	
	‡INPUT O.H.L.	88.00	60.00	98.00	102.00	70.00	95.00	
	‡OUTPUT O.H.L.	177.00	150.00	245.00	300.00	180.00	89.00	
1150	INPUT HORSEPOWER	1.50	1.47	1.03	.70	.72	1.40	1.20
	OUTPUT TORQUE IN. LBS.	83.00	80.30	85.00	77.00	78.60	51.00	33.00
	‡INPUT O.H.L.	110.00	90.00	118.00	121.00	95.00	114.00	110.00
	‡OUTPUT O.H.L.	205.00	175.00	290.00	350.00	210.00	104.00	96.00
850	INPUT HORSEPOWER	1.13	1.10	.80	.53	.54	1.05	.92
	OUTPUT TORQUE IN. LBS.	84.00	81.30	88.00	78.00	79.40	51.50	34.00
	‡INPUT O.H.L.	131.00	100.00	137.00	142.00	105.00	134.00	128.00
	‡OUTPUT O.H.L.	240.00	210.00	320.00	382.00	240.00	119.00	111.00
690	INPUT HORSEPOWER	.93	.90	.65	.43	.44	.86	.76
	OUTPUT TORQUE IN. LBS.	85.00	81.90	89.00	80.00	80.00	50.00	34.50
	‡INPUT O.H.L.	137.00	110.00	144.00	148.00	112.00	140.00	136.00
	‡OUTPUT O.H.L.	267.00	230.00	350.00	400.00	270.00	126.00	118.00
400	INPUT HORSEPOWER	.55	.53	.39	.26	.26	.50	.45
	OUTPUT TORQUE IN. LBS.	87.00	83.30	92.00	82.00	81.20	53.00	35.50
	‡INPUT O.H.L.	169.00	125.00	175.00	180.00	138.00	173.00	168.00
	‡OUTPUT O.H.L.	330.00	300.00	400.00	400.00	330.00	157.00	149.00
300	INPUT HORSEPOWER	.42	.40	.30	.20	.19	.40	.34
	OUTPUT TORQUE IN. LBS.	88.00	84.70	95.00	83.00	82.40	56.00	36.00
	‡INPUT O.H.L.	189.00	150.00	190.00	190.00	152.00	190.00	185.00
	‡OUTPUT O.H.L.	378.00	400.00	400.00	400.00	400.00	173.00	164.00
100	INPUT HORSEPOWER	.14	.14	.12	.08	.07	.14	.12
	OUTPUT TORQUE IN. LBS.	90.00	85.80	113.00	100.00	83.20	59.00	38.00
	‡INPUT O.H.L.	190.00	160.00	190.00	190.00	175.00	190.00	190.00
	‡OUTPUT O.H.L.	400.00	400.00	400.00	400.00	400.00	190.00	190.00

†FOR HIGHER INPUT SPEEDS CONSULT FACTORY.  
\*AVAILABLE IN STYLE "G" ONLY.

‡OVERHUNG LOAD IN POUNDS AT CENTER OF SHAFT EXTENSIONS.  
ΔMFG. TO ORDER - CONSULT FACTORY FOR PRICE AND DELIVERY.



# MODEL M2

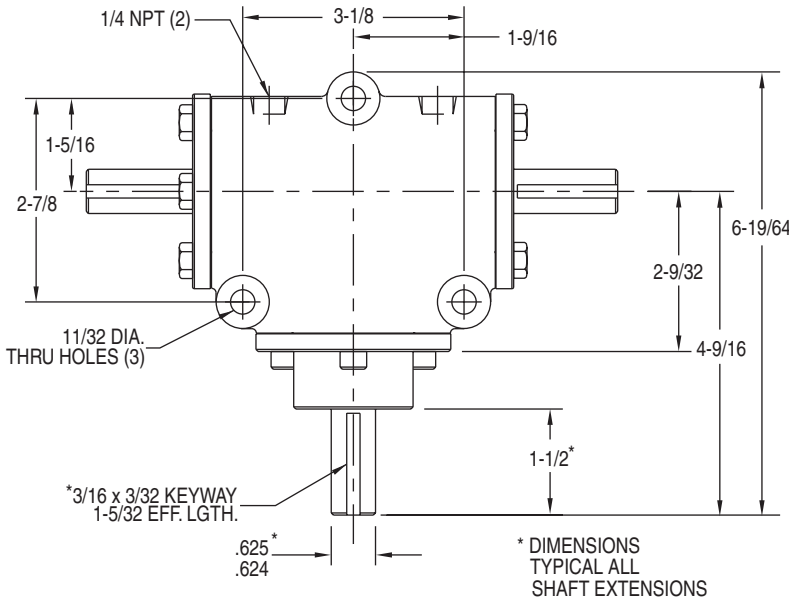

**NOTE: STYLE G**

1. DIMENSIONS FOR SHAFTS A, A1, AND A2 ARE IDENTICAL FOR ALL RATIOS.
2. CENTERLINE TO END OF SHAFT DIMENSIONS WILL VARY. REQUEST CERTIFIED DIMENSIONAL PRINTS.

FOR LUBRICATION AND INSTALLATION INSTRUCTIONS - REFER TO SECTION R

D

RATING AND DIMENSIONS

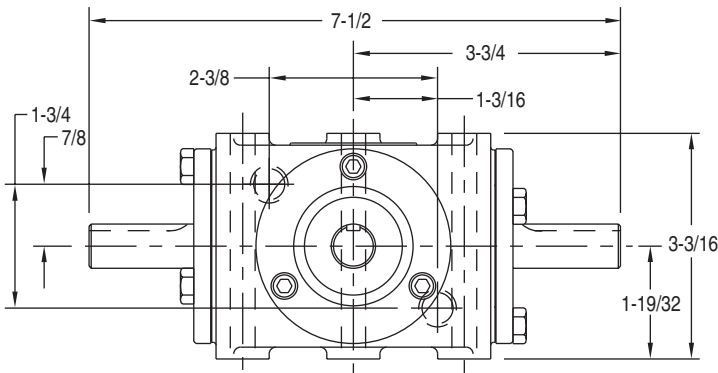

**DRY SHIPPING WEIGHTS**

STYLES A, B, C, D, E, F .....9 lbs.

STYLES G .....10 lbs.

DIMENSIONS SHOWN ARE FOR REFERENCE ONLY. CERTIFIED PRINTS ARE AVAILABLE UPON REQUEST.

**STANDARD STYLES AVAILABLE**

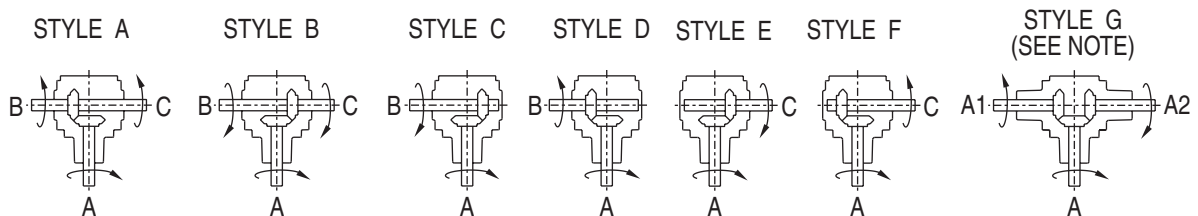

CONSULT FACTORY FOR VERTICAL SHAFT LUBRICATION RECOMMENDATIONS  
INPUT SHAFT CAN BE ROTATED IN EITHER DIRECTION



## MODEL M3

### FEATURES

- Rugged cast iron housing designed for rigid gear and bearing support.
- Alloy shafting for greater strength.
- Precision ball bearings to accommodate higher operating speeds.
- Choice of seven (7) gear ratios.
- Heavy-duty industrial seals to keep lubricant in and dirt out.
- Universal mounting assures maximum design flexibility.
- Hub City lubricant recommended. (Refer to section R)
- Metric versions available. (Refer to page D-57)

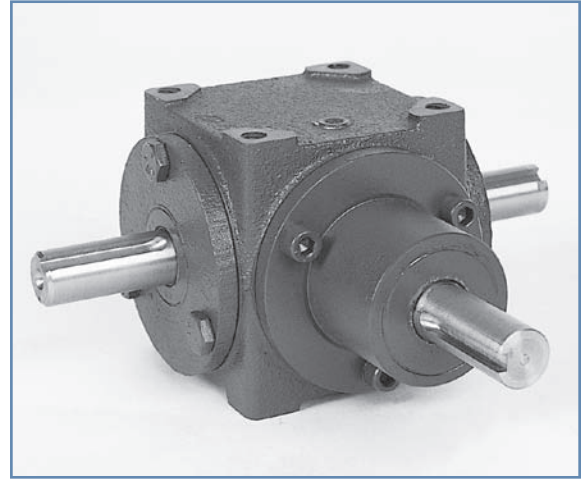

### RATING TABLE

INPUT RPM†		REDUCTION RATIOS					*INCREASER RATIOS	
		1:1	SPIRAL 1:1Δ	1.5:1	2:1	SPIRAL 2:1Δ	1:1.5	1:2
3000	INPUT HORSEPOWER		3.59	2.60	1.75	1.77		
	OUTPUT TORQUE IN. LBS.		75.50	82.00	73.00	74.20		
	‡INPUT O.H.L.		25.00	72.00	83.00	30.00		
	‡OUTPUT O.H.L.		70.00	200.00	245.00	100.00		
2400	INPUT HORSEPOWER	3.00	2.95	2.10	1.40	1.45		
	OUTPUT TORQUE IN. LBS.	79.00	77.40	83.00	74.00	76.10		
	‡INPUT O.H.L.	67.00	45.00	85.00	90.00	50.00		
	‡OUTPUT O.H.L.	155.00	105.00	220.00	270.00	135.00		
1750	INPUT HORSEPOWER	2.25	2.19	1.57	1.04	1.07	2.10	
	OUTPUT TORQUE IN. LBS.	81.00	78.70	84.00	75.00	77.20	50.00	
	‡INPUT O.H.L.	88.00	60.00	98.00	102.00	70.00	95.00	
	‡OUTPUT O.H.L.	177.00	150.00	245.00	300.00	180.00	89.00	
1150	INPUT HORSEPOWER	1.50	1.47	1.03	.70	.72	1.40	1.20
	OUTPUT TORQUE IN. LBS.	83.00	80.30	85.00	77.00	78.60	51.00	33.00
	‡INPUT O.H.L.	110.00	90.00	118.00	121.00	95.00	114.00	110.00
	‡OUTPUT O.H.L.	205.00	175.00	290.00	350.00	210.00	104.00	96.00
850	INPUT HORSEPOWER	1.13	1.10	.80	.53	.54	1.05	.92
	OUTPUT TORQUE IN. LBS.	84.00	81.30	88.00	78.00	79.40	51.50	34.00
	‡INPUT O.H.L.	131.00	100.00	137.00	142.00	105.00	134.00	128.00
	‡OUTPUT O.H.L.	240.00	210.00	320.00	382.00	240.00	119.00	111.00
690	INPUT HORSEPOWER	.93	.90	.65	.43	.44	.86	.76
	OUTPUT TORQUE IN. LBS.	85.00	81.90	89.00	80.00	80.00	50.00	34.50
	‡INPUT O.H.L.	137.00	110.00	144.00	148.00	112.00	140.00	136.00
	‡OUTPUT O.H.L.	267.00	230.00	350.00	400.00	270.00	126.00	118.00
400	INPUT HORSEPOWER	.55	.53	.39	.26	.26	.50	.45
	OUTPUT TORQUE IN. LBS.	87.00	83.30	92.00	82.00	81.20	53.00	35.50
	‡INPUT O.H.L.	169.00	125.00	175.00	180.00	138.00	173.00	168.00
	‡OUTPUT O.H.L.	330.00	300.00	400.00	400.00	330.00	157.00	149.00
300	INPUT HORSEPOWER	.42	.40	.30	.20	.19	.40	.34
	OUTPUT TORQUE IN. LBS.	88.00	84.70	95.00	83.00	82.40	56.00	36.00
	‡INPUT O.H.L.	189.00	150.00	190.00	190.00	152.00	190.00	185.00
	‡OUTPUT O.H.L.	378.00	400.00	400.00	400.00	400.00	173.00	164.00
100	INPUT HORSEPOWER	.14	.14	.12	.08	.07	.14	.12
	OUTPUT TORQUE IN. LBS.	90.00	85.80	113.00	100.00	83.20	59.00	38.00
	‡INPUT O.H.L.	190.00	160.00	190.00	190.00	175.00	190.00	190.00
	‡OUTPUT O.H.L.	400.00	400.00	400.00	400.00	400.00	190.00	190.00

†FOR HIGHER INPUT SPEEDS CONSULT FACTORY.

\*AVAILABLE IN STYLE "G" ONLY.

‡OVERHUNG LOAD IN POUNDS AT CENTER OF SHAFT EXTENSIONS.

ΔMFG. TO ORDER - CONSULT FACTORY FOR PRICE AND DELIVERY.



# MODEL M3

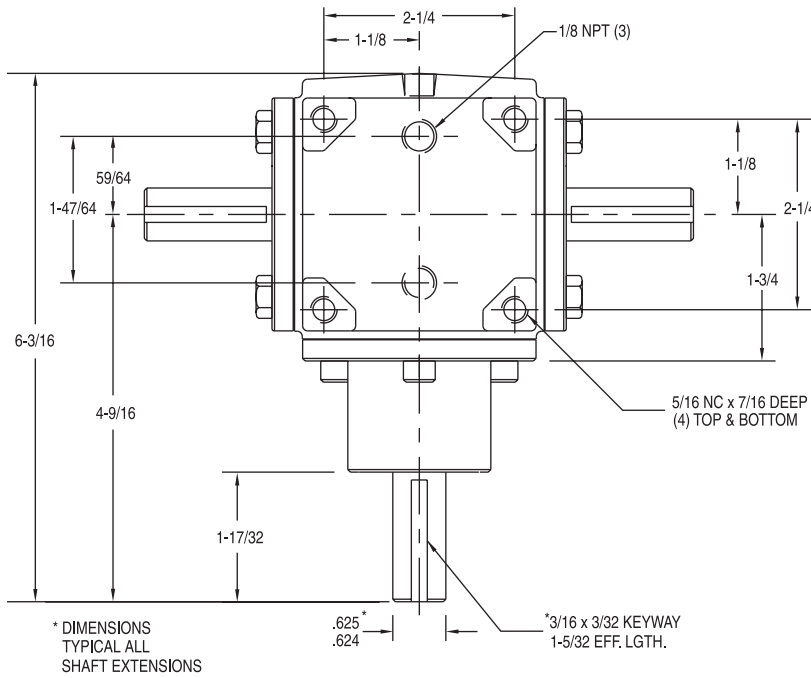

**NOTE: STYLE G & GG**

1. DIMENSIONS FOR SHAFTS A, A1, AND A2 ARE IDENTICAL FOR ALL RATIOS.
2. CENTERLINE TO END OF SHAFT DIMENSIONS WILL VARY. REQUEST CERTIFIED DIMENSIONAL PRINTS.

**FOR LUBRICATION AND INSTALLATION INSTRUCTIONS - REFER TO SECTION R**

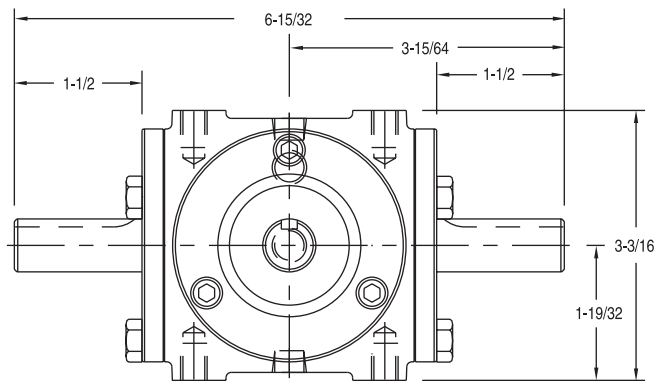

**DRY SHIPPING WEIGHTS**

- STYLES A, B, C, D, E, F .....10 lbs.
- STYLES G .....12 lbs.
- STYLES GG .....15 lbs.

**STANDARD STYLES AVAILABLE**

DIMENSIONS SHOWN ARE FOR REFERENCE ONLY. CERTIFIED PRINTS ARE AVAILABLE UPON REQUEST.

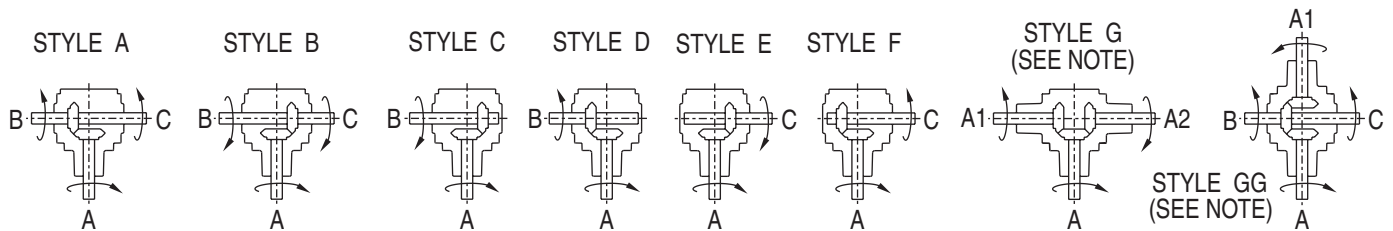

CONSULT FACTORY FOR VERTICAL SHAFT LUBRICATION RECOMMENDATIONS  
INPUT SHAFT CAN BE ROTATED IN EITHER DIRECTION

D

RATING AND DIMENSIONS



## MODEL 44

### FEATURES

- Rugged cast iron housing designed for rigid gear and bearing support.
- Alloy shafting for greater strength.
- Tapered roller bearings for endurance and strength.
- Choice of three (3) gear ratios.
- Heavy-duty industrial seals to keep lubricant in and dirt out.
- Universal mounting assures maximum design flexibility.
- Hub City lubricant recommended. (Refer to section R)

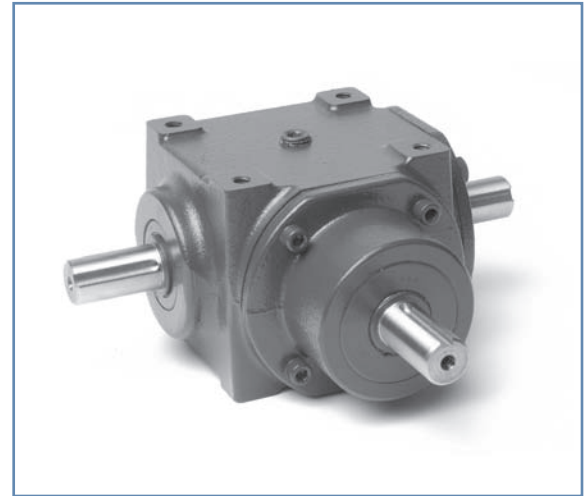

### RATING TABLE

<b>INPUT RPM†</b>		<b>1:1 ST</b>	<b>1.428:1 ST</b>	<b>2:1 ST</b>
<b>1750</b>	INPUT HORSEPOWER	19.96	10.05	5.95
	OUTPUT TORQUE (IN-LBS)	719	516	429
	INPUT O.H.L.	65	248	359
	OUTPUT O.H.L.	259	471	600
<b>1150</b>	INPUT HORSEPOWER	13.77	6.89	4.07
	OUTPUT TORQUE (IN-LBS)	755	540	446
	INPUT O.H.L.	143	339	445
	OUTPUT O.H.L.	325	557	600
<b>850</b>	INPUT HORSEPOWER	10.3	5.24	3.08
	OUTPUT TORQUE (IN-LBS)	764	555	457
	INPUT O.H.L.	227	415	493
	OUTPUT O.H.L.	389	600	600
<b>690</b>	INPUT HORSEPOWER	8.36	4.33	2.54
	OUTPUT TORQUE (IN-LBS)	764	564	465
	INPUT O.H.L.	298	473	528
	OUTPUT O.H.L.	440	600	600
<b>400</b>	INPUT HORSEPOWER	4.85	2.61	1.53
	OUTPUT TORQUE (IN-LBS)	764	588	482
	INPUT O.H.L.	504	600	600
	OUTPUT O.H.L.	590	600	600
<b>300</b>	INPUT HORSEPOWER	3.64	2.00	1.17
	OUTPUT TORQUE (IN-LBS)	764	600	491
	INPUT O.H.L.	599	600	600
	OUTPUT O.H.L.	600	600	600
<b>100</b>	INPUT HORSEPOWER	1.21	0.71	0.41
	OUTPUT TORQUE (IN-LBS)	764	636	518
	INPUT O.H.L.	600	600	600
	OUTPUT O.H.L.	600	600	600

†FOR HIGHER INPUT SPEEDS CONSULT FACTORY.

‡ OVERHUNG LOAD IN POUNDS AT CENTER OF SHAFT EXTENSIONS.



# MODEL 44

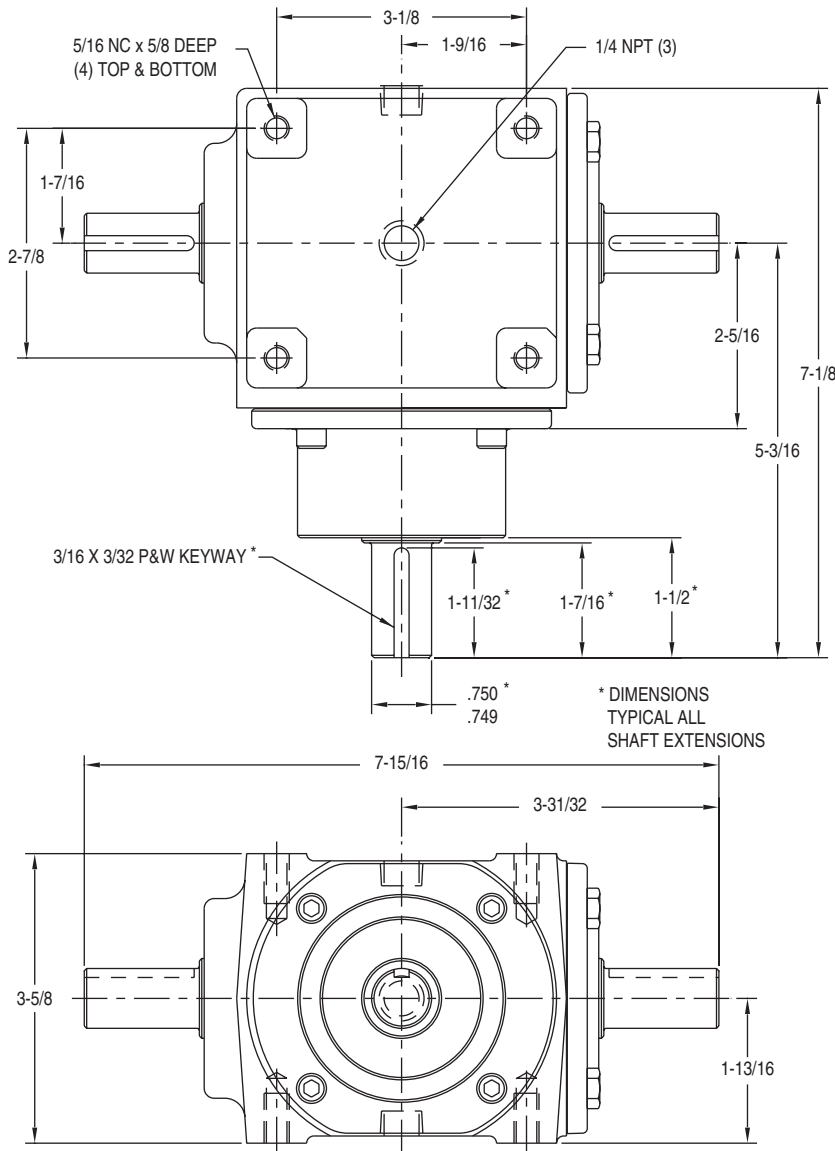

FOR LUBRICATION AND INSTALLATION INSTRUCTIONS - REFER TO SECTION R

D

RATING AND DIMENSIONS

DRY SHIPPING WEIGHTS  
 STYLES A, B, C, D, E, F .....15 lbs.

STANDARD STYLES AVAILABLE

DIMENSIONS SHOWN ARE FOR REFERENCE ONLY.  
 CERTIFIED PRINTS ARE AVAILABLE UPON REQUEST.

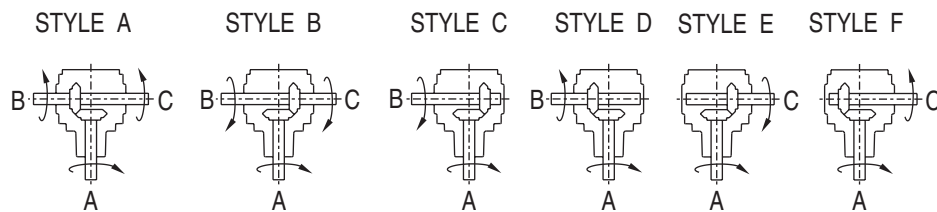

CONSULT FACTORY FOR VERTICAL SHAFT LUBRICATION RECOMMENDATIONS  
 INPUT SHAFT CAN BE ROTATED IN EITHER DIRECTION





## MODEL 11

### FEATURES

- Rugged cast iron housing designed for rigid gear and bearing support.
- Alloy shafting for greater strength.
- Tapered roller bearings for endurance and strength.
- Choice of six (6) gear ratios.
- Heavy-duty industrial seals to keep lubricant in and dirt out.
- Universal mounting assures maximum design flexibility.
- Hub City lubricant recommended. (Refer to section R)
- Available with stainless steel construction made to order.



### RATING TABLE

INPUT RPM†		REDUCTION RATIOS				INCREASER RATIOS	
		1:1	SPIRAL 1:1	1.47:1	1.8:1	1:1.47	1:1.8
2400	INPUT HORSEPOWER		21.80	8.00	7.30		
	OUTPUT TORQUE IN. LBS.		570.00	315.00	344.00		
	‡INPUT O.H.L.		65.00	248.00	223.00		
	‡OUTPUT O.H.L.		215.00	315.00	420.00		
1750	INPUT HORSEPOWER		16.00	6.10	5.40		
	OUTPUT TORQUE IN. LBS.		580.00	330.00	350.00		
	‡INPUT O.H.L.		80.00	277.00	255.00		
	‡OUTPUT O.H.L.		265.00	345.00	475.00		
1150	INPUT HORSEPOWER	12.00	11.00	4.20	3.60	5.60	5.55
	OUTPUT TORQUE IN. LBS.	660.00	600.00	340.00	355.00	205.00	169.00
	‡INPUT O.H.L.	190.00	93.00	322.00	303.00	261.00	273.00
	‡OUTPUT O.H.L.	280.00	310.00	405.00	545.00	225.00	135.00
850	INPUT HORSEPOWER	9.00	8.30	3.20	2.70	4.20	4.15
	OUTPUT TORQUE IN. LBS.	670.00	615.00	350.00	360.00	208.00	171.00
	‡INPUT O.H.L.	227.00	106.00	349.00	342.00	309.00	312.00
	‡OUTPUT O.H.L.	320.00	355.00	450.00	595.00	225.00	135.00
690	INPUT HORSEPOWER	7.60	6.80	2.60	2.20	3.50	3.40
	OUTPUT TORQUE IN. LBS.	680.00	620.00	360.00	362.00	213.00	173.00
	‡INPUT O.H.L.	248.00	139.00	388.00	371.00	348.00	341.00
	‡OUTPUT O.H.L.	360.00	395.00	495.00	575.00	225.00	135.00
400	INPUT HORSEPOWER	4.40	4.10	1.60	1.30	2.20	2.05
	OUTPUT TORQUE IN. LBS.	700.00	645.00	370.00	370.00	231.00	179.00
	‡INPUT O.H.L.	335.00	175.00	470.00	456.00	430.00	426.00
	‡OUTPUT O.H.L.	430.00	475.00	630.00	770.00	225.00	135.00
300	INPUT HORSEPOWER	3.40	3.10	1.20	1.00	1.70	1.55
	OUTPUT TORQUE IN. LBS.	710.00	650.00	380.00	393.00	238.00	181.00
	‡INPUT O.H.L.	381.00	225.00	523.00	505.00	464.00	475.00
	‡OUTPUT O.H.L.	500.00	550.00	680.00	800.00	225.00	135.00
100	INPUT HORSEPOWER	1.20	1.10	.44	.40	.68	.54
	OUTPUT TORQUE IN. LBS.	730.00	693.00	415.00	456.00	286.00	189.00
	‡INPUT O.H.L.	600.00	445.00	600.00	600.00	600.00	600.00
	‡OUTPUT O.H.L.	740.00	800.00	800.00	800.00	225.00	135.00

†FOR HIGHER INPUT SPEEDS CONSULT FACTORY.

‡ OVERHUNG LOAD IN POUNDS AT CENTER OF SHAFT EXTENSIONS.



# MODEL 11

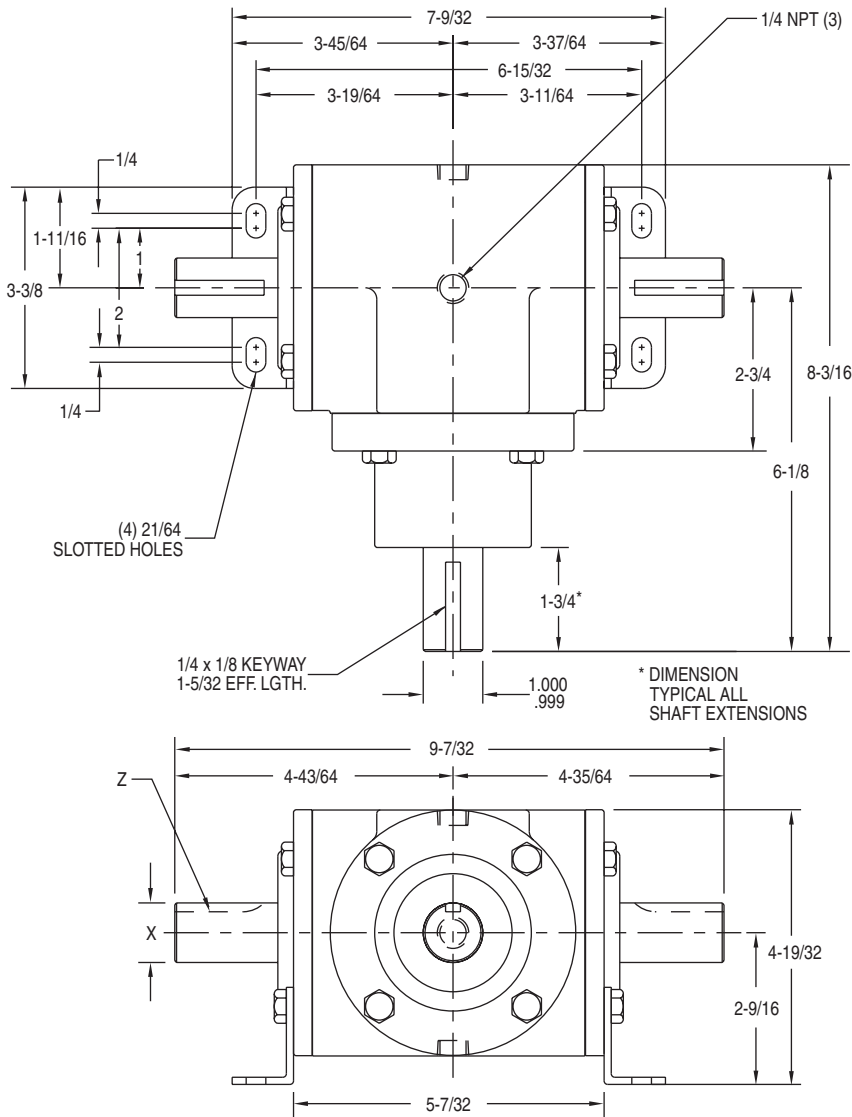

CROSS SHAFT REDUCTION RATIOS			
MODEL NO.	1:1	1:1 SPIRAL	1.47:1 1.8:1
DIA. X	$\frac{1.000}{.999}$		
KEYWAY Z	1/4 x 1/8 x 1-5/32 EFF. LGTH.		

CROSS SHAFT INCREASER RATIOS		
RATIO	1:1.47	1:1.8
DIA. X	$\frac{.750}{.749}$	$\frac{.625}{.624}$
KEYWAY Z	3/16 x 3/32 x 1-7/32 EFF. LGTH.	

FOR LUBRICATION AND INSTALLATION INSTRUCTIONS - REFER TO SECTION R

DRY SHIPPING WEIGHT  
**STYLES A, B, C, D, E, F ..... .21 lbs.**

## STANDARD STYLES AVAILABLE

DIMENSIONS SHOWN ARE FOR REFERENCE ONLY.  
 CERTIFIED PRINTS ARE AVAILABLE UPON REQUEST.

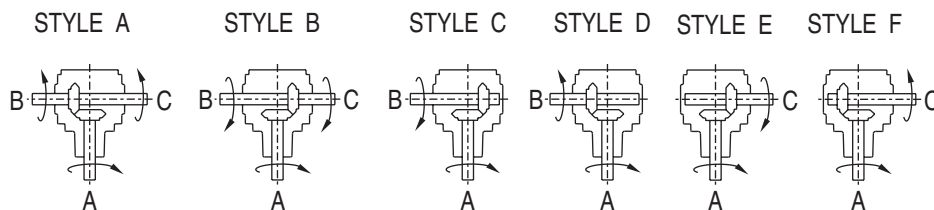

CONSULT FACTORY FOR VERTICAL SHAFT LUBRICATION RECOMMENDATIONS  
 INPUT SHAFT CAN BE ROTATED IN EITHER DIRECTION



## MODEL 150

### FEATURES

- Rugged cast iron housing designed for rigid gear and bearing support.
- Alloy shafting for greater strength.
- Tapered roller bearings for endurance and strength.
- Choice of nine (9) gear ratios.
- Heavy-duty industrial seals to keep lubricant in and dirt out.
- Universal mounting assures maximum design flexibility.
- Base and foot mounting kits available. (Refer to page D-65)
- Hub City lubricant recommended. (Refer to section R)

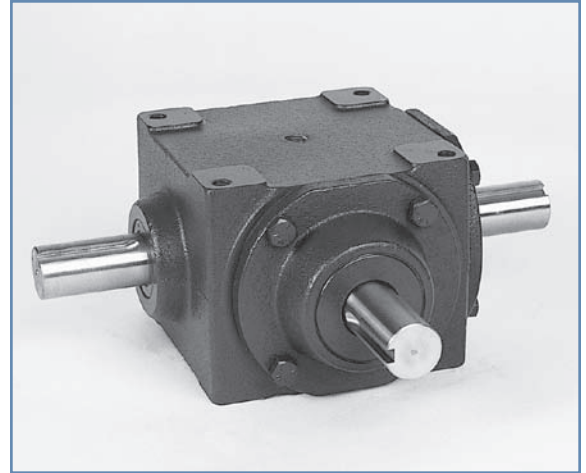

### RATING TABLE

INPUT RPM†		REDUCTION RATIOS						INCREASER RATIOS		
		1:1	SPIRAL 1:1	1.5:1	SPIRAL 1.5:1	2:1	SPIRAL 2:1	1:1.5	1:2	SPIRAL 1:1.5
3000	INPUT HORSEPOWER		26.80		28.00					
	OUTPUT TORQUE IN. LBS.		564.00		883.00					
	‡INPUT O.H.L.		40.00		20.00					
	‡OUTPUT O.H.L.		160.00		200.00					
2400	INPUT HORSEPOWER		21.80		22.70	9.00	13.65			
	OUTPUT TORQUE IN. LBS.		570.00		895.00	341.00	717.00			
	‡INPUT O.H.L.		86.00		35.00	136.00	75.00			
	‡OUTPUT O.H.L.		215.00		225.00	410.00	600.00			
1750	INPUT HORSEPOWER		16.00	9.20	16.90	6.25	10.25			24.70
	OUTPUT TORQUE IN. LBS.		580.00	500.00	911.00	442.00	736.00			593.00
	‡INPUT O.H.L.		106.00	127.00	50.00	191.00	100.00			45.00
	‡OUTPUT O.H.L.		265.00	320.00	275.00	455.00	665.00			75.00
1150	INPUT HORSEPOWER	12.00	11.00	6.20	11.30	4.25	7.00	8.20	7.20	16.70
	OUTPUT TORQUE IN. LBS.	660.00	600.00	510.00	930.00	465.00	761.00	299.00	195.00	610.00
	‡INPUT O.H.L.	112.00	124.00	197.00	75.00	240.00	125.00	168.00	237.00	60.00
	‡OUTPUT O.H.L.	280.00	310.00	380.00	375.00	525.00	750.00	135.00	135.00	90.00
850	INPUT HORSEPOWER	9.00	8.30	4.70	8.50	3.25	5.25	6.10	5.70	12.50
	OUTPUT TORQUE IN. LBS.	670.00	615.00	520.00	941.00	481.00	777.00	301.00	210.00	618.00
	‡INPUT O.H.L.	128.00	142.00	249.00	150.00	337.00	150.00	239.00	334.00	135.00
	‡OUTPUT O.H.L.	320.00	355.00	425.00	450.00	575.00	800.00	135.00	135.00	110.00
690	INPUT HORSEPOWER	7.60	6.80	3.90	6.90	2.70	4.30	5.00	4.70	10.20
	OUTPUT TORQUE IN. LBS.	680.00	620.00	530.00	950.00	494.00	788.00	304.00	215.00	621.00
	‡INPUT O.H.L.	144.00	158.00	286.00	160.00	371.00	160.00	273.00	365.00	150.00
	‡OUTPUT O.H.L.	360.00	395.00	470.00	500.00	555.00	800.00	135.00	135.00	125.00
400	INPUT HORSEPOWER	4.40	4.10	2.30	4.10	1.60	2.60	3.00	2.80	6.00
	OUTPUT TORQUE IN. LBS.	700.00	645.00	550.00	964.00	504.00	815.00	315.00	220.00	630.00
	‡INPUT O.H.L.	172.00	190.00	412.00	200.00	450.00	270.00	396.00	432.00	195.00
	‡OUTPUT O.H.L.	430.00	475.00	610.00	650.00	780.00	800.00	135.00	135.00	135.00
300	INPUT HORSEPOWER	3.40	3.10	1.80	3.10	1.25	2.00	2.30	2.20	4.60
	OUTPUT TORQUE IN. LBS.	710.00	650.00	560.00	974.00	525.00	829.00	322.00	230.00	640.00
	‡INPUT O.H.L.	203.00	220.00	456.00	225.00	496.00	370.00	469.00	451.00	237.00
	‡OUTPUT O.H.L.	500.00	550.00	655.00	750.00	800.00	800.00	135.00	135.00	135.00
100	INPUT HORSEPOWER	1.20	1.10	.65	1.05	.50	.70	.81	.75	1.60
	OUTPUT TORQUE IN. LBS.	730.00	693.00	615.00	993.00	630.00	876.00	340.00	235.00	672.00
	‡INPUT O.H.L.	363.00	332.00	600.00	350.00	600.00	600.00	600.00	600.00	325.00
	‡OUTPUT O.H.L.	740.00	800.00	800.00	800.00	800.00	800.00	135.00	135.00	135.00

†FOR HIGHER INPUT SPEEDS CONSULT FACTORY.

‡ OVERHUNG LOAD IN POUNDS AT CENTER OF SHAFT EXTENSIONS.



# MODEL 150

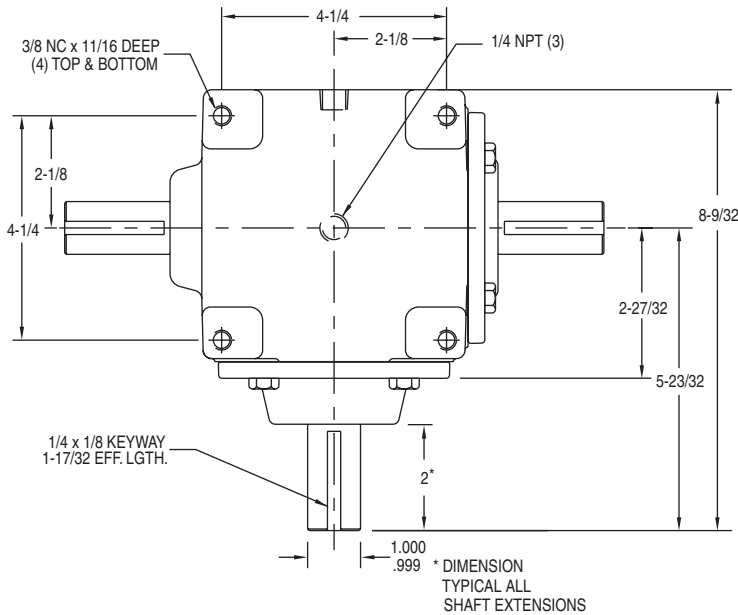

**NOTE: STYLE G & GG**

1. DIMENSIONS FOR SHAFTS A, A1, AND A2 ARE IDENTICAL FOR ALL RATIOS.
2. CENTERLINE TO END OF SHAFT DIMENSIONS WILL VARY. REQUEST CERTIFIED DIMENSIONAL PRINTS.

CROSS SHAFT REDUCTION RATIOS						
MODEL NO.	1:1	SPIRAL 1:1	1.5:1	SPIRAL 1.5:1	2:1	SPIRAL 2:1
DIA. X	1.000 .999					
KEYWAY Z	1/4 x 1/8 x 1-17/32 EFF. LGTH.					

CROSS SHAFT INCREASER RATIOS			
RATIO	1:1.5	SPIRAL 1:1.5	1:2
DIA. X	.625** .624	1.000 .999	.625** .624
KEYWAY Z	3/16 x 3/32 x 1-19/32 EFF. LGTH.	1/4 x 1/8 x 1-7/32 EFF. LGTH.	3/16 x 3/32 x 1-19/32 EFF. LGTH.

\*\*FOR STYLES A, B & GG ONLY.

**FOR LUBRICATION AND INSTALLATION INSTRUCTIONS - REFER TO SECTION R**

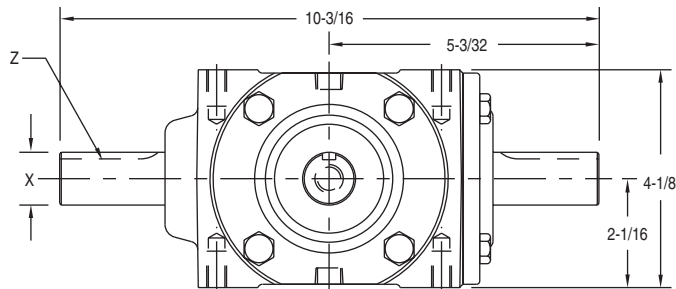

**DRY SHIPPING WEIGHTS**  
**STYLES A, B, C, D, E, F** ..... .25 lbs.  
**STYLES G** ..... .26 lbs.  
**STYLES GG** ..... .28 lbs.

**STANDARD STYLES AVAILABLE**

DIMENSIONS SHOWN ARE FOR REFERENCE ONLY.  
 CERTIFIED PRINTS ARE AVAILABLE UPON REQUEST.

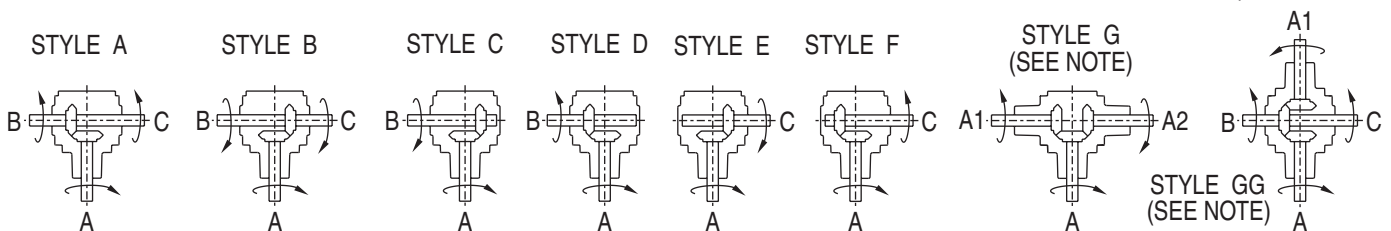

CONSULT FACTORY FOR VERTICAL SHAFT LUBRICATION RECOMMENDATIONS  
 INPUT SHAFT CAN BE ROTATED IN EITHER DIRECTION



## MODEL 165

### FEATURES

- Rugged cast iron housing designed for rigid gear and bearing support.
- Alloy shafting for greater strength.
- Tapered roller bearings for endurance and strength.
- Choice of ten (10) standard gear ratios.
- Heavy-duty industrial seals to keep lubricant in and dirt out.
- Universal mounting assures maximum design flexibility.
- Hydraulic motor mounting flanges available. (Refer to page D-67)
- Base and foot mounting kits available. (Refer to page D-65)
- Hub City lubricant recommended. (Refer to section R)
- Metric versions available. (Refer to page D-57)



### RATING TABLE

INPUT RPM†		REDUCTION RATIOS						INCREASER RATIOS				
		1:1	SPIRAL 1:1	1.5:1	SPIRAL 1.5:1	2:1	SPIRAL 2:1	3:1	1:1.5	SPIRAL 1:1.5	1:2	SPIRAL 1:2
3000	INPUT HORSEPOWER		26.87		28.00		16.75	8.70				
	OUTPUT TORQUE IN. LBS.		564.00		883.00		703.00	548.00				
	‡INPUT O.H.L.		25.00		25.00		55.00	225.00				
	‡OUTPUT O.H.L.		160.00		200.00		500.00	625.00				
2400	INPUT HORSEPOWER		21.80		22.70	9.00	13.65	7.00				
	OUTPUT TORQUE IN. LBS.		570.00		895.00	341.00	717.00	554.00				
	‡INPUT O.H.L.		54.00		50.00	330.00	85.00	275.00				
	‡OUTPUT O.H.L.		215.00		225.00	410.00	600.00	700.00				
1750	INPUT HORSEPOWER		16.00	9.20	16.90	6.25	10.25	5.20		24.70		
	OUTPUT TORQUE IN. LBS.		580.00	500.00	911.00	442.00	736.00	562.00		593.00		
	‡INPUT O.H.L.		114.00	366.00	75.00	372.00	125.00	350.00		60.00		
	‡OUTPUT O.H.L.		265.00	320.00	275.00	455.00	665.00	775.00		75.00		
1150	INPUT HORSEPOWER	17.00	11.00	6.20	11.30	4.25	7.00	3.50	8.20	16.70	7.20	13.44
	OUTPUT TORQUE IN. LBS.	930.00	600.00	510.00	930.00	465.00	761.00	571.00	299.00	610.00	195.00	368.00
	‡INPUT O.H.L.	79.00	182.00	426.00	125.00	434.00	200.00	475.00	429.00	115.00	426.00	80.00
	‡OUTPUT O.H.L.	260.00	310.00	380.00	375.00	525.00	750.00	800.00	135.00	90.00	135.00	135.00
850	INPUT HORSEPOWER	13.00	8.30	4.70	8.50	3.25	5.25	2.60	6.10	12.50	5.70	10.20
	OUTPUT TORQUE IN. LBS.	960.00	615.00	520.00	941.00	481.00	777.00	576.00	301.00	618.00	210.00	377.00
	‡INPUT O.H.L.	121.00	211.00	473.00	250.00	481.00	280.00	575.00	477.00	225.00	469.00	150.00
	‡OUTPUT O.H.L.	305.00	355.00	425.00	450.00	555.00	800.00	800.00	135.00	110.00	135.00	135.00
690	INPUT HORSEPOWER	10.60	6.80	3.90	6.90	2.70	4.30	2.10	5.00	10.20	4.70	8.40
	OUTPUT TORQUE IN. LBS.	970.00	620.00	530.00	950.00	494.00	788.00	578.00	304.00	621.00	215.00	383.00
	‡INPUT O.H.L.	156.00	243.00	508.00	325.00	517.00	345.00	600.00	512.00	290.00	500.00	210.00
	‡OUTPUT O.H.L.	345.00	395.00	470.00	500.00	575.00	800.00	800.00	135.00	125.00	135.00	135.00
400	INPUT HORSEPOWER	6.30	4.10	2.30	4.10	1.60	2.60	1.24	3.00	6.00	2.80	5.06
	OUTPUT TORQUE IN. LBS.	1000.00	645.00	550.00	964.00	504.00	815.00	586.00	315.00	630.00	220.00	398.00
	‡INPUT O.H.L.	374.00	319.00	600.00	375.00	600.00	500.00	600.00	600.00	345.00	600.00	400.00
	‡OUTPUT O.H.L.	425.00	475.00	610.00	650.00	780.00	800.00	800.00	135.00	135.00	135.00	135.00
300	INPUT HORSEPOWER	5.00	3.10	1.80	3.10	1.25	2.00	.94	2.30	4.60	2.20	3.87
	OUTPUT TORQUE IN. LBS.	1010.00	650.00	560.00	974.00	525.00	829.00	592.00	322.00	644.00	230.00	406.00
	‡INPUT O.H.L.	450.00	384.00	600.00	475.00	600.00	600.00	600.00	600.00	425.00	600.00	500.00
	‡OUTPUT O.H.L.	500.00	550.00	655.00	750.00	800.00	800.00	800.00	135.00	135.00	135.00	135.00
100	INPUT HORSEPOWER	1.65	1.10	.65	1.05	.50	.70	.32	.81	1.60	.75	1.37
	OUTPUT TORQUE IN. LBS.	1040.00	693.00	615.00	993.00	630.00	876.00	605.00	340.00	672.00	235.00	433.00
	‡INPUT O.H.L.	600.00	600.00	600.00	600.00	600.00	600.00	600.00	600.00	600.00	600.00	600.00
	‡OUTPUT O.H.L.	775.00	800.00	800.00	800.00	800.00	800.00	800.00	135.00	135.00	135.00	135.00

†FOR HIGHER INPUT SPEEDS CONSULT FACTORY.

‡OVERHUNG LOAD IN POUNDS AT CENTER OF SHAFT EXTENSIONS.



# MODEL 165

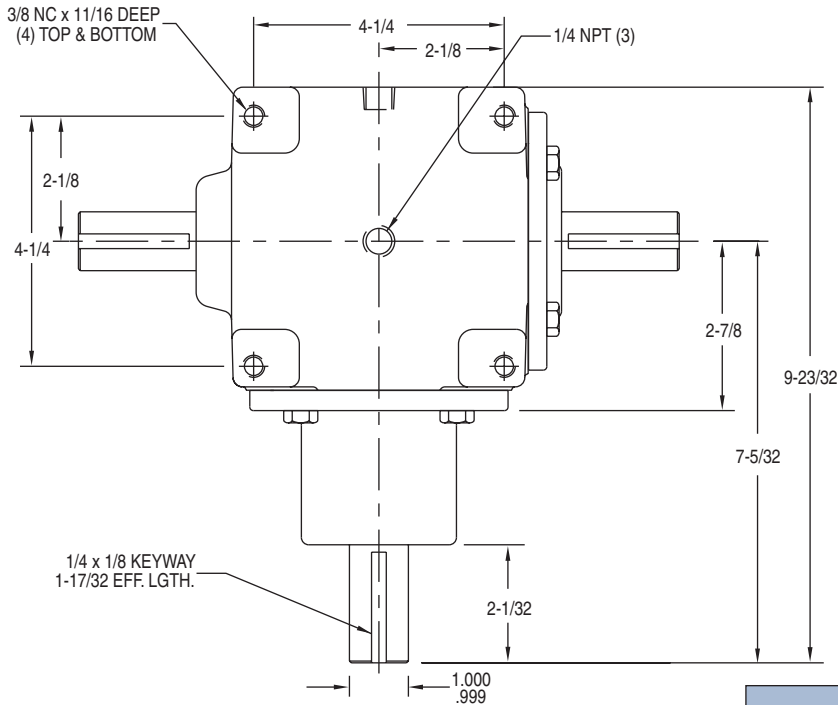

**NOTE: STYLE G & GG**

1. DIMENSIONS FOR SHAFTS A, A1, AND A2 ARE IDENTICAL FOR ALL RATIOS.
2. CENTERLINE TO END OF SHAFT DIMENSIONS WILL VARY. REQUEST CERTIFIED DIMENSIONAL PRINTS.

**FOR LUBRICATION AND INSTALLATION INSTRUCTIONS - REFER TO SECTION R**

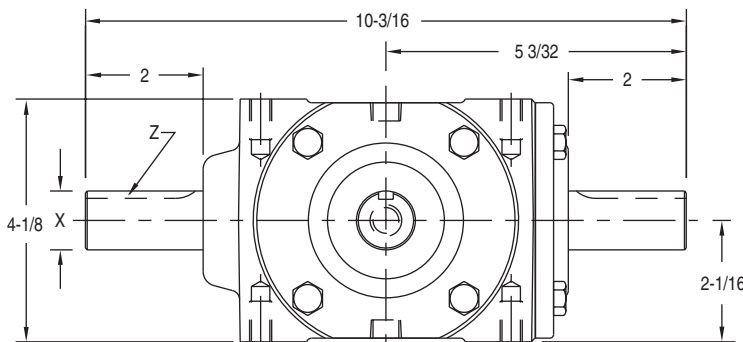

CROSS SHAFT REDUCTION RATIOS						
MODEL NO.	1:1	SPIRAL 1:1	1.5:1	SPIRAL 1.5:1	2:1	SPIRAL 2:1
DIA. X	1.000 .999					
KEYWAY Z	1/4 x 1/8 x 1-5/32 EFF. LGTH.					

CROSS SHAFT INCREASER RATIOS				
RATIO	1:1.5	SPIRAL 1:1.5	1:2	SPIRAL 1:2
DIA. X	.625** .624	1.000 .999	.625** .624	
KEYWAY Z	3/16 x 3/32 x 1-19/32 EFF. LGTH.	1/4 x 1/8 x 1-17/32 EFF. LGTH.	3/16 x 3/32 x 1-19/32 EFF. LGTH.	

\*\*FOR STYLES A, B & GG ONLY.

### DRY SHIPPING WEIGHTS

- STYLES A, B, C, D, E, F ..... .25 lbs.
- STYLES G ..... .31 lbs.
- STYLES GG ..... .36 lbs.

### STANDARD STYLES AVAILABLE

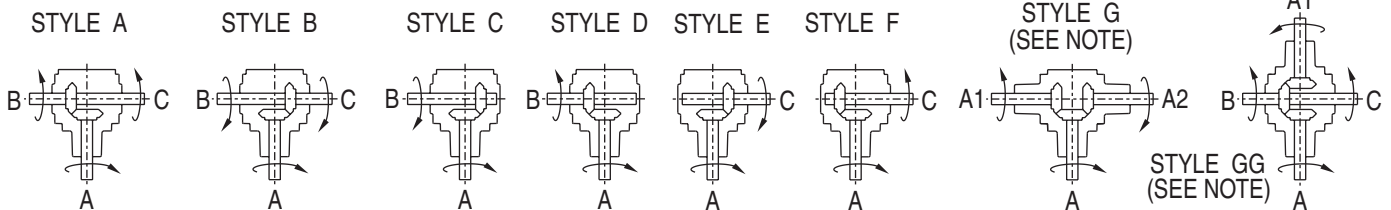

DIMENSIONS SHOWN ARE FOR REFERENCE ONLY. CERTIFIED PRINTS ARE AVAILABLE UPON REQUEST.

CONSULT FACTORY FOR VERTICAL SHAFT LUBRICATION RECOMMENDATIONS  
INPUT SHAFT CAN BE ROTATED IN EITHER DIRECTION

D RATING AND DIMENSIONS





## MODEL 175

### FEATURES

- Shaft mounted design for direct mounting on drive shaft of equipment to be driven.
- Rugged cast iron housing designed for rigid gear and bearing support.
- Alloy shafting for greater strength.
- Tapered roller bearings for endurance and strength.
- Spiral bevel gearing to assure low noise level at higher operating speeds.
- Choice of four (4) standard gear ratios.
- Heavy-duty industrial seals to keep lubricant in and dirt out.
- Universal mounting assures maximum design flexibility.
- Base and foot mounting kits available. (Refer to pages D-65)
- Hydraulic motor mounting flanges available on input only. (Refer to page D-67)
- Hub City lubricant recommended. (Refer to section R)
- Metric versions available. (Refer to page D-58)



### RATING TABLE

INPUT RPM†		REDUCTION RATIOS			
		SPIRAL 1:1	SPIRAL 1.5:1	SPIRAL 2:1	SPIRAL 3:1
3000	INPUT HORSEPOWER	26.87	28.00	16.75	8.70
	OUTPUT TORQUE IN. LBS.	564.00	883.00	703.00	548.00
	‡INPUT O.H.L.	25.00	25.00	55.00	225.00
2400	INPUT HORSEPOWER	21.80	22.70	13.65	7.00
	OUTPUT TORQUE IN. LBS.	570.00	895.00	717.00	554.00
	‡INPUT O.H.L.	54.00	50.00	85.00	275.00
1750	INPUT HORSEPOWER	16.00	16.90	10.25	5.20
	OUTPUT TORQUE IN. LBS.	580.00	911.00	736.00	562.00
	‡INPUT O.H.L.	114.00	75.00	125.00	350.00
1150	INPUT HORSEPOWER	11.00	11.30	7.00	3.50
	OUTPUT TORQUE IN. LBS.	600.00	930.00	761.00	571.00
	‡INPUT O.H.L.	182.00	125.00	200.00	475.00
850	INPUT HORSEPOWER	8.30	8.50	5.25	2.60
	OUTPUT TORQUE IN. LBS.	615.00	941.00	777.00	576.00
	‡INPUT O.H.L.	211.00	250.00	280.00	575.00
690	INPUT HORSEPOWER	6.80	6.90	4.30	2.10
	OUTPUT TORQUE IN. LBS.	620.00	950.00	788.00	578.00
	‡INPUT O.H.L.	243.00	325.00	345.00	600.00
400	INPUT HORSEPOWER	4.10	4.10	2.60	1.24
	OUTPUT TORQUE IN. LBS.	645.00	964.00	815.00	586.00
	‡INPUT O.H.L.	319.00	375.00	500.00	600.00
300	INPUT HORSEPOWER	3.10	3.10	2.00	.94
	OUTPUT TORQUE IN. LBS.	650.00	974.00	829.00	592.00
	‡INPUT O.H.L.	384.00	475.00	600.00	600.00
100	INPUT HORSEPOWER	1.10	1.05	.70	.32
	OUTPUT TORQUE IN. LBS.	693.00	993.00	876.00	605.00
	‡INPUT O.H.L.	600.00	600.00	600.00	600.00

†FOR HIGHER INPUT SPEEDS CONSULT FACTORY.

‡OVERHUNG LOAD IN POUNDS AT CENTER OF SHAFT EXTENSIONS.





**MODEL 175**

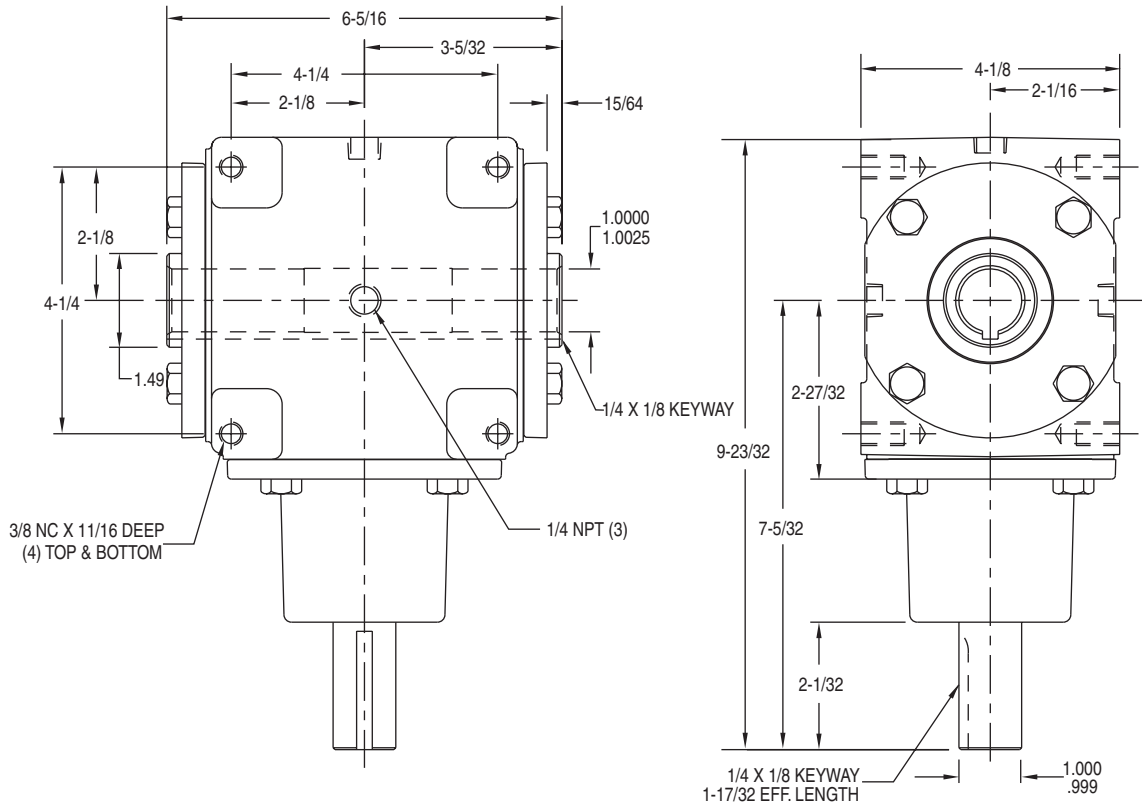

**D**  
**RATING AND DIMENSIONS**

**NOTE: STYLE GG**

1. DIMENSIONS FOR SHAFTS A, AND A1 ARE IDENTICAL FOR ALL RATIOS.
2. CENTERLINE TO END OF SHAFT DIMENSIONS WILL VARY. REQUEST CERTIFIED DIMENSIONAL PRINTS.

**DRY SHIPPING WEIGHTS**

STYLES A, B.....	.25 lbs.
STYLES GG.....	.36 lbs.

**FOR LUBRICATION AND INSTALLATION INSTRUCTIONS - REFER TO SECTION R**

**STANDARD STYLES AVAILABLE**

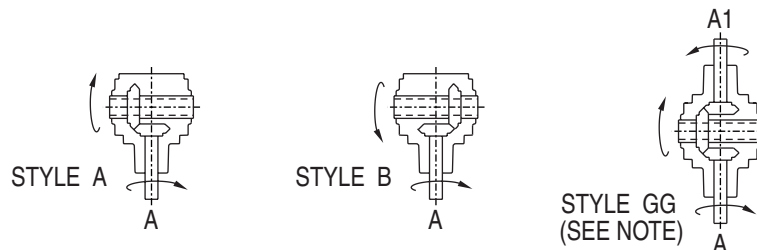

DIMENSIONS SHOWN ARE FOR REFERENCE ONLY. CERTIFIED PRINTS ARE AVAILABLE UPON REQUEST.

CONSULT FACTORY FOR VERTICAL SHAFT LUBRICATION RECOMMENDATIONS  
INPUT SHAFT CAN BE ROTATED IN EITHER DIRECTION



## MODEL 66

### FEATURES

- Rugged cast iron housing designed for rigid gear and bearing support.
- Alloy shafting for greater strength.
- Tapered roller bearings for endurance and strength.
- Choice of eleven (11) standard gear ratios.
- Heavy-duty industrial seals to keep lubricant in and dirt out.
- Universal mounting assures maximum design flexibility.
- Base, cross shaft and pinion shaft mounting kits available. (Refer to pages D-65, D-66)
- Reversing model available as factory option. (Refer to page D-66)
- Hydraulic motor mounting flanges available. (Refer to page D-67)
- Hub City lubricant recommended. (Refer to section R)
- Metric versions available. (Refer to page D-57)



### RATING TABLE

INPUT RPM†		REDUCTION RATIOS						INCREASER RATIOS				
		1:1	SPIRAL 1:1	1.5:1	SPIRAL 1.53:1	2:1	SPIRAL 2:1	SPIRAL 3:1	1:1.5	SPIRAL 1:1.53	1:2	SPIRAL 1:2
3000	INPUT HORSEPOWER				56.00		25.50	15.40				
	OUTPUT TORQUE IN. LBS.				1765.00		1072.00	951.00				
	‡INPUT O.H.L.				38.00		100.00	35.00				
	‡OUTPUT O.H.L.				80.00		725.00	100.00				
2400	INPUT HORSEPOWER		59.00		46.00		20.67	12.50		64.00		
	OUTPUT TORQUE IN. LBS.		1550.00		1810.00		1085.00	961.00		1120.00		
	‡INPUT O.H.L.		30.00		59.00		125.00	45.00		42.00		
	‡OUTPUT O.H.L.		65.00		100.00		800.00	225.00		68.00		
1750	INPUT HORSEPOWER		46.00	15.00	35.00	7.30	15.40	9.20		49.00		
	OUTPUT TORQUE IN. LBS.		1650.00	810.00	1887.00	525.00	1112.00	975.00		1180.00		
	‡INPUT O.H.L.		62.00	351.00	97.00	459.00	225.00	85.00		79.00		
	‡OUTPUT O.H.L.		100.00	300.00	140.00	330.00	900.00	350.00		140.00		
1150	INPUT HORSEPOWER	24.20	30.50	10.60	23.00	5.40	10.30	6.15		34.50		19.90
	OUTPUT TORQUE IN. LBS.	1320.00	1670.00	870.00	1930.00	591.00	1125.70	989.00		1260.00		545.00
	‡INPUT O.H.L.	126.00	109.00	446.00	133.00	521.00	400.00	100.00		102.00		325.00
	‡OUTPUT O.H.L.	190.00	160.00	340.00	190.00	380.00	1075.00	500.00		149.00		300.00
850	INPUT HORSEPOWER	19.00	24.00	8.20	18.00	4.50	7.68	4.60	11.80	26.50	7.00	15.00
	OUTPUT TORQUE IN. LBS.	1410.00	1790.00	910.00	2000.00	667.00	1139.00	998.00	580.00	1310.00	260.00	556.00
	‡INPUT O.H.L.	158.00	143.00	524.00	161.00	567.00	525.00	195.00	513.00	142.00	576.00	450.00
	‡OUTPUT O.H.L.	230.00	210.00	400.00	230.00	440.00	1080.00	750.00	520.00	178.00	400.00	350.00
690	INPUT HORSEPOWER	16.30	20.00	7.10	15.00	3.90	6.28	3.75	9.80	21.80	6.75	12.30
	OUTPUT TORQUE IN. LBS.	1480.00	1830.00	970.00	2050.00	712.00	1147.00	1009.00	600.00	1330.00	308.00	562.00
	‡INPUT O.H.L.	213.00	178.00	558.00	217.00	603.00	600.00	215.00	559.00	212.00	598.00	500.00
	‡OUTPUT O.H.L.	265.00	250.00	445.00	270.00	465.00	1080.00	800.00	679.00	307.00	400.00	400.00
300	INPUT HORSEPOWER	8.14	10.00	3.50	7.00	1.80	2.80	1.65	4.90	10.00	3.25	5.50
	OUTPUT TORQUE IN. LBS.	1700.00	2100.00	1100.00	2205.00	756.00	1177.00	1031.00	685.00	1400.00	340.00	578.00
	‡INPUT O.H.L.	418.00	312.00	744.00	421.00	806.00	900.00	550.00	750.00	370.00	793.00	875.00
	‡OUTPUT O.H.L.	425.00	420.00	645.00	425.00	715.00	1080.00	1080.00	770.00	393.00	400.00	400.00
100	INPUT HORSEPOWER	2.86	3.70	1.40	3.00	.70	.95	.55	1.80	3.50	1.30	1.88
	OUTPUT TORQUE IN. LBS.	1800.00	2330.00	1320.00	2835.00	882.00	1198.00	1056.00	775.00	1470.00	410.00	592.00
	‡INPUT O.H.L.	625.00	493.00	900.00	611.00	900.00	900.00	800.00	900.00	420.00	900.00	900.00
	‡OUTPUT O.H.L.	695.00	685.00	965.00	685.00	1080.00	1080.00	1080.00	900.00	620.00	400.00	400.00
WR <sup>2</sup> (Lb. In. <sup>2</sup> ) REFERRED TO HIGH SPEED SHAFT	STYLE											
	A, B	6.29	5.42	3.10	4.04	1.87	2.17	1.24	7.45	9.39	6.71	8.31
	C, D, E, F	6.08	5.21	3.00	3.96	1.82	2.12	1.22	6.99	9.08	6.38	7.98
	G	8.76	7.45	4.43	6.27	2.59	3.19	1.68	9.54	12.28	10.71	12.24
	GG	9.21	7.90	4.46	5.47	2.81	3.08	1.97	10.87	15.04	9.96	13.23
WR <sup>2</sup> (Lb. In. <sup>2</sup> ) REFERRED TO LOW SPEED SHAFT	A, B	6.29	5.42	6.97	9.42	7.50	8.67	11.17	3.31	4.03	1.68	2.08
	C, D, E, F	6.08	5.21	6.76	9.22	7.29	8.46	10.96	3.11	3.90	1.59	1.99
	G	8.76	7.45	9.96	14.62	10.35	12.77	15.16	4.24	5.27	2.68	3.06
	GG	9.21	7.90	10.03	12.74	11.22	12.33	17.70	4.83	6.46	2.49	3.31

†FOR HIGHER INPUT SPEEDS CONSULT FACTORY.

‡OVERHUNG LOAD IN LBS. AT CENTER OF SHAFT EXTENSIONS.



# MODEL 66

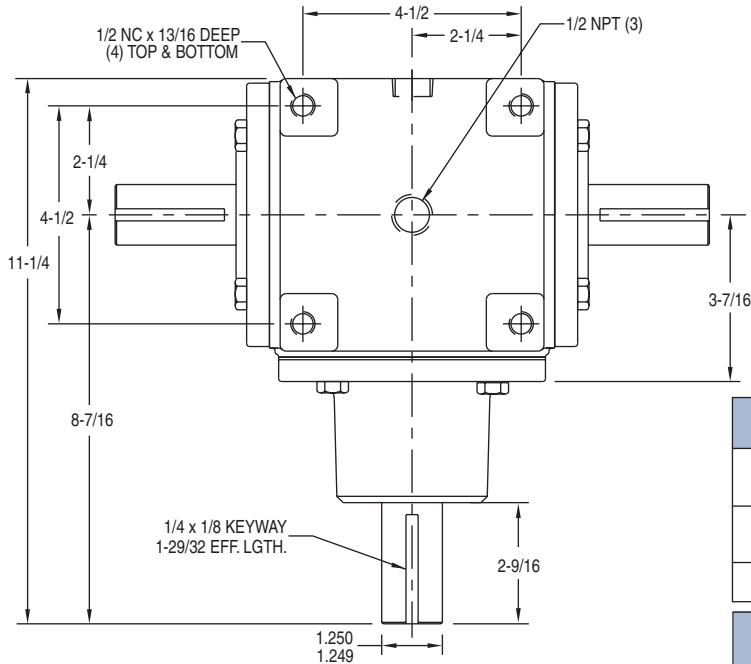

**NOTE: STYLE G & GG**

1. DIMENSIONS FOR SHAFTS A, A1, AND A2 ARE IDENTICAL FOR ALL RATIOS.
2. CENTERLINE TO END OF SHAFT DIMENSIONS WILL VARY. REQUEST CERTIFIED DIMENSIONAL PRINTS.

CROSS SHAFT REDUCTION RATIOS							
MODEL NO.	1:1	SPIRAL 1:1	1.5:1	SPIRAL 1.53:1	2:1	SPIRAL 2:1	SPIRAL 3:1
DIA. X	1.250 1.249						
KEYWAY Z	1/4 x 1/8 x 1-29/32 EFF. LGTH.						

CROSS SHAFT INCREASER RATIOS				
RATIO	1:1.5	SPIRAL 1:1.5	1:2	SPIRAL 1:2
DIA. X	1.250 1.249	1.125 1.124	1.000 .999	1.000 .999
KEYWAY Z	1/4 x 1/8 x 1-29/32 EFF. LGTH.			

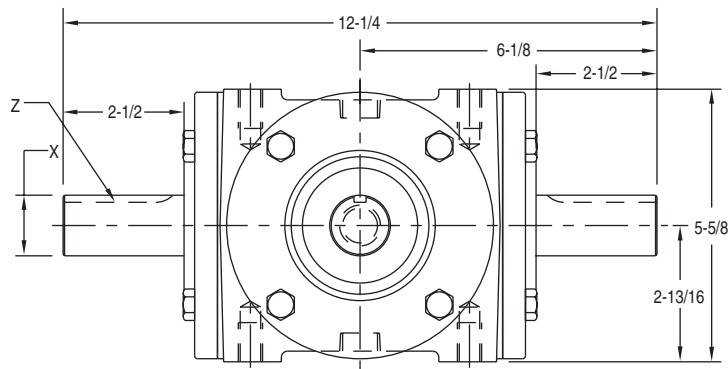

**FOR LUBRICATION AND INSTALLATION INSTRUCTIONS - REFER TO SECTION R**

**DRY SHIPPING WEIGHTS**  
 STYLES A, B, C, D, E, F ..... .43 lbs.  
 STYLES G ..... .53 lbs.  
 STYLES GG ..... .65 lbs.

**STANDARD STYLES AVAILABLE**

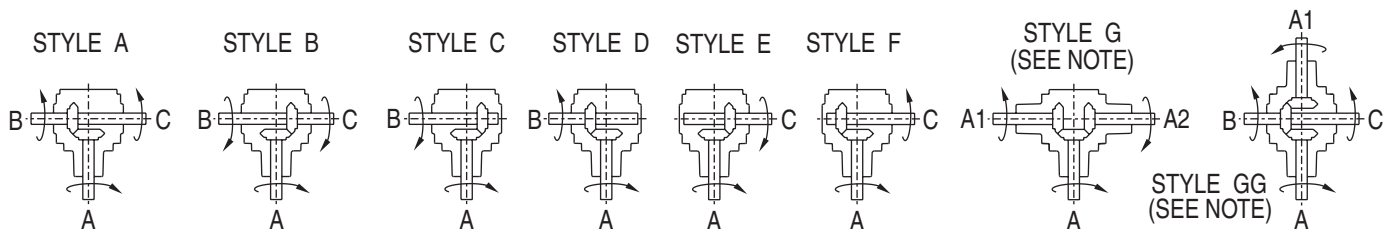

CONSULT FACTORY FOR VERTICAL SHAFT LUBRICATION RECOMMENDATIONS  
 INPUT SHAFT CAN BE ROTATED IN EITHER DIRECTION

D  
RATING AND DIMENSIONS



## MODEL 65

### FEATURES

- Shaft mounted design for direct mounting on drive shaft of equipment to be driven.
- Rugged cast iron housing designed for rigid gear and bearing support.
- Alloy shafting for greater strength.
- Tapered roller bearings for endurance and strength.
- Spiral bevel gearing to assure low noise level at higher operating speeds.
- Choice of four (4) standard gear ratios.
- Heavy-duty industrial seals to keep lubricant in and dirt out.
- Universal mounting assures maximum design flexibility.
- Base and pinion shaft mounting kits available. (Refer to pages D-65, D-66)
- Hydraulic motor mounting flanges available on input only. (Refer to page D-67)
- Hub City lubricant recommended. (Refer to section R)
- Metric versions available. (Refer to page D-58)

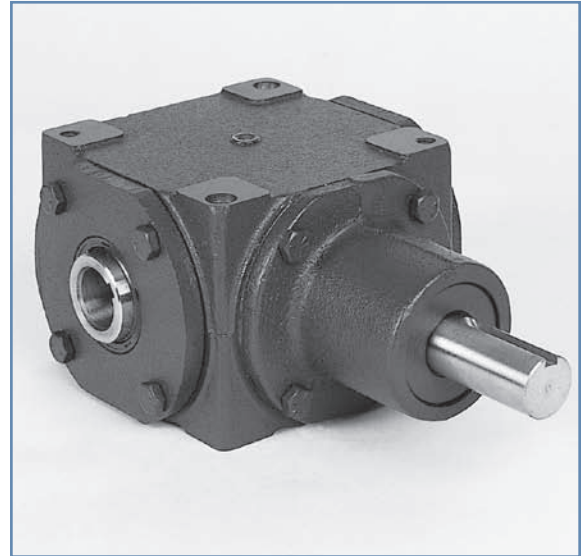

### RATING TABLE

INPUT RPM†		REDUCTION RATIOS			
		SPIRAL 1:1	SPIRAL 1.53:1	SPIRAL 2:1	SPIRAL 3:1
3000	INPUT HORSEPOWER		56.00	25.50	15.40
	OUTPUT TORQUE IN. LBS.		1765.00	1072.00	951.00
	‡INPUT O.H.L.		38.00	100.00	35.00
2400	INPUT HORSEPOWER	59.00	46.00	20.67	12.50
	OUTPUT TORQUE IN. LBS.	1550.00	1810.00	1085.00	961.00
	‡INPUT O.H.L.	30.00	59.00	125.00	45.00
1750	INPUT HORSEPOWER	46.00	35.00	15.40	9.20
	OUTPUT TORQUE IN. LBS.	1650.00	1887.00	1112.10	975.00
	‡INPUT O.H.L.	62.00	97.00	225.00	85.00
1150	INPUT HORSEPOWER	30.50	23.00	10.30	6.15
	OUTPUT TORQUE IN. LBS.	1670.00	1930.00	1125.70	989.00
	‡INPUT O.H.L.	109.00	133.00	400.00	100.00
850	INPUT HORSEPOWER	24.00	18.00	7.68	4.60
	OUTPUT TORQUE IN. LBS.	1790.00	2000.00	1139.00	998.00
	‡INPUT O.H.L.	143.00	161.00	525.00	195.00
690	INPUT HORSEPOWER	20.00	15.00	6.28	3.75
	OUTPUT TORQUE IN. LBS.	1830.00	2050.00	1147.00	1009.00
	‡INPUT O.H.L.	178.00	217.00	600.00	215.00
400	INPUT HORSEPOWER	13.00	9.20	3.71	2.20
	OUTPUT TORQUE IN. LBS.	2050.00	2170.00	1169.00	1028.00
	‡INPUT O.H.L.	254.00	283.00	875.00	450.00
300	INPUT HORSEPOWER	10.00	7.00	2.80	1.65
	OUTPUT TORQUE IN. LBS.	2100.00	2205.00	1177.00	1031.00
	‡INPUT O.H.L.	312.00	421.00	900.00	550.00
100	INPUT HORSEPOWER	3.70	3.00	.95	.55
	OUTPUT TORQUE IN. LBS.	2330.00	2835.00	1198.00	1056.00
	‡INPUT O.H.L.	493.00	611.00	900.00	800.00
WR <sup>2</sup> (Lb. In. <sup>2</sup> ) REFERRED TO HIGH SPEED SHAFT	STYLE				
	A, B GG	7.53 10.31	4.65 6.08	2.58 3.52	1.60 2.39
WR <sup>2</sup> (Lb. In. <sup>2</sup> ) REFERRED TO LOW SPEED SHAFT	A, B GG	7.53 10.31	10.88 14.22	10.31 14.09	14.43 21.50

†FOR HIGHER INPUT SPEEDS CONSULT FACTORY.

‡OVERHUNG LOAD IN POUNDS AT CENTER OF SHAFT EXTENSIONS.



# MODEL 65

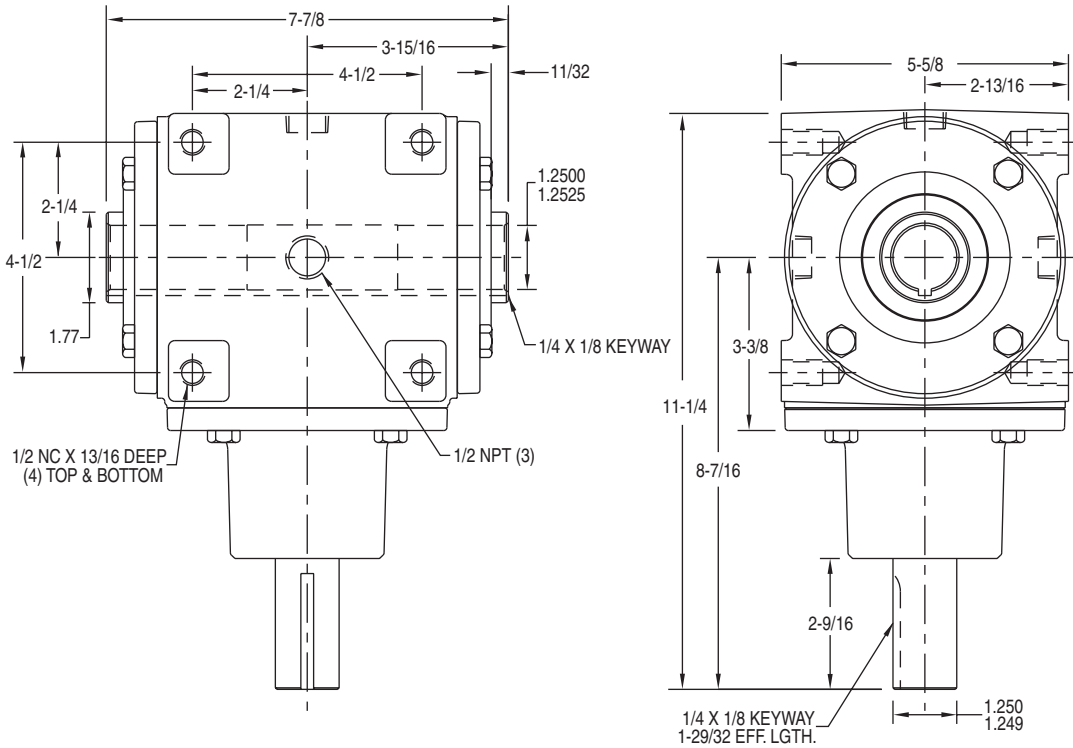

**NOTE: STYLE GG**

1. DIMENSIONS FOR SHAFTS A, AND A1 ARE IDENTICAL FOR ALL RATIOS.
2. CENTERLINE TO END OF SHAFT DIMENSIONS WILL VARY. REQUEST CERTIFIED DIMENSIONAL PRINTS.

**DRY SHIPPING WEIGHTS**

STYLES A, B.....48 lbs.  
 STYLES GG.....68 lbs.

**FOR LUBRICATION AND INSTALLATION INSTRUCTIONS - REFER TO SECTION R**

**STANDARD STYLES AVAILABLE**

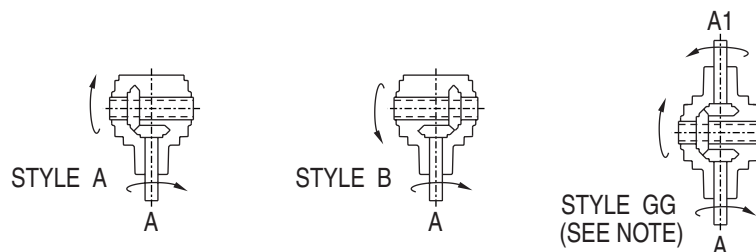

DIMENSIONS SHOWN ARE FOR REFERENCE ONLY. CERTIFIED PRINTS ARE AVAILABLE UPON REQUEST.

CONSULT FACTORY FOR VERTICAL SHAFT LUBRICATION RECOMMENDATIONS  
 INPUT SHAFT CAN BE ROTATED IN EITHER DIRECTION



## MODEL 600

### FEATURES

- Rugged cast iron housing designed for rigid gear and bearing support.
- Alloy shafting for greater strength.
- Tapered roller bearings for endurance and strength.
- Choice of six (6) standard gear ratios.
- Heavy-duty industrial seals to keep lubricant in and dirt out.
- Universal mounting assures maximum design flexibility.
- Base, cross shaft and pinion shaft mounting kits available. (Refer to pages D-65, D-66)
- Hydraulic motor mounting flanges available. (Refer to page D-67)
- Hub City lubricant recommended. (Refer to section R)



### RATING TABLE

INPUT RPM†		REDUCTION RATIOS						INCREASER RATIOS	
		1:1	SPIRAL 1:1	SPIRAL 1.2:1Δ	SPIRAL 1.29:1	1.5:1	2:1	SPIRAL 1:1.29	SPIRAL 1:1.2Δ
2400	INPUT HORSEPOWER		59.00	53.10	46.30			52.30	55.70
	OUTPUT TORQUE IN. LBS.		1550.00	1670.00	1570.00			1063.00	1221.00
	‡INPUT O.H.L.		30.00	63.00	95.00			28.00	30.00
	‡OUTPUT O.H.L.		65.00	75.00	110.00			64.00	59.00
1750	INPUT HORSEPOWER		46.00	39.80	34.70	15.00	7.30	39.30	41.90
	OUTPUT TORQUE IN. LBS.		1650.00	1720.00	1610.00	810.00	525.00	1095.00	1258.00
	‡INPUT O.H.L.		62.00	84.00	129.00	351.00	459.00	58.00	50.00
	‡OUTPUT O.H.L.		100.00	113.00	130.00	300.00	330.00	111.00	96.00
1150	INPUT HORSEPOWER	34.00	30.50	27.00	23.60	10.60	5.40	26.70	28.00
	OUTPUT TORQUE IN. LBS.	1860.00	1670.00	1770.00	1660.00	870.00	591.00	1133.00	129.80
	‡INPUT O.H.L.	84.00	109.00	136.00	199.00	446.00	521.00	102.00	97.00
	‡OUTPUT O.H.L.	220.00	160.00	178.00	190.00	340.00	380.00	178.00	148.00
850	INPUT HORSEPOWER	28.30	24.00	20.30	17.80	8.20	4.50	20.10	21.30
	OUTPUT TORQUE IN. LBS.	2090.00	1790.00	1810.00	1700.00	910.00	667.00	1158.00	1317.00
	‡INPUT O.H.L.	114.00	143.00	189.00	253.00	524.00	567.00	137.00	117.00
	‡OUTPUT O.H.L.	260.00	210.00	232.00	275.00	400.00	440.00	233.00	191.00
690	INPUT HORSEPOWER	23.90	20.00	16.70	14.60	7.10	3.90	16.60	17.66
	OUTPUT TORQUE IN. LBS.	2180.00	1830.00	1830.00	1720.00	970.00	712.00	1174.00	1344.00
	‡INPUT O.H.L.	163.00	178.00	215.00	433.00	558.00	603.00	168.00	143.00
	‡OUTPUT O.H.L.	290.00	250.00	316.00	452.00	445.00	465.00	292.00	265.00
400	INPUT HORSEPOWER	15.20	13.00	9.94	8.68	4.60	2.40	9.90	10.54
	OUTPUT TORQUE IN. LBS.	2380.00	2050.00	1880.00	1760.00	1000.00	733.00	1211.00	1385.00
	‡INPUT O.H.L.	359.00	254.00	289.00	544.00	725.00	719.00	241.00	216.00
	‡OUTPUT O.H.L.	370.00	350.00	414.00	563.00	578.00	572.00	415.00	356.00
300	INPUT HORSEPOWER	11.80	10.00	7.50	6.58	3.50	1.80	7.50	7.95
	OUTPUT TORQUE IN. LBS.	2480.00	2100.00	1890.00	1780.00	1100.00	756.00	1228.00	1392.00
	‡INPUT O.H.L.	418.00	312.00	343.00	605.00	744.00	806.00	301.00	284.00
	‡OUTPUT O.H.L.	445.00	420.00	497.00	628.00	645.00	715.00	462.00	411.00
100	INPUT HORSEPOWER	4.10	3.70	2.61	2.27	1.40	.70	2.60	2.78
	OUTPUT TORQUE IN. LBS.	2710.00	2330.00	1970.00	1850.00	1320.00	882.00	1278.00	1461.00
	‡INPUT O.H.L.	692.00	493.00	516.00	817.00	900.00	900.00	462.00	423.00
	‡OUTPUT O.H.L.	720.00	685.00	713.00	850.00	965.00	1080.00	710.00	630.00
WR <sup>2</sup> (Lb. In. <sup>2</sup> ) REFERRED TO HIGH SPEED SHAFT	STYLE								
	A, B	8.24	7.49	6.10	5.69	3.10	1.87	9.88	9.03
	C, D, E, F	7.94	7.19	5.90	5.51	3.00	1.82	9.39	8.61
	G	11.40	10.27	8.66	8.26	4.43	2.59	12.73	11.95
	GG	12.04	10.91	8.77	7.27	4.46	2.81	14.80	13.32
WR <sup>2</sup> (Lb. In. <sup>2</sup> ) REFERRED TO LOW SPEED SHAFT	A, B	8.24	7.49	8.79	9.46	6.97	7.50	5.94	6.27
	C, D, E, F	7.94	7.19	8.49	9.16	6.76	7.29	5.64	5.98
	G	11.40	10.27	12.47	13.74	9.96	10.35	7.65	8.30
	GG	12.04	10.91	12.62	12.10	10.03	11.22	8.90	9.25

†FOR HIGHER INPUT SPEEDS CONSULT FACTORY.

‡OVERHUNG LOAD IN POUNDS AT CENTER OF SHAFT EXTENSIONS.

ΔMFG. TO ORDER - CONSULT FACTORY FOR PRICE AND DELIVERY



# MODEL 600

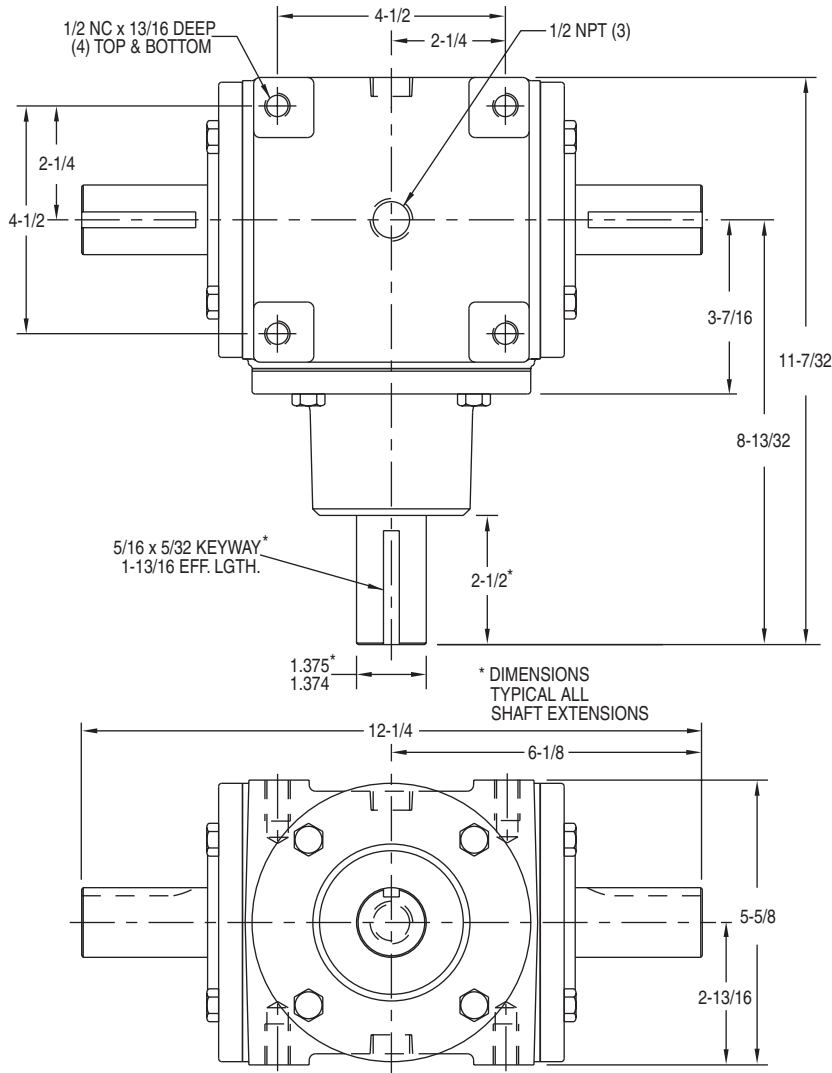

**NOTE: STYLE GG**

1. DIMENSIONS FOR SHAFTS A, AND A1 ARE IDENTICAL FOR ALL RATIOS.
2. CENTERLINE TO END OF SHAFT DIMENSIONS WILL VARY. REQUEST CERTIFIED DIMENSIONAL PRINTS.

DRY SHIPPING WEIGHTS

STYLES A, B, C, D, E, F	.48 lbs.
STYLES G	.60 lbs.
STYLES GG	.68 lbs.

FOR LUBRICATION AND INSTALLATION INSTRUCTIONS - REFER TO SECTION R

**D**  
**RATING AND DIMENSIONS**

**STANDARD STYLES AVAILABLE**

DIMENSIONS SHOWN ARE FOR REFERENCE ONLY. CERTIFIED PRINTS ARE AVAILABLE UPON REQUEST.

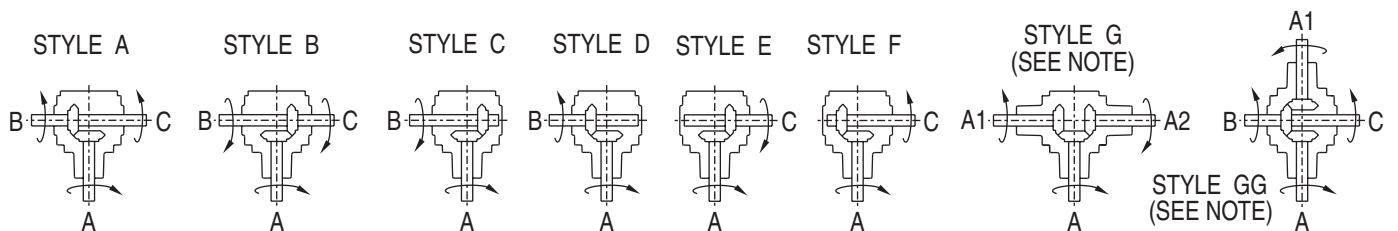

CONSULT FACTORY FOR VERTICAL SHAFT LUBRICATION RECOMMENDATIONS  
INPUT SHAFT CAN BE ROTATED IN EITHER DIRECTION





## MODEL 88

### FEATURES

- Rugged cast iron housing designed for rigid gear and bearing support.
- Alloy shafting for greater strength.
- Tapered roller bearings for endurance and strength.
- Choice of thirteen (13) standard gear ratios.
- Heavy-duty industrial seals to keep lubricant in and dirt out.
- Universal mounting assures maximum design flexibility.
- Base and pinion shaft mounting kits available.  
(Refer to pages D-65, D-66)
- Reversing model available as factory option. (Refer to page D-66)
- Hydraulic motor mounting flanges available. (Refer to page D-67)
- Hub City lubricant recommended. (Refer to section R)



### RATING TABLE

INPUT RPM†		REDUCTION RATIOS							INCREASER RATIOS					
		1:1	SPIRAL 1:1	1.5:1	SPIRAL 1.5:1	2:1	SPIRAL 2:1	3:1	SPIRAL 3:1	1:1.5	SPIRAL 1:1.5	1:2	SPIRAL 1:2	1:3*
1750	INPUT HORSEPOWER		90.00		69.00		56.00	15.00	30.69					
	OUTPUT TORQUE IN. LBS.		3240.00		3720.00		4070.00	1621.00	3316.00					
	‡INPUT O.H.L.		35.00		97.00		85.00	600.00	65.00					
	‡OUTPUT O.H.L.		320.00		475.00		225.00	760.00	400.00					
1150	INPUT HORSEPOWER		63.00	39.00	47.00	22.00	38.00	9.90	20.55		68.00		73.00	
	OUTPUT TORQUE IN. LBS.		3450.00	3200.00	3860.00	2410.00	4169.00	1629.00	3378.70		2480.00		2000.00	
	‡INPUT O.H.L.		202.00	99.00	216.00	330.00	150.00	709.00	175.00		152.00		115.00	
	‡OUTPUT O.H.L.		370.00	570.00	600.00	700.00	275.00	820.00	525.00		219.00		210.00	
850	INPUT HORSEPOWER	44.00	48.00	29.00	35.70	16.50	29.00	7.50	15.39		51.00		55.00	
	OUTPUT TORQUE IN. LBS.	3260.00	3558.00	3220.00	3970.00	2446.00	4230.00	1669.00	3423.40		2520.00		2039.00	
	‡INPUT O.H.L.	103.00	243.00	309.00	234.00	506.00	185.00	793.00	200.00		176.00		145.00	
	‡OUTPUT O.H.L.	385.00	410.00	600.00	625.00	850.00	350.00	900.00	620.00		252.00		225.00	
690	INPUT HORSEPOWER	36.50	39.50	24.00	29.50	13.80	23.00	6.50	12.59	25.00	42.50	26.00	45.00	11.40
	OUTPUT TORQUE IN. LBS.	3330.00	3607.00	3290.00	4040.00	2520.00	4267.00	1780.00	3449.90	1520.00	2585.00	1188.00	2055.00	350.00
	‡INPUT O.H.L.	234.00	308.00	432.00	329.00	602.00	235.00	843.00	240.00	290.00	247.00	373.00	175.00	892.00
	‡OUTPUT O.H.L.	450.00	475.00	685.00	710.00	950.00	400.00	1200.00	700.00	710.00	356.00	603.00	275.00	641.00
400	INPUT HORSEPOWER	21.50	23.50	14.30	17.60	8.50	13.80	3.80	7.43	18.00	26.00	15.40	27.00	7.30
	OUTPUT TORQUE IN. LBS.	3390.00	3702.00	3380.00	4160.00	2680.00	4356.00	1800.00	3512.00	1890.00	2730.00	1210.00	2127.00	380.00
	‡INPUT O.H.L.	514.00	429.00	565.00	546.00	925.00	325.00	1035.00	330.00	612.00	396.00	792.00	244.00	1062.00
	‡OUTPUT O.H.L.	565.00	590.00	910.00	930.00	1170.00	635.00	1400.00	825.00	831.00	498.00	819.00	500.00	778.00
300	INPUT HORSEPOWER	16.40	18.00	10.90	13.50	6.50	10.50	2.90	5.62	15.00	20.00	11.75	20.00	5.70
	OUTPUT TORQUE IN. LBS.	3440.00	3780.00	3435.00	4250.00	2730.00	4394.00	1827.00	3542.00	2020.00	2790.00	1235.00	2101.00	400.00
	‡INPUT O.H.L.	600.00	486.00	794.00	631.00	1038.00	365.00	1147.00	420.00	700.00	452.00	996.00	275.00	1170.00
	‡OUTPUT O.H.L.	630.00	655.00	995.00	1020.00	1250.00	875.00	1475.00	925.00	889.00	514.00	987.00	625.00	860.00
100	INPUT HORSEPOWER	5.80	6.50	3.80	4.80	2.30	3.60	1.00	1.91	5.60	7.10	4.25	7.00	2.00
	OUTPUT TORQUE IN. LBS.	3650.00	4095.00	3590.00	4440.00	2898.00	4511.00	1891.00	3611.30	2350.00	2980.00	1340.00	2206.00	420.00
	‡INPUT O.H.L.	1050.00	843.00	1400.00	1120.00	1400.00	650.00	1400.00	850.00	1235.00	608.00	1400.00	500.00	1400.00
	‡OUTPUT O.H.L.	1075.00	1100.00	1475.00	1500.00	1500.00	1200.00	1500.00	1365.00	1400.00	829.00	1400.00	900.00	1250.00
WR <sup>2</sup> (Lb. In. <sup>2</sup> ) REFERRED TO HIGH SPEED SHAFT	STYLE													
	A, B	31.46	45.53	19.28	22.28	10.72	10.50	6.59	4.67	44.31	51.04	44.56	44.27	NA
	C, D, E, F	31.08	45.15	19.12	22.11	10.63	10.40	6.55	4.63	43.48	50.22	43.09	42.81	NA
	G	45.90	66.96	30.86	35.61	17.18	17.08	11.26	7.44	57.94	67.46	54.75	54.50	72.33
	GG	46.30	67.79	26.03	31.14	13.93	14.48	8.40	6.49	71.34	85.97	71.99	71.85	NA
WR <sup>2</sup> (Lb. In. <sup>2</sup> ) REFERRED TO LOW SPEED SHAFT	A, B	31.46	45.53	43.38	50.12	42.87	41.99	59.30	42.01	19.69	22.69	11.14	11.07	NA
	C, D, E, F	31.08	45.15	43.02	49.75	42.51	41.61	58.94	41.64	19.33	22.32	10.78	10.70	NA
	G	45.90	66.96	69.45	80.13	68.73	68.31	101.36	66.93	25.75	29.98	13.69	13.62	8.04
	GG	46.30	67.79	58.56	70.06	55.73	57.92	75.60	58.41	31.71	38.21	18.00	17.96	NA

†FOR HIGHER INPUT SPEEDS CONSULT FACTORY.

\*AVAILABLE IN STYLE G ONLY

‡OVERHUNG LOAD IN LBS. AT CENTER OF SHAFT EXTENSIONS.



# MODEL 88

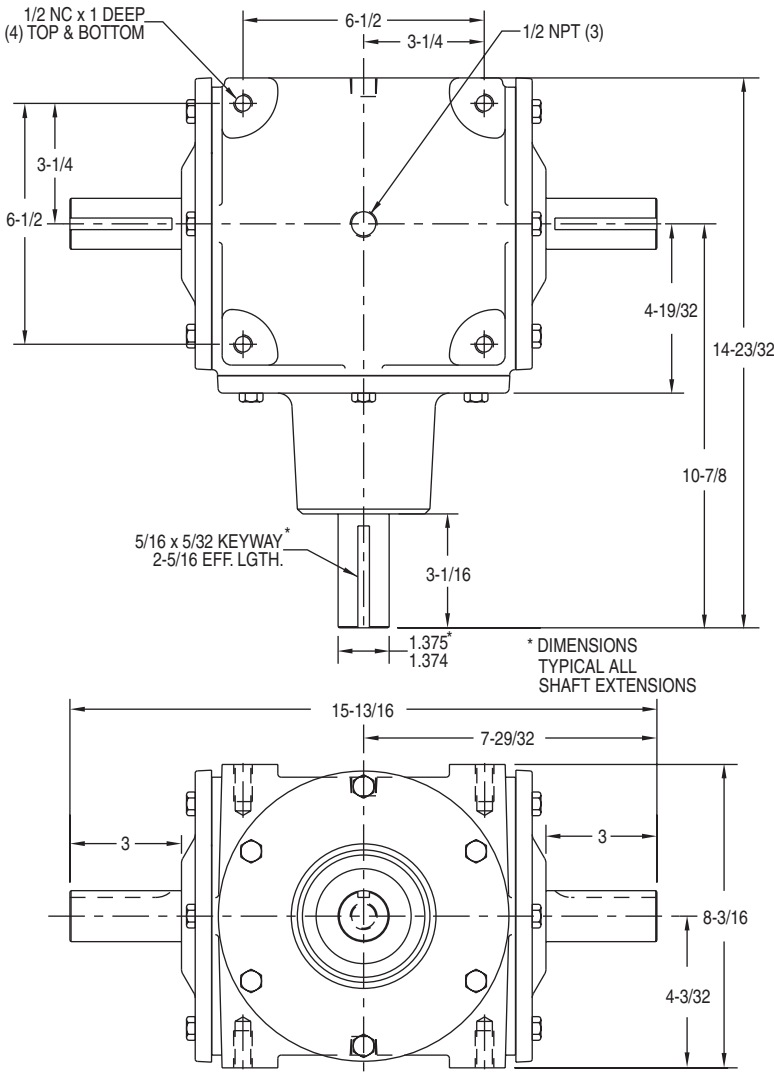

**NOTE: STYLE G & GG**

1. DIMENSIONS FOR SHAFTS A, A1, AND A2 ARE IDENTICAL FOR ALL RATIOS.
2. CENTERLINE TO END OF SHAFT DIMENSIONS WILL VARY. REQUEST CERTIFIED DIMENSIONAL PRINTS.

**FOR LUBRICATION AND INSTALLATION INSTRUCTIONS - REFER TO SECTION R**

**D**

**RATING AND DIMENSIONS**

**DRY SHIPPING WEIGHTS**

- STYLES A, B, C, D, E, F ..... .88 lbs.
- STYLES G ..... 100 lbs.
- STYLES GG ..... 112 lbs.

**STANDARD STYLES AVAILABLE**

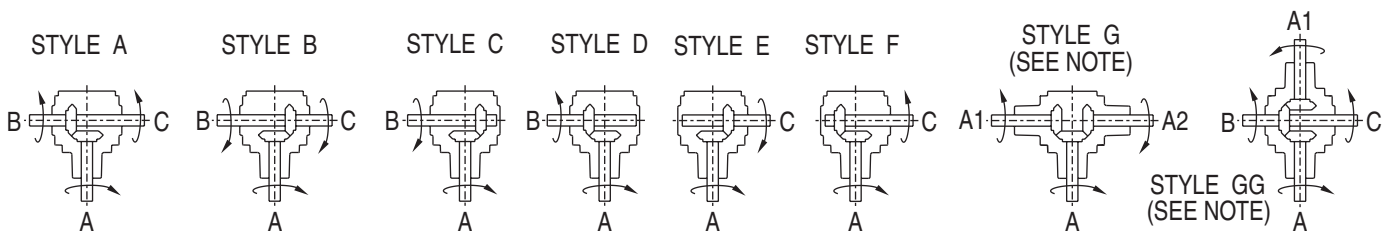

DIMENSIONS SHOWN ARE FOR REFERENCE ONLY.  
CERTIFIED PRINTS ARE AVAILABLE UPON REQUEST.

CONSULT FACTORY FOR VERTICAL SHAFT LUBRICATION RECOMMENDATIONS  
INPUT SHAFT CAN BE ROTATED IN EITHER DIRECTION



## MODELS 800-810

### FEATURES

- Rugged ductile iron housing provides maximum gear and bearing support.
- Alloy shafting for greater strength.
- Tapered roller bearings for endurance and strength.
- Choice of thirteen (13) standard gear ratios.
- Heavy-duty industrial seals to keep lubricant in and dirt out.
- Universal mounting assures maximum design flexibility.
- Base and pinion shaft mounting kits available. (Refer to pages D-65, D-66)
- Hydraulic motor mounting flanges available. (Refer to page D-67)
- Hub City lubricant recommended. (Refer to section R)
- Metric versions available. (Refer to page D-57)



### RATING TABLE

INPUT RPM†		REDUCTION RATIOS									INCREASER RATIOS					
		1:1	SPIRAL 1:1	1.21:1Δ	1.33:1	1.5:1	SPIRAL 1.5:1	1.71:1	SPIRAL 2:1	SPIRAL 3:1	1:1.21Δ	1:1.33	1:1.5	1:1.71Δ*		
1750	INPUT HORSEPOWER		132.00						69.00		56.00	30.69				
	OUTPUT TORQUE IN. LBS.		4750.00						3720.00		4070.00	3316.00				
	‡INPUT O.H.L.		140.00						75.00		65.00	100.00				
	‡OUTPUT O.H.L.		690.00						500.00		750.00	600.00				
1150	INPUT HORSEPOWER		90.00				44.00	47.00	33.00	38.00	20.55					
	OUTPUT TORQUE IN. LBS.		4930.00				3620.00	3830.00	3100.00	4169.00	3378.70					
	‡INPUT O.H.L.		308.00				1036.00	300.00	1076.00	225.00	290.00					
	‡OUTPUT O.H.L.		708.00				1280.00	1100.00	1330.00	1400.00	950.00					
850	INPUT HORSEPOWER		67.00	48.00	45.00	34.00	35.70	26.00	29.00	15.39						
	OUTPUT TORQUE IN. LBS.		4970.00	4271.00	4350.00	3780.00	3970.00	3280.00	4230.00	3423.40						
	‡INPUT O.H.L.		478.00	1062.00	1098.00	1162.00	475.00	1189.00	300.00	400.00						
	‡OUTPUT O.H.L.		870.00	1125.00	1175.00	1425.00	1550.00	1475.00	1600.00	1200.00						
690	INPUT HORSEPOWER	56.20	56.00	40.00	37.00	28.00	29.50	21.60	23.00	12.59	46.00	48.00	42.00	29.10		
	OUTPUT TORQUE IN. LBS.	5130.00	5115.00	4383.00	4400.00	3840.00	4040.00	3327.00	4267.00	3449.90	3500.00	3290.00	2560.00	1550.00		
	‡INPUT O.H.L.	1040.00	566.00	1149.00	1192.00	1257.00	625.00	1280.00	450.00	475.00	1023.00	1020.00	1069.00	1174.00		
	‡OUTPUT O.H.L.	940.00	940.00	1185.00	1235.00	1525.00	1750.00	1580.00	2050.00	1350.00	1076.00	1101.00	1066.00	1268.00		
400	INPUT HORSEPOWER	33.80	33.00	24.00	22.10	17.00	17.60	13.00	13.80	7.43	28.00	22.00	20.00	18.30		
	OUTPUT TORQUE IN. LBS.	5320.00	5200.00	4527.00	4630.00	4010.00	4160.00	3485.00	4356.00	3512.10	3780.00	3410.00	2710.00	1680.00		
	‡INPUT O.H.L.	1309.00	934.00	1425.00	1471.00	1530.00	975.00	1558.00	925.00	700.00	1284.00	1292.00	1338.00	1446.00		
	‡OUTPUT O.H.L.	1160.00	1160.00	1515.00	1640.00	1970.00	2200.00	1915.00	2200.00	1650.00	1400.00	1445.00	1387.00	1541.00		
300	INPUT HORSEPOWER	25.80	25.00	19.00	16.60	13.00	13.50	10.00	10.50	5.62	22.00	22.00	20.00	14.00		
	OUTPUT TORQUE IN. LBS.	5420.00	5250.00	4788.00	4720.00	4100.00	4250.00	3580.00	4394.00	3542.00	3860.00	3460.00	2800.00	1720.00		
	‡INPUT O.H.L.	1474.00	1155.00	1572.00	1647.00	1699.00	1200.00	1750.00	1200.00	800.00	1430.00	1456.00	1484.00	1613.00		
	‡OUTPUT O.H.L.	1340.00	1340.00	1740.00	1790.00	2125.00	2200.00	2195.00	2200.00	1800.00	1572.00	1646.00	1552.00	1750.00		
100	INPUT HORSEPOWER	9.00	9.00	6.70	6.10	4.60	4.80	3.40	3.60	1.91	8.00	7.80	6.90	5.10		
	OUTPUT TORQUE IN. LBS.	5660.00	5670.00	5067.00	5000.00	4350.00	4440.00	3642.00	4511.00	3611.30	4200.00	3690.00	2900.00	1880.00		
	‡INPUT O.H.L.	1750.00	1750.00	1750.00	1750.00	1750.00	1750.00	1750.00	1750.00	1200.00	1750.00	1750.00	1750.00	1750.00		
	‡OUTPUT O.H.L.	2080.00	2080.00	2200.00	2200.00	2200.00	2200.00	2200.00	2200.00	2200.00	1750.00	1750.00	1750.00	1750.00		
WR² (Lb. In.²) REFERRED TO HIGH SPEED SHAFT	STYLE															
	A, B	57.58	52.29	40.37	37.28	29.88	26.60	22.91	15.11	8.62	59.82	67.11	69.14	NA		
	C, D, E, F	56.64	51.17	39.73	36.75	29.46	26.18	22.58	14.88	8.51	58.44	65.45	67.02	NA		
	G	83.96	76.02	61.83	58.08	47.13	40.03	36.11	22.54	11.46	81.99	90.52	91.16	91.85		
WR² (Lb. In.²) REFERRED TO LOW SPEED SHAFT	STYLE															
	A, B	57.58	52.29	59.11	65.94	67.22	59.84	66.98	60.46	77.56	40.86	37.94	30.73	NA		
	C, D, E, F	56.64	51.17	58.16	65.00	66.28	58.90	66.04	59.52	76.62	39.92	37.00	29.79	NA		
	G	83.96	76.02	90.53	102.74	106.05	90.07	105.58	90.16	103.13	56.00	51.17	40.52	31.41		
GG	91.35	83.41	98.37	92.09	92.74	87.32	92.96	89.27	127.77	63.35	59.42	48.45	NA			

†FOR HIGHER INPUT SPEEDS CONSULT FACTORY.

‡OVERHUNG LOAD IN LBS. AT CENTER OF SHAFT EXTENSIONS.

ΔMFG. TO ORDER – CONSULT FACTORY FOR PRICE AND DELIVERY.

\*MODEL 800 ONLY



**MODELS 800-810**

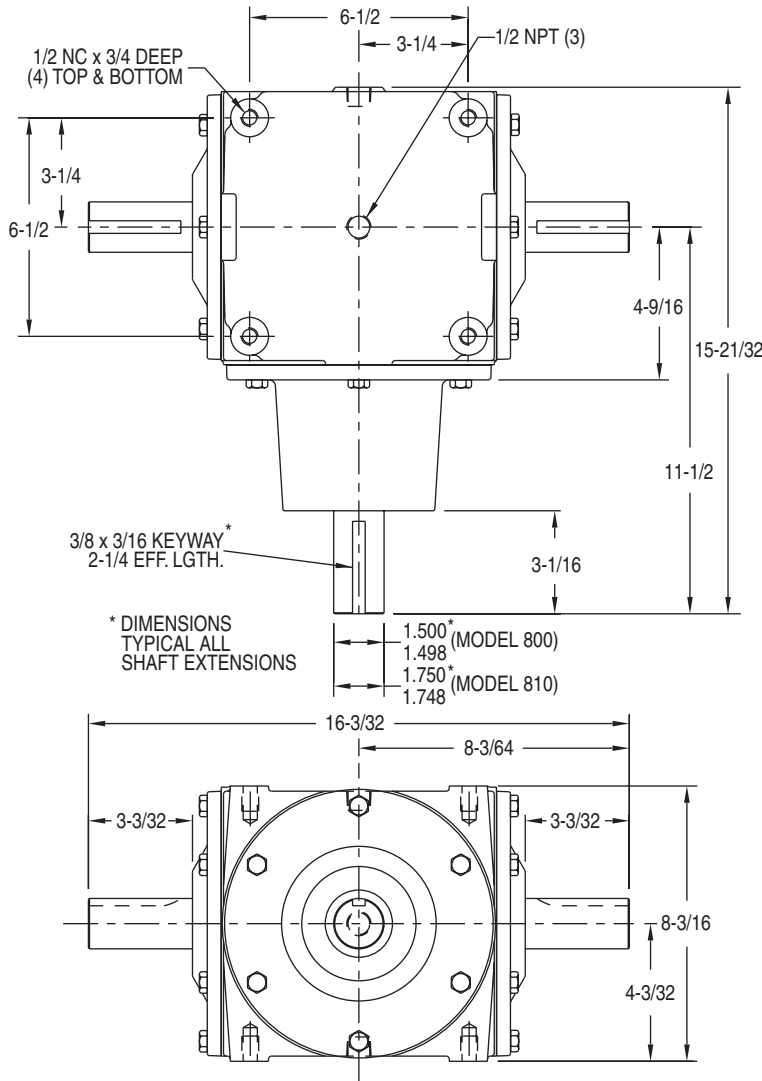

**NOTE: STYLE G & GG**

1. DIMENSIONS FOR SHAFTS A, A1, AND A2 ARE IDENTICAL FOR ALL RATIOS.
2. CENTERLINE TO END OF SHAFT DIMENSIONS WILL VARY. REQUEST CERTIFIED DIMENSIONAL PRINTS.

**FOR LUBRICATION AND INSTALLATION INSTRUCTIONS - REFER TO SECTION R**



**RATING AND DIMENSIONS**

**DRY SHIPPING WEIGHTS**

	<u>800</u>	<u>810</u>
<b>STYLES A, B, C, D, E, F</b> . . . . .	<b>90 lbs.</b>	<b>92 lbs.</b>
<b>STYLES G</b> . . . . .	<b>123 lbs.</b>	<b>125 lbs.</b>
<b>STYLES GG</b> . . . . .	<b>141 lbs.</b>	<b>145 lbs.</b>

**STANDARD STYLES AVAILABLE**

DIMENSIONS SHOWN ARE FOR REFERENCE ONLY.  
CERTIFIED PRINTS ARE AVAILABLE UPON REQUEST.

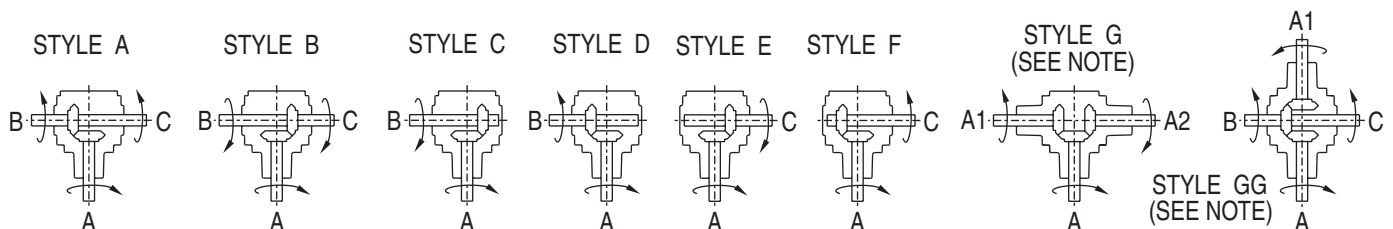

CONSULT FACTORY FOR VERTICAL SHAFT LUBRICATION RECOMMENDATIONS  
INPUT SHAFT CAN BE ROTATED IN EITHER DIRECTION



## MODEL 850

### FEATURES

- Shaft mounted design for direct mounting on drive shaft of equipment to be driven.
- Rugged cast iron housing designed for rigid gear and bearing support.
- Alloy shafting for greater strength.
- Tapered roller bearings for endurance and strength.
- Spiral bevel gearing to assure low noise level at higher operating speeds.
- Choice of four (4) standard gear ratios.
- Heavy-duty industrial seals to keep lubricant in and dirt out.
- Universal mounting assures maximum design flexibility.
- Base and pinion shaft mounting kits available. (Refer to pages D-65, D-66)
- Hydraulic motor mounting flanges available on input only. (Refer to page D-67)
- Hub City lubricant recommended. (Refer to section R)
- Metric versions available. (Refer to page D-58)

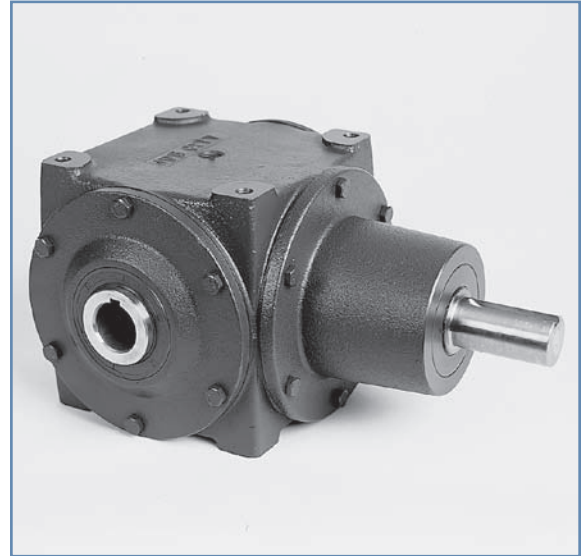

### RATING TABLE

INPUT RPM†		REDUCTION RATIOS			
		SPIRAL 1:1	SPIRAL 1.5:1	SPIRAL 2:1	SPIRAL 3:1
1750	INPUT HORSEPOWER	132.00	69.00	56.00	30.69
	OUTPUT TORQUE IN. LBS.	4750.00	3720.00	4070.00	3316.00
	‡INPUT O.H.L.	140.00	75.00	65.00	100.00
1150	INPUT HORSEPOWER	90.00	47.00	38.00	20.55
	OUTPUT TORQUE IN. LBS.	4930.00	3860.00	4169.00	3378.70
	‡INPUT O.H.L.	308.00	300.00	225.00	290.00
850	INPUT HORSEPOWER	67.00	35.70	29.00	15.39
	OUTPUT TORQUE IN. LBS.	4970.00	3970.00	4230.00	3423.40
	‡INPUT O.H.L.	478.00	475.00	300.00	400.00
690	INPUT HORSEPOWER	56.00	29.50	23.00	12.59
	OUTPUT TORQUE IN. LBS.	5115.00	4040.00	4267.00	3449.90
	‡INPUT O.H.L.	566.00	625.00	450.00	475.00
400	INPUT HORSEPOWER	33.00	17.60	13.80	7.43
	OUTPUT TORQUE IN. LBS.	5200.00	4160.00	4356.00	3512.10
	‡INPUT O.H.L.	934.00	975.00	925.00	700.00
300	INPUT HORSEPOWER	25.00	13.50	10.50	5.62
	OUTPUT TORQUE IN. LBS.	5250.00	4250.00	4394.00	3542.00
	‡INPUT O.H.L.	1155.00	1200.00	1200.00	800.00
100	INPUT HORSEPOWER	9.00	4.80	3.60	1.91
	OUTPUT TORQUE IN. LBS.	5670.00	4440.00	4511.00	3611.30
	‡INPUT O.H.L.	1750.00	1750.00	1750.00	1200.00
WR <sup>2</sup> (Lb. In. <sup>2</sup> ) REFERRED TO HIGH SPEED SHAFT	STYLE				
	A, B GG	52.90 74.95	28.14 38.65	17.12 23.93	10.06 15.36
WR <sup>2</sup> (Lb. In. <sup>2</sup> ) REFERRED TO LOW SPEED SHAFT	A, B GG	52.90 74.95	63.31 86.97	68.46 95.71	90.50 138.22

†FOR HIGHER INPUT SPEEDS CONSULT FACTORY.

‡OVERHUNG LOAD IN POUNDS AT CENTER OF SHAFT EXTENSIONS.



**MODEL 850**

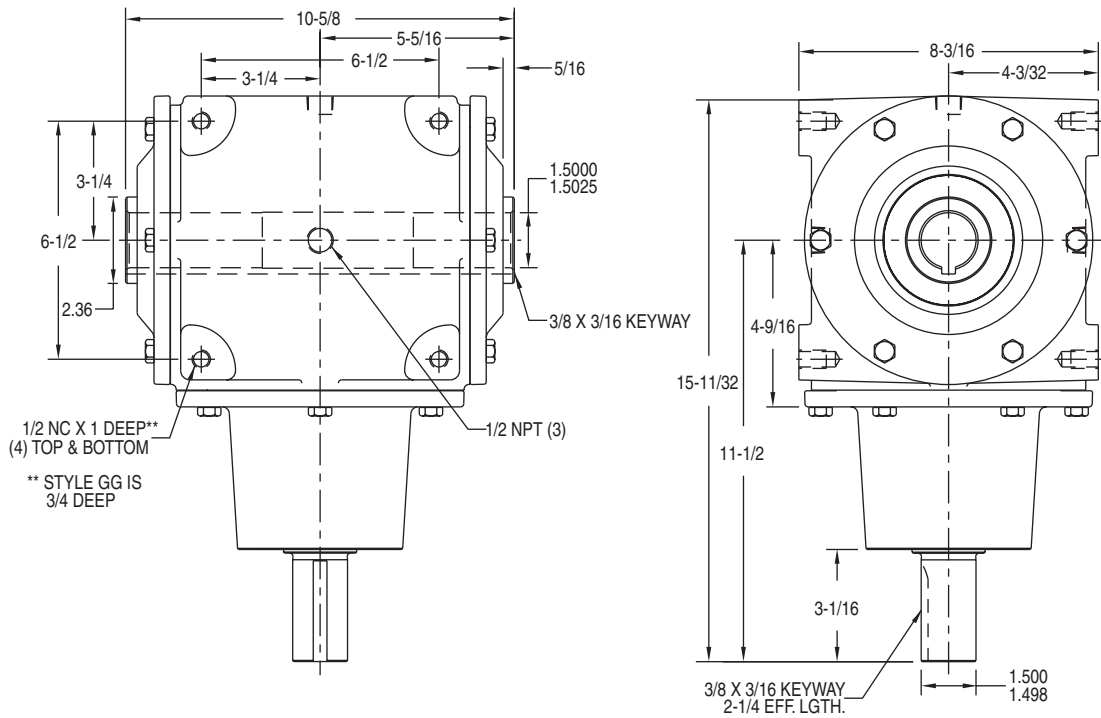

1/2 NC X 1 DEEP\*\*  
(4) TOP & BOTTOM  
\*\* STYLE GG IS  
3/4 DEEP

**NOTE: STYLE GG**

1. DIMENSIONS FOR SHAFTS A, AND A1 ARE IDENTICAL FOR ALL RATIOS.
2. CENTERLINE TO END OF SHAFT DIMENSIONS WILL VARY. REQUEST CERTIFIED DIMENSIONAL PRINTS.

**DRY SHIPPING WEIGHTS**  
 STYLES A, B ..... .88 lbs.  
 STYLES GG ..... 135 lbs.

**FOR LUBRICATION AND INSTALLATION INSTRUCTIONS - REFER TO SECTION R**

**STANDARD STYLES AVAILABLE**

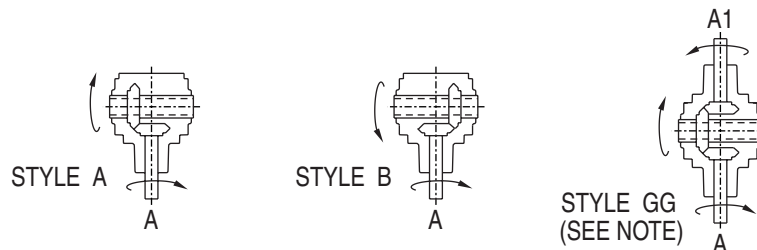

CONSULT FACTORY FOR VERTICAL SHAFT LUBRICATION RECOMMENDATIONS  
 INPUT SHAFT CAN BE ROTATED IN EITHER DIRECTION

**D**  
**RATING AND DIMENSIONS**





## MODEL 1000

### FEATURES

- Rugged ductile iron housing provides maximum gear and bearing support.
- High alloy shafting for greater strength.
- Tapered roller bearings for endurance and strength.
- Choice of seven (7) standard gear ratios.
- Heavy-duty industrial seals to keep lubricant in and dirt out.
- Universal mounting assures maximum design flexibility.
- Base mounting kits available. (Refer to pages D-65)
- Hub City lubricant recommended. (Refer to section R)



### RATING TABLE

INPUT RPM†		REDUCTION RATIOS						INCREASER RATIOS				
		1:1	1.21:1Δ	1.50:1	1.87:1	2.00:1	2.21:1	1:1.21Δ	1:1.50	1:1.87	1:2.00	1:2.21*
1000	INPUT HORSEPOWER			75.0	50.1	48.0	36.2					
	OUTPUT TORQUE IN. LBS.			7080.0	5900.0	6060.0	5900.0					
	‡INPUT O.H.L.			900.0	1100.0	950.0	1120.0					
	‡OUTPUT O.H.L.			1150.0	1350.0	1100.0	1200.0					
850	INPUT HORSEPOWER		63.0	65.0	43.0	41.7	31.0					
	OUTPUT TORQUE IN. LBS.		5606.0	7230.0	5954.0	6170.0	5059.0					
	‡INPUT O.H.L.		1090.0	1000.0	1296.0	1050.0	1311.0					
	‡OUTPUT O.H.L.		1525.0	1400.0	1875.0	1250.0	1550.0					
690	INPUT HORSEPOWER	80.0	55.0	54.0	39.0	27.7	26.0	57.0	61.4			
	OUTPUT TORQUE IN. LBS.	7304.0	6026.0	7410.0	6660.0	6470.0	5216.0	4337.0	3740.0			
	‡INPUT O.H.L.	964.0	1153.0	1100.0	1353.0	1200.0	1410.0	1088.0	1000.0			
	‡OUTPUT O.H.L.	875.0	1585.0	1500.0	1980.0	1450.0	1650.0	1252.0	1100.0			
400	INPUT HORSEPOWER	53.3	35.0	33.2	24.0	21.1	17.0	39.0	38.0	34.6	31.6	28.8
	OUTPUT TORQUE IN. LBS.	8400.0	6602.0	7840.0	7065.0	6650.0	5890.0	5119.0	3990.0	2910.0	2490.0	2060.0
	‡INPUT O.H.L.	1161.0	1418.0	1300.0	1651.0	1450.0	1684.0	1280.0	1100.0	1371.0	1250.0	1461.0
	‡OUTPUT O.H.L.	1560.0	1915.0	1700.0	2315.0	1600.0	1810.0	1392.0	1250.0	1408.0	1350.0	1343.0
300	INPUT HORSEPOWER	41.5	27.0	25.6	18.5	16.2	13.0	29.0	29.6	27.7	24.4	22.9
	OUTPUT TORQUE IN. LBS.	8720.0	6804.0	8050.0	7288.0	6810.0	6022.0	4266.0	4140.0	3110.0	2560.0	2190.0
	‡INPUT O.H.L.	1323.0	1597.0	1350.0	1842.0	1600.0	1877.0	1312.0	1200.0	1526.0	1400.0	1616.0
	‡OUTPUT O.H.L.	1740.0	2140.0	1850.0	2595.0	1800.0	1950.0	1420.0	1300.0	1567.0	1500.0	1490.0
100	INPUT HORSEPOWER	17.0	11.0	9.2	7.0	5.8	4.8	13.0	10.9	9.8	9.0	8.5
	OUTPUT TORQUE IN. LBS.	10700.0	8319.0	8740.0	8005.0	7340.0	6646.0	6825.0	4570.0	3300.0	2830.0	2430.0
	‡INPUT O.H.L.	2018.0	2360.0	2000.0	2300.0	2000.0	2500.0	1957.0	1750.0	2360.0	2000.0	2450.0
	‡OUTPUT O.H.L.	2480.0	2960.0	2200.0	3540.0	2200.0	2500.0	1981.0	1900.0	2500.0	2200.0	2197.0
WR <sup>2</sup> (Lb. In. <sup>2</sup> ) REFERRED TO HIGH SPEED SHAFT	STYLE											
	A, B	140.6	75.4		43.8		35.9	75.9		51.3		
	C, D, E, F	139.6	74.7	Consult Factory	42.6	Consult Factory	35.7	74.9	Consult Factory	50.3	Consult Factory	
	GG	187.5	115.4		74.9		58.5	107.9		54.5	Consult Factory	48.5
WR <sup>2</sup> (Lb. In. <sup>2</sup> ) REFERRED TO LOW SPEED SHAFT	A, B	140.6	108.6		153.3		173.9	109.3		179.2		
	C, D, E, F	139.6	107.6	Consult Factory	152.3	Consult Factory	172.9	107.9	Consult Factory	177.8	Consult Factory	
	G	187.5	166.2		263.2		283.1	155.5	Consult Factory	194.0	Consult Factory	234.5
	GG	210.2	156.9		195.2		235.9	168.3		289.2		

†FOR HIGHER INPUT SPEEDS CONSULT FACTORY.  
‡OVERHUNG LOAD IN LBS. AT CENTER OF SHAFT EXTENSIONS.

ΔMFG. TO ORDER – CONSULT FACTORY FOR PRICE AND DELIVERY.  
\*AVAILABLE IN STYLE G ONLY.





# MODEL 1000

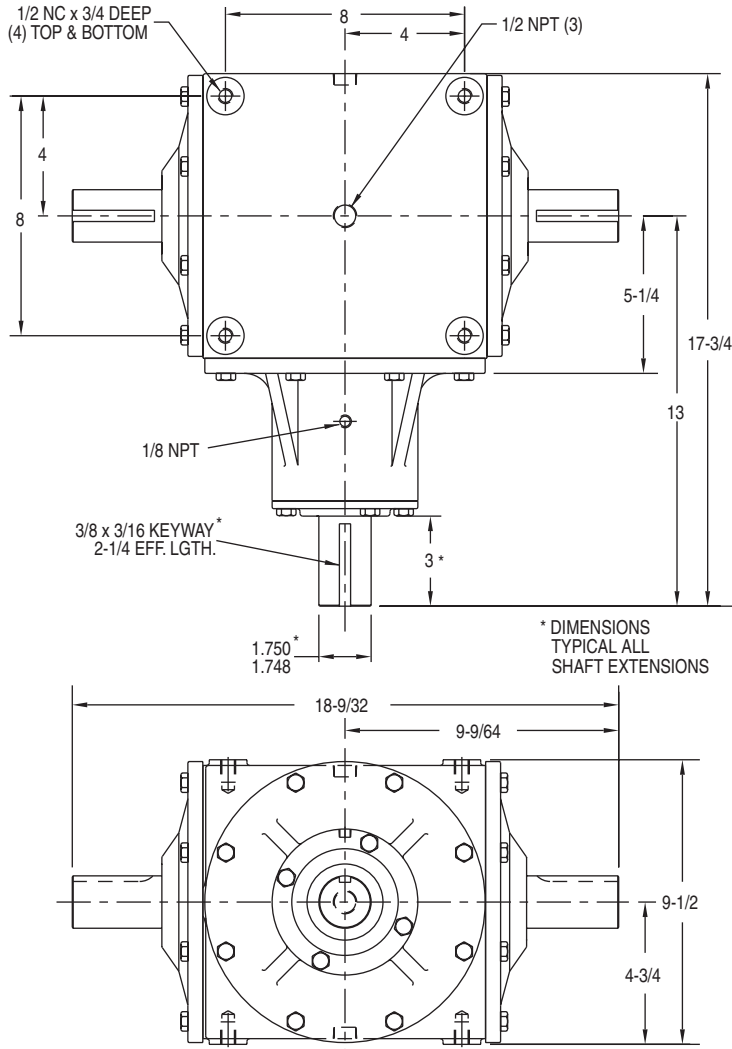

**NOTE: STYLE G & GG**

1. DIMENSIONS FOR SHAFTS A, A1, AND A2 ARE IDENTICAL FOR ALL RATIOS.
2. CENTERLINE TO END OF SHAFT DIMENSIONS WILL VARY. REQUEST CERTIFIED DIMENSIONAL PRINTS.

**FOR LUBRICATION AND INSTALLATION INSTRUCTIONS - REFER TO SECTION R**

**D**

**RATING AND DIMENSIONS**

**DRY SHIPPING WEIGHTS**

- STYLES A, B, C, D, E, F ..... 150 lbs.
- STYLES G ..... 160 lbs.
- STYLES GG ..... 175 lbs.

**STANDARD STYLES AVAILABLE**

DIMENSIONS SHOWN ARE FOR REFERENCE ONLY.  
CERTIFIED PRINTS ARE AVAILABLE UPON REQUEST.

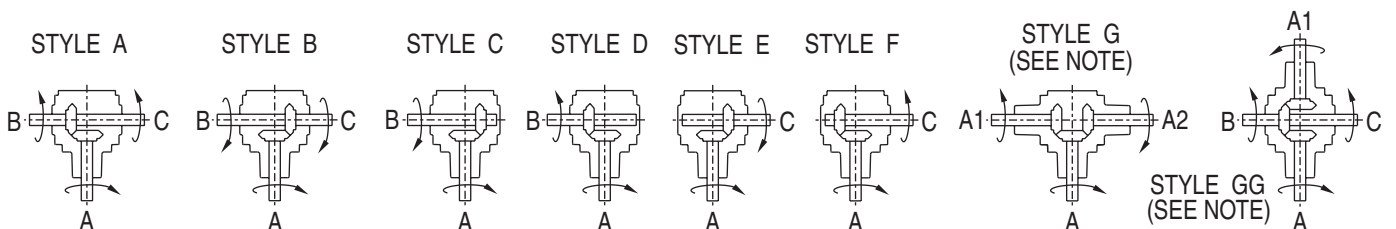

CONSULT FACTORY FOR VERTICAL SHAFT LUBRICATION RECOMMENDATIONS  
INPUT SHAFT CAN BE ROTATED IN EITHER DIRECTION



## MODEL 1010

### FEATURES

- Rugged ductile iron housing provides maximum gear and bearing support.
- High alloy shafting for greater strength.
- Tapered roller bearings for endurance and strength.
- Spiral bevel gearing to assure low noise level at higher operating speeds.
- Choice of six (6) standard gear ratios.
- Heavy-duty industrial seals to keep lubricant in and dirt out.
- Universal mounting assures maximum design flexibility.
- Base mounting kits available. (Refer to pages D-65)
- Hub City lubricant recommended. (Refer to section R)
- Hub City "Counter Flow" bearing lubrication system.
- Metric versions available. (Refer to page D-57)



### RATING TABLE

INPUT RPM†		REDUCTION RATIOS					INCREASER RATIO
		SPIRAL 1:1	SPIRAL 1.3:1Δ	SPIRAL 1.5:1	SPIRAL 2:1	SPIRAL 3:1Δ	1:1.5
1750	INPUT HORSEPOWER	251.00	195.00	173.00	123.90	55.80	232.40
	OUTPUT TORQUE IN. LBS.	9039.00	9360.00	9350.00	8924.00	6028.00	5577.00
	‡INPUT O.H.L.	820.00	400.00	100.00	130.00	140.00	764.00
	‡OUTPUT O.H.L.	1398.00	1500.00	2100.00	2100.00	2100.00	681.00
1150	INPUT HORSEPOWER	173.00	133.50	118.20	84.40	37.70	159.40
	OUTPUT TORQUE IN. LBS.	9481.00	9750.00	9717.00	9251.00	6198.00	5821.00
	‡INPUT O.H.L.	1178.00	500.00	385.00	433.00	455.00	1134.00
	‡OUTPUT O.H.L.	2100.00	2100.00	2100.00	2100.00	2100.00	1385.00
850	INPUT HORSEPOWER	131.50	101.20	89.50	63.80	28.40	121.10
	OUTPUT TORQUE IN. LBS.	9750.00	10,002.00	9954.00	9461.00	6317.00	5985.00
	‡INPUT O.H.L.	1493.00	750.00	665.00	748.00	780.00	1449.00
	‡OUTPUT O.H.L.	2100.00	2100.00	2100.00	2100.00	2100.00	1958.00
690	INPUT HORSEPOWER	108.60	83.50	73.80	52.50	23.30	100.10
	OUTPUT TORQUE IN. LBS.	9920.00	10,167.00	10,111.00	9591.00	6384.00	6091.00
	‡INPUT O.H.L.	1737.00	1100.00	902.00	994.00	1000.00	1674.00
	‡OUTPUT O.H.L.	2100.00	2100.00	2100.00	2100.00	2100.00	2100.00
400	INPUT HORSEPOWER	65.60	49.90	44.30	31.40	13.90	60.40
	OUTPUT TORQUE IN. LBS.	10,320.00	10,480.00	10,470.00	9895.00	6570.00	6341.00
	‡INPUT O.H.L.	1850.00	1700.00	1635.00	1745.00	1850.00	1850.00
	‡OUTPUT O.H.L.	2100.00	2100.00	2100.00	2100.00	2100.00	2100.00
300	INPUT HORSEPOWER	50.20	38.10	33.70	23.80	10.60	46.10
	OUTPUT TORQUE IN. LBS.	10,546.00	10,670.00	10,620.00	10,000.00	6680.00	6606.00
	‡INPUT O.H.L.	1850.00	1850.00	1850.00	1850.00	1850.00	1850.00
	‡OUTPUT O.H.L.	2100.00	2100.00	2100.00	2100.00	2100.00	2100.00
100	INPUT HORSEPOWER	18.50	13.10	11.80	8.30	3.70	16.20
	OUTPUT TORQUE IN. LBS.	11,659.00	11,005.00	11,130.00	10,462.00	6995.00	6815.00
	‡INPUT O.H.L.	1850.00	1850.00	1850.00	1850.00	1850.00	1850.00
	‡OUTPUT O.H.L.	2100.00	2100.00	2100.00	2100.00	2100.00	2100.00
WR <sup>2</sup> (Lb. In. <sup>2</sup> ) REFERRED TO HIGH SPEED SHAFT	STYLE						
	A, B	281	96	105	68	31	111
	C, D, E, F	279	95	104	67	30	105
	G	412	154	156	100	41	159
	GG	419	124	152	101	48	168
WR <sup>2</sup> (Lb. In. <sup>2</sup> ) REFERRED TO LOW SPEED SHAFT	A, B	281	170	235	272	274	250
	C, D, E, F	279	168	233	270	272	236
	G	412	273	351	398	367	357
	GG	419	220	342	405	436	379

†FOR HIGHER INPUT SPEEDS CONSULT FACTORY.

‡OVERHUNG LOAD IN LBS. AT CENTER OF SHAFT EXTENSIONS.  
ΔMFG. TO ORDER - CONSULT FACTORY FOR PRICE AND DELIVERY



# MODEL 1010

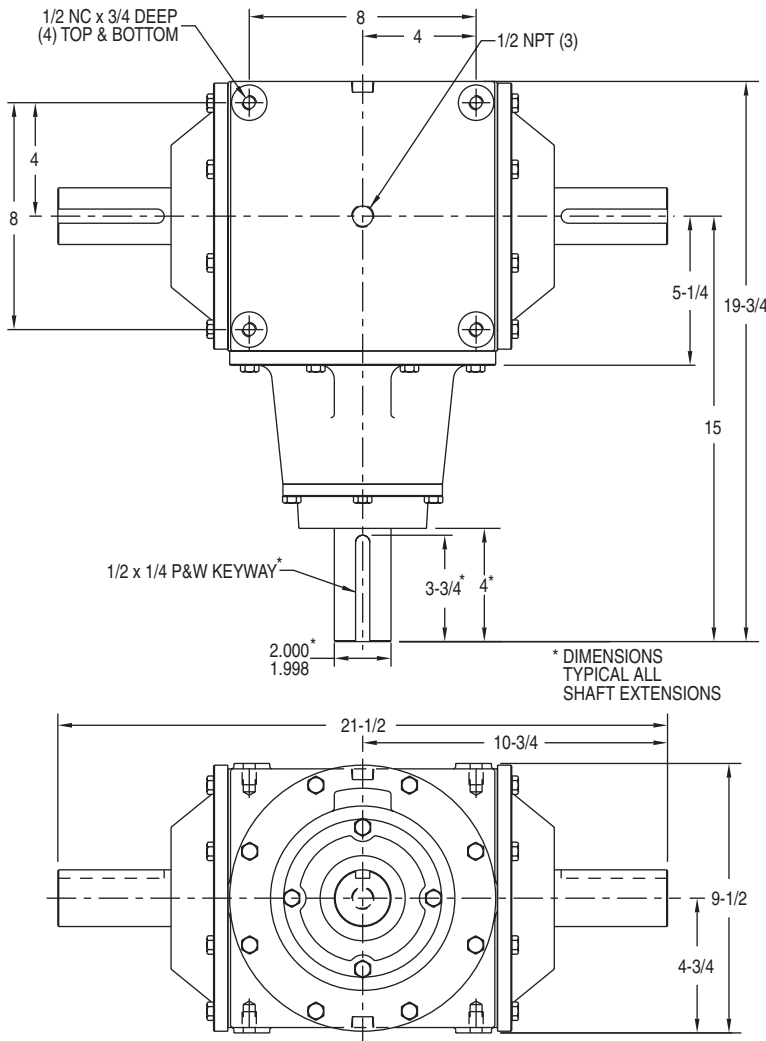

### ATTENTION

FOR CONTINUOUS DUTY APPLICATIONS ABOVE 1000 RPM THE CAPACITY OF THESE UNITS MAY BE LIMITED BY THERMAL CONSIDERATIONS. IN THESE CASES OIL CIRCULATION AND OIL COOLING MAY BE REQUIRED. CONSULT THE FACTORY FOR APPLICATION ASSISTANCE.

### NOTE: STYLE G & GG

1. DIMENSIONS FOR SHAFTS A, A1, AND A2 ARE IDENTICAL FOR ALL RATIOS.
2. CENTERLINE TO END OF SHAFT DIMENSIONS WILL VARY. REQUEST CERTIFIED DIMENSIONAL PRINTS.

FOR LUBRICATION AND INSTALLATION INSTRUCTIONS - REFER TO SECTION R

D

RATING AND DIMENSIONS

### DRY SHIPPING WEIGHTS

- STYLES A, B, C, D, E, F ..... 195 lbs.
- STYLES G ..... 195 lbs.
- STYLES GG ..... 225 lbs.

### STANDARD STYLES AVAILABLE

DIMENSIONS SHOWN ARE FOR REFERENCE ONLY. CERTIFIED PRINTS ARE AVAILABLE UPON REQUEST.

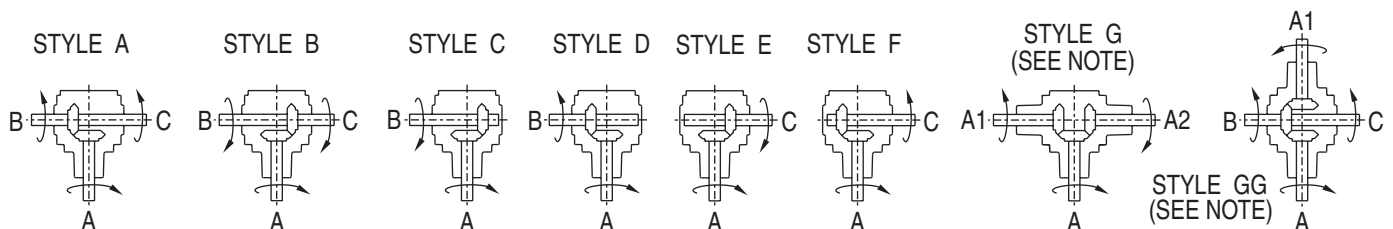

CONSULT FACTORY FOR VERTICAL SHAFT LUBRICATION RECOMMENDATIONS  
INPUT SHAFT CAN BE ROTATED IN EITHER DIRECTION



## MODEL 1050

### FEATURES

- Shaft mounted design for direct mounting on drive shaft of equipment to be driven.
- Rugged ductile iron housing provides maximum gear and bearing support.
- High alloy shafting for greater strength.
- Tapered roller bearings for endurance and strength.
- Spiral bevel gearing to assure low noise level at higher operating speeds.
- Choice of five (5) standard gear ratios.
- Heavy-duty industrial seals to keep lubricant in and dirt out.
- Hub City lubricant recommended. (Refer to section R)
- Hub City "Counter Flow" bearing lubrication system.
- Metric versions available. (Refer to page D-58)



### RATING TABLE

INPUT RPM†		REDUCTION RATIOS				
		SPIRAL 1:1	SPIRAL 1.3:1Δ	SPIRAL 1.5:1	SPIRAL 3:1Δ	SPIRAL 2:1
1750	INPUT HORSEPOWER	251.00	195.00	173.10	55.80	123.90
	OUTPUT TORQUE IN. LBS.	9039.00	9360.00	9350.00	6028.00	8924.00
	‡INPUT O.H.L.	820.00	400.00	100.00	140.00	130.00
1150	INPUT HORSEPOWER	173.00	133.50	118.20	37.70	84.40
	OUTPUT TORQUE IN. LBS.	9481.00	9750.00	9717.00	6198.00	9251.00
	‡INPUT O.H.L.	1178.00	500.00	385.00	455.00	433.00
850	INPUT HORSEPOWER	131.50	101.20	89.50	28.40	63.80
	OUTPUT TORQUE IN. LBS.	9750.00	10,002.00	9954.00	6317.00	9461.00
	‡INPUT O.H.L.	1493.00	750.00	665.00	780.00	748.00
690	INPUT HORSEPOWER	108.60	83.50	73.80	23.30	52.50
	OUTPUT TORQUE IN. LBS.	9920.00	10,167.00	10,111.00	6384.00	9591.00
	‡INPUT O.H.L.	1737.00	1100.00	902.00	1000.00	994.00
400	INPUT HORSEPOWER	65.60	49.90	44.30	13.90	31.40
	OUTPUT TORQUE IN. LBS.	10,320.00	10,480.00	10,470.00	6570.00	9895.00
	‡INPUT O.H.L.	1850.00	1700.00	1635.00	1850.00	1745.00
300	INPUT HORSEPOWER	50.20	38.10	33.70	10.60	23.80
	OUTPUT TORQUE IN. LBS.	10,546.00	10,670.00	10,620.00	6680.00	10,000.00
	‡INPUT O.H.L.	1850.00	1850.00	1850.00	1850.00	1850.00
100	INPUT HORSEPOWER	18.50	13.10	11.80	3.70	8.30
	OUTPUT TORQUE IN. LBS.	11,659.00	11,005.00	11,130.00	6995.00	10,462.00
	‡INPUT O.H.L.	1850.00	1850.00	1850.00	1850.00	1850.00
WR <sup>2</sup> (Lb. In. <sup>2</sup> ) REFERRED TO HIGH SPEED SHAFT	STYLE					
	A, B	249.8	104.4	108.5	32.2	65.9
	GG	388.4	132.6	154.5	44.3	96.8
WR <sup>2</sup> (Lb. In. <sup>2</sup> ) REFERRED TO LOW SPEED SHAFT	A, B	249.8	184.7	244.1	289.5	263.7
	GG	388.4	234.5	347.6	398.7	387.1

†FOR HIGHER INPUT SPEEDS CONSULT FACTORY.

ΔMFG. TO ORDER - CONSULT FACTORY FOR PRICE AND DELIVERY



**MODEL 1050**

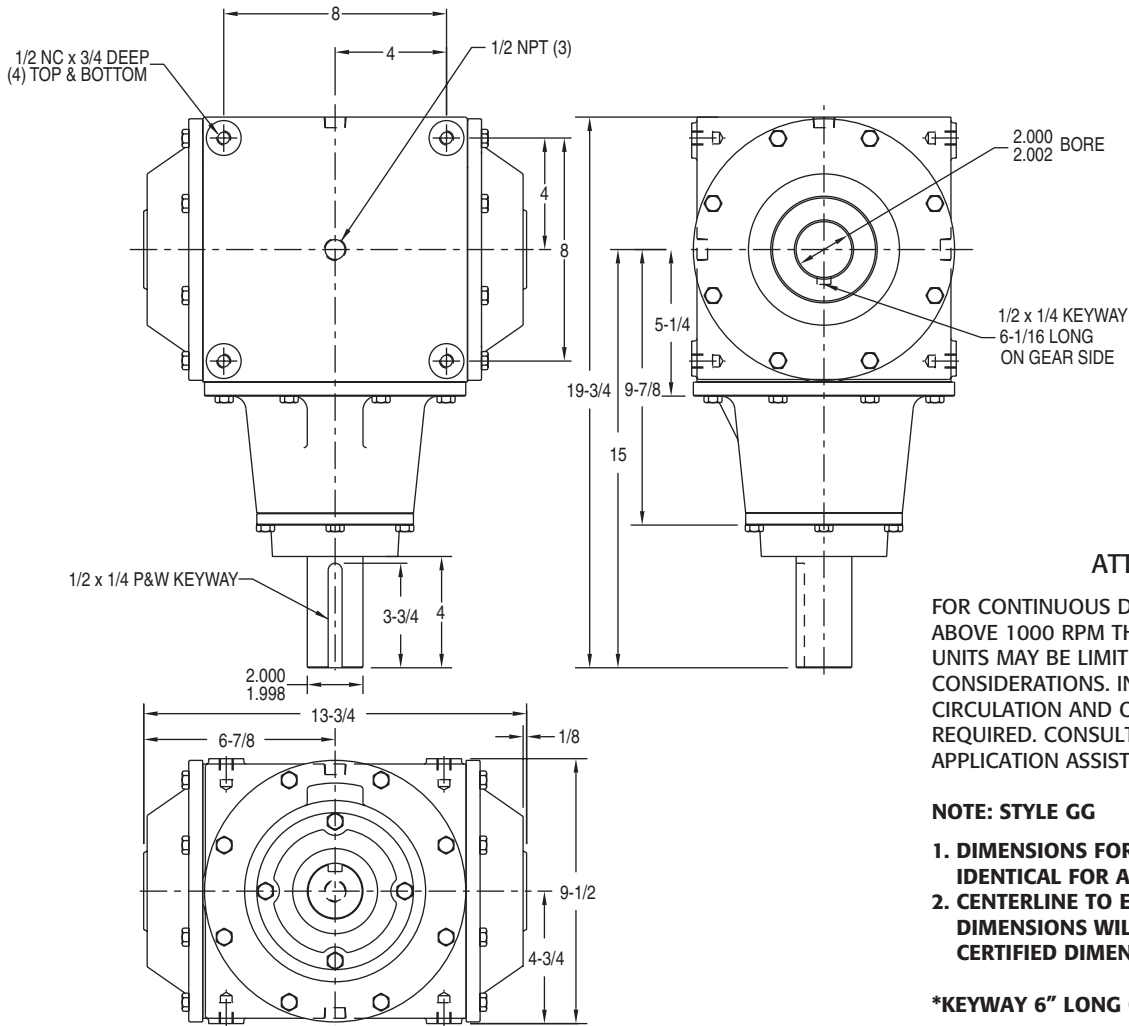

**ATTENTION**

FOR CONTINUOUS DUTY APPLICATIONS ABOVE 1000 RPM THE CAPACITY OF THESE UNITS MAY BE LIMITED BY THERMAL CONSIDERATIONS. IN THESE CASES OIL CIRCULATION AND OIL COOLING MAY BE REQUIRED. CONSULT THE FACTORY FOR APPLICATION ASSISTANCE.

**NOTE: STYLE GG**

1. DIMENSIONS FOR SHAFTS A, AND A1 ARE IDENTICAL FOR ALL RATIOS.
2. CENTERLINE TO END OF SHAFT DIMENSIONS WILL VARY. REQUEST CERTIFIED DIMENSIONAL PRINTS.

**\*KEYWAY 6" LONG ON GEAR SIDE**

**DRY SHIPPING WEIGHTS**

STYLES A, B..... 175 lbs.  
STYLES GG..... 225 lbs.

**FOR LUBRICATION AND INSTALLATION INSTRUCTIONS - REFER TO SECTION R**

**STANDARD STYLES AVAILABLE**

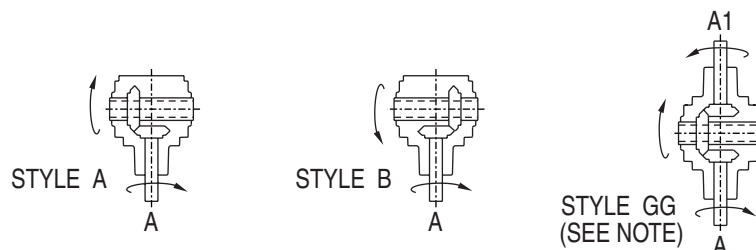

CONSULT FACTORY FOR VERTICAL SHAFT LUBRICATION RECOMMENDATIONS  
INPUT SHAFT CAN BE ROTATED IN EITHER DIRECTION

DIMENSIONS SHOWN ARE FOR REFERENCE ONLY.  
CERTIFIED PRINTS ARE AVAILABLE UPON REQUEST.



## MODEL 1200

### FEATURES

- Rugged ductile iron housing provides maximum gear and bearing support.
- High alloy shafting for greater strength.
- Tapered roller bearings for endurance and strength.
- Spiral bevel gearing to assure low noise level at higher operating speeds.
- Choice of six (6) standard gear ratios.
- Available with 8" or 10" pitch diameter gears in 1:1 ratio to provide optimum design flexibility.
- Heavy-duty industrial seals to keep lubricant in and dirt out.
- Universal mounting assures maximum design flexibility.
- Base mounting kits available. (Refer to pages D-65)
- Hub City lubricant recommended. (Refer to section R)
- Hub City "Counter Flow" bearing lubrication system.
- Metric versions available. (Refer to page D-57)

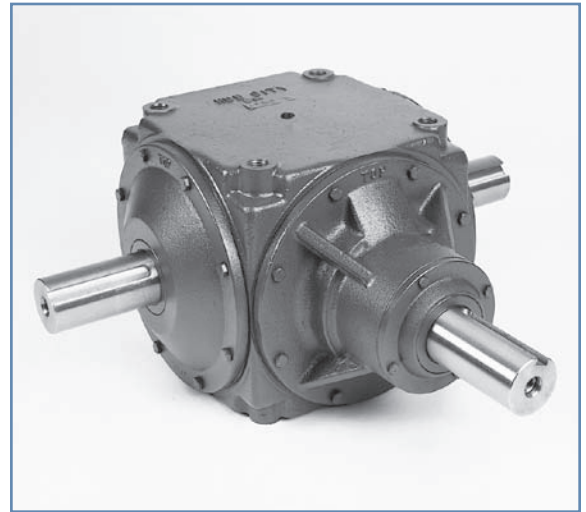

### RATING TABLE

INPUT RPM†		REDUCTION RATIOS					
		SPIRAL 1:1 (8")	SPIRAL 1:1 (10")	SPIRAL 1.33:1Δ	SPIRAL 1.5:1	SPIRAL 2:1	SPIRAL 3:1
1750	INPUT HORSEPOWER	296.00	380.00	246.00	196.00	224.00	118.00
	OUTPUT TORQUE IN. LBS.	10,680.00	13,685.00	11,821.00	10,591.00	16,148.00	12,749.00
	‡INPUT O.H.L.	118.00	177.00	104.00	109.00	102.00	117.00
	‡OUTPUT O.H.L.	396.00	155.00	657.00	1284.00	579.00	2217.00
1150	INPUT HORSEPOWER	203.50	261.00	168.00	134.00	155.00	79.00
	OUTPUT TORQUE IN. LBS.	11,148.00	14,304.00	12,278.00	11,005.00	16,931.00	13,051.00
	‡INPUT O.H.L.	238.00	391.00	209.00	213.00	196.00	236.00
	‡OUTPUT O.H.L.	816.00	570.00	1009.00	1692.00	960.00	2805.00
850	INPUT HORSEPOWER	154.70	199.00	128.00	102.00	116.00	60.00
	OUTPUT TORQUE IN. LBS.	11,466.00	14,755.00	12,694.00	11,347.00	17,180.00	13,363.00
	‡INPUT O.H.L.	296.00	570.00	319.00	326.00	250.00	292.00
	‡OUTPUT O.H.L.	1185.00	918.00	1244.00	1980.00	1199.00	3216.00
690	INPUT HORSEPOWER	127.80	164.50	106.00	85.00	97.00	49.00
	OUTPUT TORQUE IN. LBS.	11,670.00	15,025.00	12,900.00	11,551.00	17,584.00	13,521.00
	‡INPUT O.H.L.	437.00	714.00	396.00	391.00	340.00	392.00
	‡OUTPUT O.H.L.	1473.00	1197.00	1297.00	2081.00	1290.00	3591.00
400	INPUT HORSEPOWER	77.20	99.70	63.00	50.00	57.00	30.00
	OUTPUT TORQUE IN. LBS.	12,160.00	15,709.00	13,270.00	11,893.00	18,000.00	14,197.00
	‡INPUT O.H.L.	872.00	1153.00	759.00	777.00	532.00	713.00
	‡OUTPUT O.H.L.	2354.00	2050.00	2137.00	3001.00	1905.00	4200.00
300	INPUT HORSEPOWER	59.00	76.30	48.00	39.00	44.00	22.50
	OUTPUT TORQUE IN. LBS.	12,390.00	16,029.00	13,453.00	12,057.00	18,479.00	14,267.00
	‡INPUT O.H.L.	1148.00	1431.00	911.00	932.00	692.00	910.00
	‡OUTPUT O.H.L.	2911.00	2594.00	2594.00	3475.00	2668.00	4200.00
100	INPUT HORSEPOWER	21.00	27.00	17.00	14.00	16.00	7.70
	OUTPUT TORQUE IN. LBS.	13,230.00	17,017.00	14,184.00	13,087.00	20,281.00	14,600.00
	‡INPUT O.H.L.	2495.00	2813.00	1012.00	1079.00	820.00	1236.00
	‡OUTPUT O.H.L.	4200.00	4200.00	4200.00	4200.00	4200.00	4200.00
WR <sup>2</sup> (Lb. In. <sup>2</sup> ) REFERRED TO HIGH SPEED SHAFT	STYLE						
	A, B	422.5	691.7	181.6	176.9	152.2	95.9
	C, D, E, F	416.2	685.5	178.0	174.2	150.6	95.2
	G	614.1	1018.2	264.4	270.6	229.9	135.4
	GG	627.1	1031.1	266.4	249.0	220.4	149.5
WR <sup>2</sup> (Lb. In. <sup>2</sup> ) REFERRED TO LOW SPEED SHAFT	A, B	422.5	691.7	321.2	398.1	608.6	862.8
	C, D, E, F	416.2	685.5	315.0	391.9	602.4	856.6
	G	614.1	1018.2	467.6	608.8	919.6	1218.2
	GG	627.1	1031.1	471.2	560.4	881.4	1345.2

†FOR HIGHER INPUT SPEEDS CONSULT FACTORY.

‡OVERHUNG LOAD IN LBS. AT CENTER OF SHAFT EXTENSIONS.

ΔMFG. TO ORDER - CONSULT FACTORY FOR PRICE AND DELIVERY



# MODEL 1200

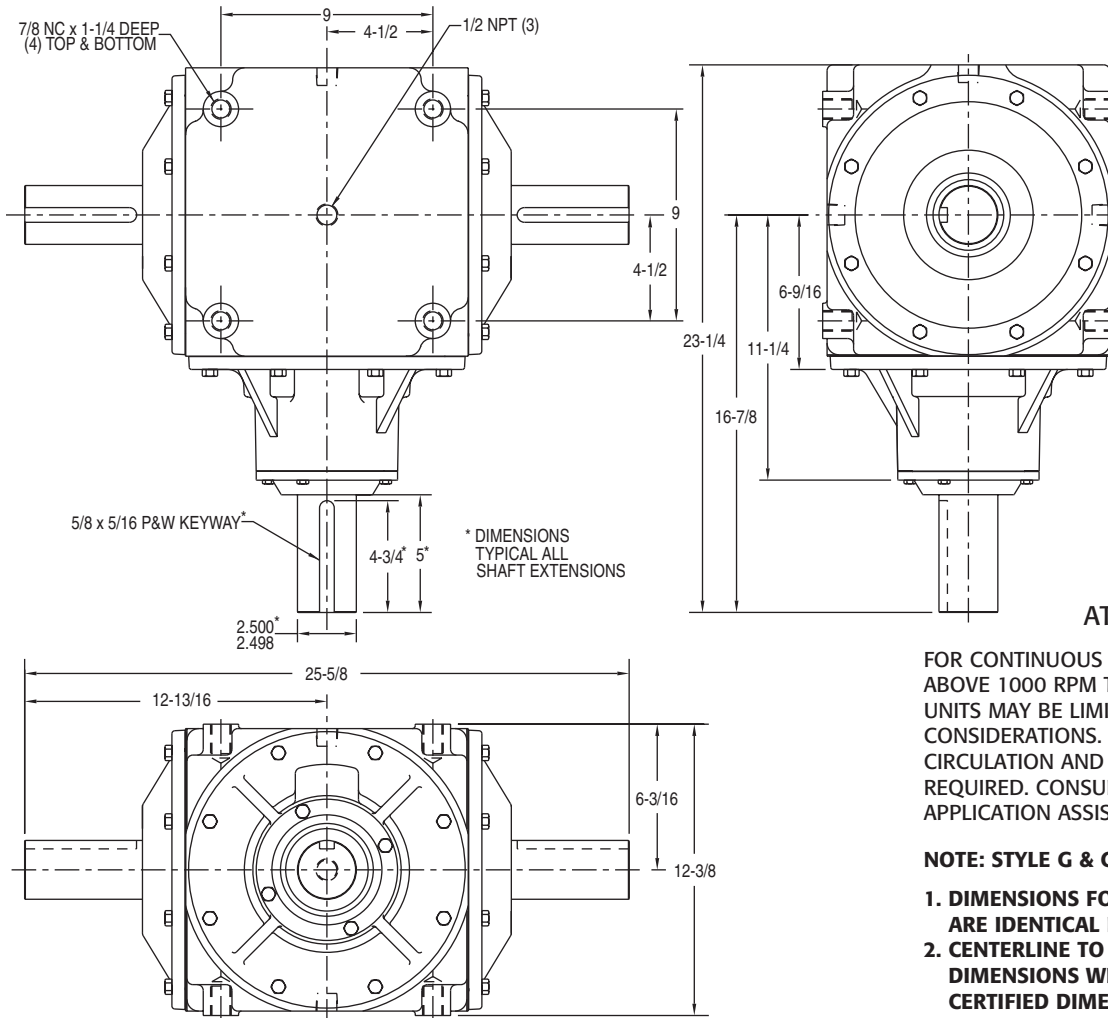

### ATTENTION

FOR CONTINUOUS DUTY APPLICATIONS ABOVE 1000 RPM THE CAPACITY OF THESE UNITS MAY BE LIMITED BY THERMAL CONSIDERATIONS. IN THESE CASES OIL CIRCULATION AND OIL COOLING MAY BE REQUIRED. CONSULT THE FACTORY FOR APPLICATION ASSISTANCE.

### NOTE: STYLE G & GG

1. DIMENSIONS FOR SHAFTS A, A1, AND A2 ARE IDENTICAL FOR ALL RATIOS.
2. CENTERLINE TO END OF SHAFT DIMENSIONS WILL VARY. REQUEST CERTIFIED DIMENSIONAL PRINTS.

### DRY SHIPPING WEIGHTS

STYLES A, B, C, D, E, F ..... 300 lbs.  
 STYLES G ..... 315 lbs.  
 STYLES GG ..... 330 lbs.

FOR LUBRICATION AND INSTALLATION INSTRUCTIONS - REFER TO SECTION R

### STANDARD STYLES AVAILABLE

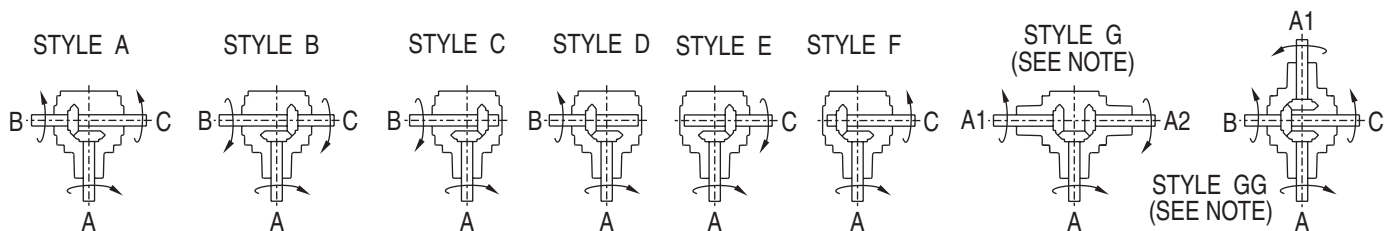

DIMENSIONS SHOWN ARE FOR REFERENCE ONLY. CERTIFIED PRINTS ARE AVAILABLE UPON REQUEST.

CONSULT FACTORY FOR VERTICAL SHAFT LUBRICATION RECOMMENDATIONS  
 INPUT SHAFT CAN BE ROTATED IN EITHER DIRECTION

D  
RATING AND DIMENSIONS





## MODEL 1250

### FEATURES

- Shaft mounted design for direct mounting on drive shaft of equipment to be driven.
- Rugged ductile iron housing provides maximum gear and bearing support.
- High alloy shafting for greater strength.
- Tapered roller bearings for endurance and strength.
- Spiral bevel gearing to assure low noise level at higher operating speeds.
- Choice of four (4) standard gear ratios.
- Heavy-duty industrial seals to keep lubricant in and dirt out.
- Hub City lubricant recommended. (Refer to section R)
- Hub City "Counter Flow" bearing lubrication system.
- Metric versions available. (Refer to page D-58)

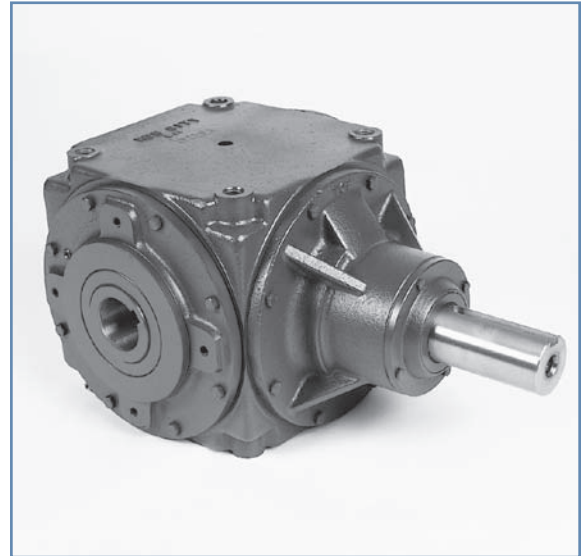

### RATING TABLE

INPUT RPM†		REDUCTION RATIOS			
		SPIRAL 1:1	SPIRAL 1.5:1	SPIRAL 2:1	SPIRAL 3:1
1750	INPUT HORSEPOWER	380.00	196.00	224.00	118.00
	OUTPUT TORQUE IN. LBS.	13,685.00	10,594.00	16,148.00	12,749.00
	‡INPUT O.H.L.	177.00	109.00	102.00	117.00
1150	INPUT HORSEPOWER	261.00	134.00	155.00	79.00
	OUTPUT TORQUE IN. LBS.	14,304.00	11,005.00	16,931.00	13,051.00
	‡INPUT O.H.L.	391.00	213.00	196.00	236.00
850	INPUT HORSEPOWER	199.00	102.00	116.00	60.00
	OUTPUT TORQUE IN. LBS.	14,755.00	11,347.00	17,180.00	13,363.00
	‡INPUT O.H.L.	570.00	326.00	250.00	292.00
690	INPUT HORSEPOWER	164.50	85.00	97.00	49.00
	OUTPUT TORQUE IN. LBS.	15,025.00	11,551.00	17,584.00	13,521.00
	‡INPUT O.H.L.	714.00	391.00	340.00	392.00
400	INPUT HORSEPOWER	99.70	50.00	57.00	30.00
	OUTPUT TORQUE IN. LBS.	15,709.00	11,843.00	18,000.00	14,197.00
	‡INPUT O.H.L.	1153.00	777.00	532.00	713.00
300	INPUT HORSEPOWER	76.30	39.00	44.00	22.50
	OUTPUT TORQUE IN. LBS.	16,029.00	12,057.00	18,479.00	14,267.00
	‡INPUT O.H.L.	1431.00	932.00	692.00	910.00
100	INPUT HORSEPOWER	27.00	14.00	16.00	7.70
	OUTPUT TORQUE IN. LBS.	17,017.00	13,087.00	20,281.00	14,600.00
	‡INPUT O.H.L.	2813.00	1079.00	820.00	1236.00
WR <sup>2</sup> (Lb. In. <sup>2</sup> ) REFERRED TO HIGH SPEED SHAFT	STYLE				
	A, B GG	739.20 1078.50	194.00 266.00	161.30 229.60	100.20 153.70
WR <sup>2</sup> (Lb. In. <sup>2</sup> ) REFERRED TO LOW SPEED SHAFT	A, B GG	739.20 1078.50	436.40 598.60	645.40 918.20	901.70 1384.10

†FOR HIGHER INPUT SPEEDS CONSULT FACTORY.

‡OVERHUNG LOAD IN LBS. AT CENTER OF SHAFT EXTENSIONS.



# MODEL 1250

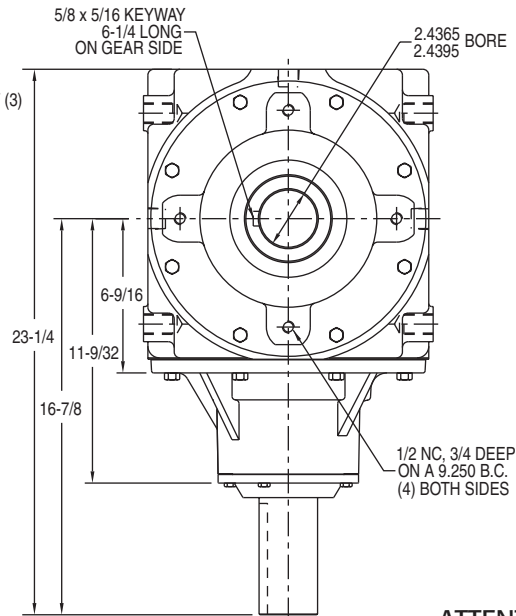
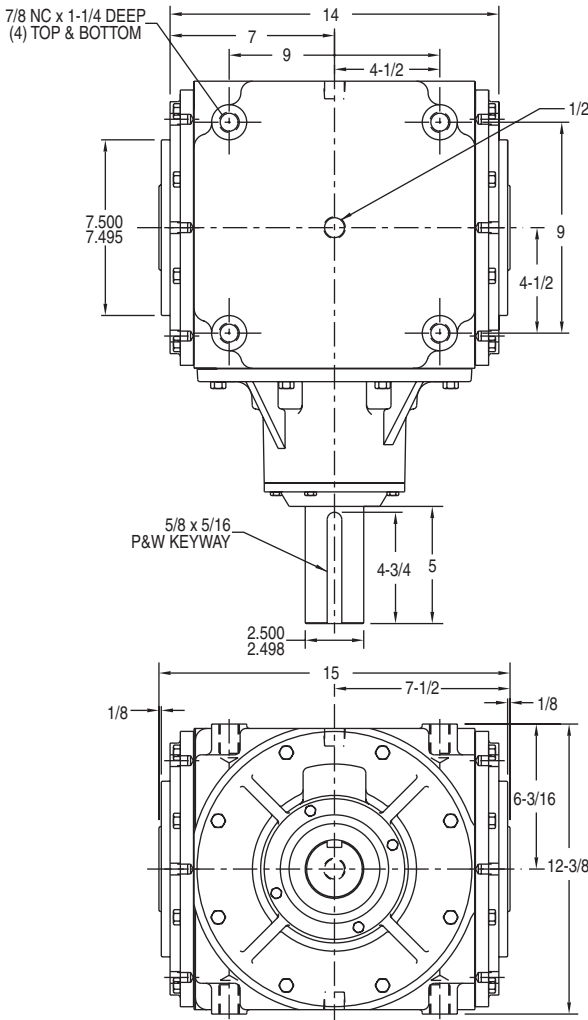

### ATTENTION

FOR CONTINUOUS DUTY APPLICATIONS ABOVE 1000 RPM THE CAPACITY OF THESE UNITS MAY BE LIMITED BY THERMAL CONSIDERATIONS. IN THESE CASES OIL CIRCULATION AND OIL COOLING MAY BE REQUIRED. CONSULT THE FACTORY FOR APPLICATION ASSISTANCE.

### NOTE: STYLE GG

1. DIMENSIONS FOR SHAFTS A, AND A1 ARE IDENTICAL FOR ALL RATIOS.
2. CENTERLINE TO END OF SHAFT DIMENSIONS WILL VARY. REQUEST CERTIFIED DIMENSIONAL PRINTS.

\*KEYWAY 6-1/4" LONG ON GEAR SIDE.

### DRY SHIPPING WEIGHTS

STYLES A, B ..... 305 lbs.  
 STYLES GG ..... 330 lbs.

### FOR LUBRICATION AND INSTALLATION INSTRUCTIONS - REFER TO SECTION R

DIMENSIONS SHOWN ARE FOR REFERENCE ONLY. CERTIFIED PRINTS ARE AVAILABLE UPON REQUEST.

### STANDARD STYLES AVAILABLE

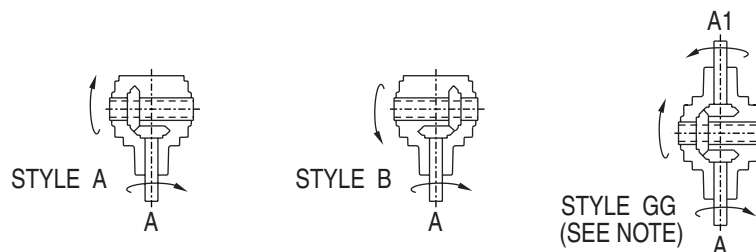

CONSULT FACTORY FOR VERTICAL SHAFT LUBRICATION RECOMMENDATIONS  
 INPUT SHAFT CAN BE ROTATED IN EITHER DIRECTION



## MODEL 1700

### FEATURES

- Rigid steel weldment housing designed for positive gear and bearing support.
- High tensile shafts for extra strength.
- Tapered roller bearings for endurance and strength.
- Spiral bevel gearing to assure low noise level at higher operating speeds.
- Choice of five (5) standard gear ratios.
- Heavy-duty industrial seals to keep lubricant in and dirt out.
- Designed for high temperature applications.
- Special lubrication devices and equipment available based upon application.
- Made to order – see application requirements on page D-47.

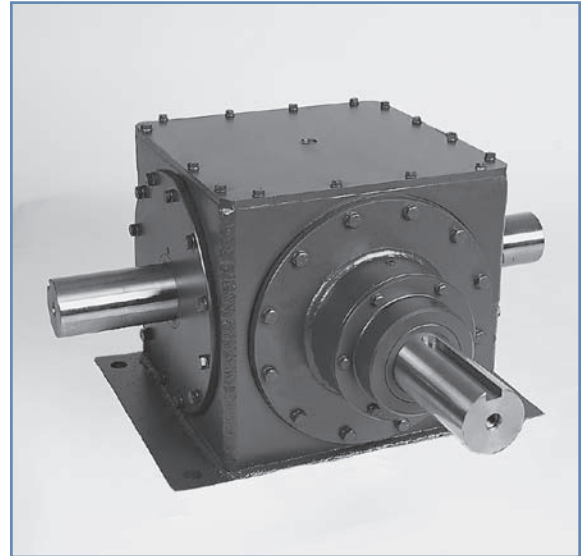

### RATING TABLE

INPUT RPM†		REDUCTION RATIOS				
		SPIRAL 1:1	SPIRAL 1.33:1	SPIRAL 1.5:1	SPIRAL 2:1	SPIRAL 3:1
1750	INPUT HORSEPOWER	701	334	301	305	159
	OUTPUT TORQUE IN. LBS.	25,246	15,998	16,260	21,969	17,179
1150	INPUT HORSEPOWER	482	228	206	210	108
	OUTPUT TORQUE IN. LBS.	26,416	16,619	16,934	23,018	17,757
850	INPUT HORSEPOWER	369	174	157	159	81
	OUTPUT TORQUE IN. LBS.	27,360	17,159	17,462	23,579	18,018
690	INPUT HORSEPOWER	305	144	130	132	67
	OUTPUT TORQUE IN. LBS.	27,859	17,493	17,811	24,114	18,360
400	INPUT HORSEPOWER	186	87	78	79	40
	OUTPUT TORQUE IN. LBS.	29,307	18,232	18,435	24,895	18,907
300	INPUT HORSEPOWER	142	66	59	60	30
	OUTPUT TORQUE IN. LBS.	29,831	18,441	18,592	25,210	18,907
100	INPUT HORSEPOWER	50	23	21	21	11
	OUTPUT TORQUE IN. LBS.	31,513	19,279	19,853	26,470	20,798
WR <sup>2</sup> (Lb. In. <sup>2</sup> ) REFERRED TO HIGH SPEED SHAFT	STYLE					
	A, B	1975	667	540	462	324
	C, D, E, F	1900	626	509	445	317
	G	2935	939	740	649	419
	GG	2955	937	812	692	534
WR <sup>2</sup> (Lb. In. <sup>2</sup> ) REFERRED TO LOW SPEED SHAFT	A, B	1975	1179	1215	1847	2914
	C, D, E, F	1900	1110	1145	1781	2850
	G	2935	1668	1666	2594	3774
	GG	2955	1665	1828	2767	4806

†FOR HIGHER INPUT SPEEDS CONSULT FACTORY.

‡OVERHUNG LOAD IN LBS. AT CENTER OF SHAFT EXTENSIONS.



# MODEL 1700

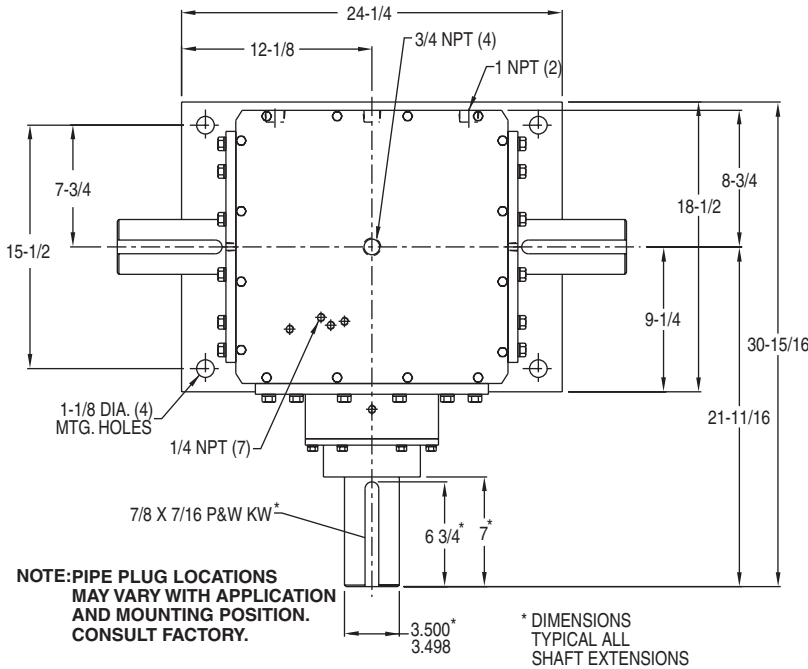

NOTE: PIPE PLUG LOCATIONS MAY VARY WITH APPLICATION AND MOUNTING POSITION. CONSULT FACTORY.

\* DIMENSIONS TYPICAL ALL SHAFT EXTENSIONS

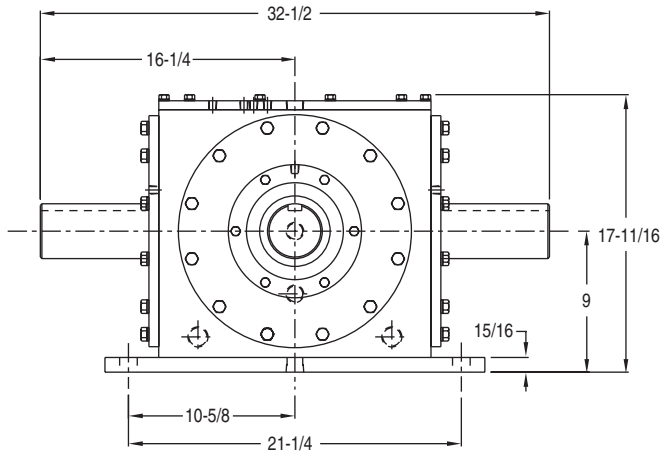

### APPLICATION DATA REQUIRED BEFORE ORDER ENTRY

1. What is drive expected to accomplish?
2. What is the size and type of the power source?
3. What is the HP/Torque requirement and type of the load?
4. What is the input RPM?
5. What is the gear ratio?
6. How are the power source and load connected? If other than coupling connection, what are the details? Such as the size and pitch of sprocket or pulley and the direction of the OHL?
7. Are there special environmental considerations? Temperature extremes (hot or cold), dust, enclosures, etc.?
8. Are there special lubrication problems? Such as vertical shafts or angled mounting?
9. Which style is required? (A, B, C, etc.)
10. Are any modifications required in shaft size, shaft length or mounting configuration?

### NOTE: STYLE G & GG

1. DIMENSIONS FOR SHAFTS A, A1, AND A2 ARE IDENTICAL FOR ALL RATIOS.
2. CENTERLINE TO END OF SHAFT DIMENSIONS WILL VARY. REQUEST CERTIFIED DIMENSIONAL PRINTS.

FOR LUBRICATION AND INSTALLATION INSTRUCTIONS - REFER TO SECTION R

DRY SHIPPING WEIGHT 850 LBS.

### STANDARD STYLES AVAILABLE

DIMENSIONS SHOWN ARE FOR REFERENCE ONLY. CERTIFIED PRINTS ARE AVAILABLE UPON REQUEST.

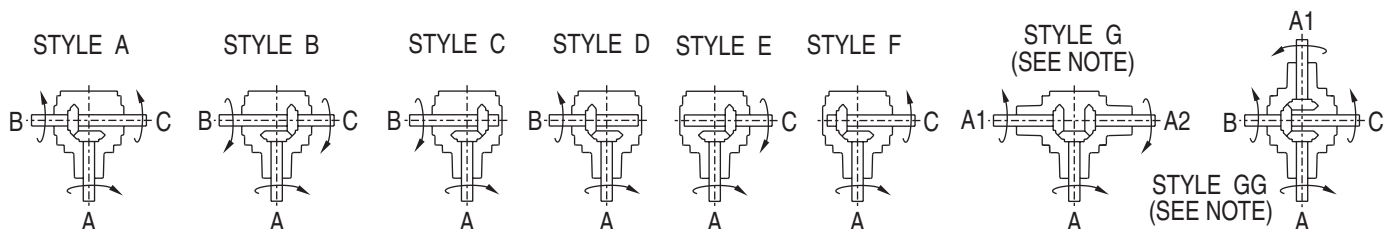

CONSULT FACTORY FOR VERTICAL SHAFT LUBRICATION RECOMMENDATIONS  
INPUT SHAFT CAN BE ROTATED IN EITHER DIRECTION



## MODEL 2200

### FEATURES

- Rigid steel weldment housing designed for positive gear and bearing support.
- High tensile shafts for extra strength.
- Tapered roller bearings for endurance and strength.
- Spiral bevel gearing to assure low noise level at higher operating speeds.
- Choice of four (4) standard gear ratios.
- Heavy-duty industrial seals to keep lubricant in and dirt out.
- Designed for high temperature applications.
- Special lubrication devices and equipment available based upon application.
- Made to order – see application requirements on page D-49.

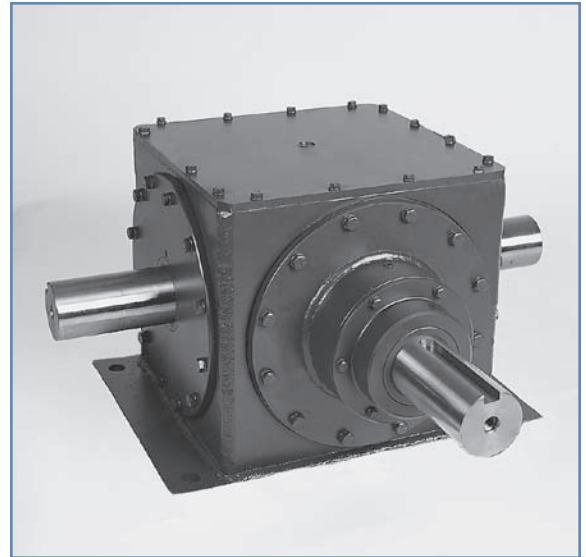

### RATING TABLE

INPUT RPM†		REDUCTION RATIOS			
		SPIRAL 1:1	SPIRAL 1.33:1	SPIRAL 1.5:1	SPIRAL 3:1
1750	INPUT HORSEPOWER	1,250	491	480	237
	OUTPUT TORQUE IN. LBS.	45,018	23,518	25,930	25,600
1150	INPUT HORSEPOWER	868	337	330	162
	OUTPUT TORQUE IN. LBS.	47,570	24,564	27,128	26,635
850	INPUT HORSEPOWER	659	257	251	122
	OUTPUT TORQUE IN. LBS.	48,863	25,334	27,916	27,138
690	INPUT HORSEPOWER	549	212	208	101
	OUTPUT TORQUE IN. LBS.	50,146	25,754	28,498	27,676
400	INPUT HORSEPOWER	335	128	126	60
	OUTPUT TORQUE IN. LBS.	52,783	26,683	29,779	28,361
300	INPUT HORSEPOWER	257	98	96	46
	OUTPUT TORQUE IN. LBS.	53,991	27,362	30,252	28,992
100	INPUT HORSEPOWER	92	35	34	16
	OUTPUT TORQUE IN. LBS.	57,983	29,338	32,142	30,252
WR <sup>2</sup> (Lb. In. <sup>2</sup> ) REFERRED TO HIGH SPEED SHAFT	STYLE				
	A, B	5605	1480	1384	729
	C, D, E, F	5400	1420	1339	718
	G	8028	1885	2101	918
WR <sup>2</sup> (Lb. In. <sup>2</sup> ) REFERRED TO LOW SPEED SHAFT	GG	8282	2205	2051	1200
	A, B	5605	2619	3115	6563
	C, D, E, F	5400	2526	3014	6465
	G	8028	3350	4727	8258
LOW SPEED SHAFT	GG	8282	3918	4615	10795

†FOR HIGHER INPUT SPEEDS CONSULT FACTORY.

‡OVERHUNG LOAD IN LBS. AT CENTER OF SHAFT EXTENSIONS.



# MODEL 2200

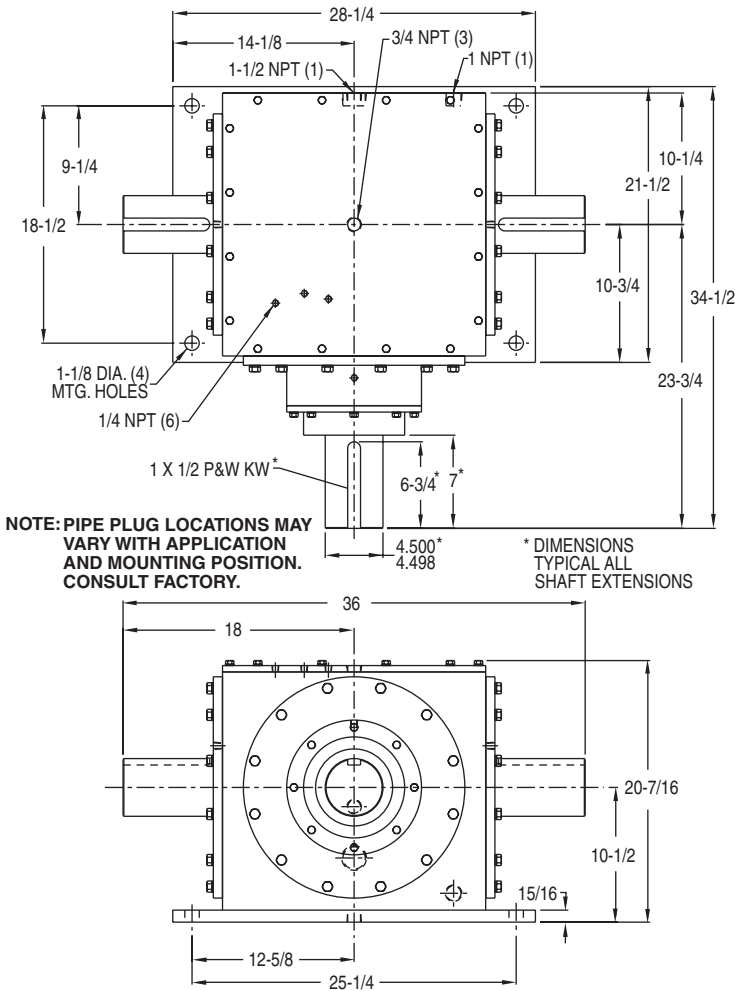

## APPLICATION DATA REQUIRED BEFORE ORDER ENTRY

1. What is drive expected to accomplish?
2. What is the size and type of the power source?
3. What is the HP/Torque requirement and type of the load?
4. What is the input RPM?
5. What is the gear ratio?
6. How are the power source and load connected? If other than coupling connection, what are the details? Such as the size and pitch of sprocket or pulley and the direction of the OHL?
7. Are there special environmental considerations? Temperature extremes (hot or cold), dust, enclosures, etc.?
8. Are there special lubrication problems? Such as vertical shafts or angled mounting?
9. Which style is required? (A, B, C, etc.)
10. Are any modifications required in shaft size, shaft length or mounting configuration?

### NOTE: STYLE G & GG

1. DIMENSIONS FOR SHAFTS A, A1, AND A2 ARE IDENTICAL FOR ALL RATIOS.
2. CENTERLINE TO END OF SHAFT DIMENSIONS WILL VARY. REQUEST CERTIFIED DIMENSIONAL PRINTS.

FOR LUBRICATION AND INSTALLATION INSTRUCTIONS - REFER TO SECTION R

DRY SHIPPING WEIGHT 1,350 LBS.

## STANDARD STYLES AVAILABLE

DIMENSIONS SHOWN ARE FOR REFERENCE ONLY. CERTIFIED PRINTS ARE AVAILABLE UPON REQUEST.

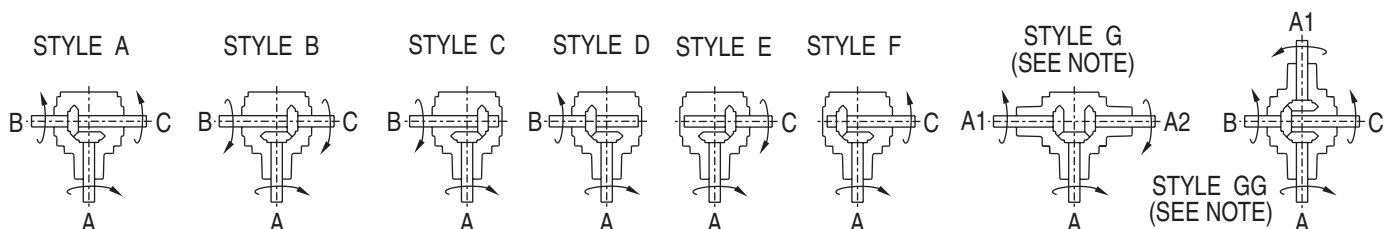

CONSULT FACTORY FOR VERTICAL SHAFT LUBRICATION RECOMMENDATIONS  
INPUT SHAFT CAN BE ROTATED IN EITHER DIRECTION





## MODEL 790

### FEATURES

- Shaft mounted design for direct mounting on drive shaft of equipment to be driven.
- Rugged cast iron housing designed for rigid gear and bearing support.
- Tapered roller bearings for endurance and strength.
- Hub City “Counter Flow” bearing lubrication system.
- Heavy-duty industrial seals to keep lubricant in and dirt out.
- Choice of two (2) gear ratios.
- Choice of three (3) stock output bore sizes.
- Hub City lubricant recommended. (Refer to section R)



### RATING TABLE

INPUT RPM (PINION SHAFT)†		STRAIGHT BEVEL GEAR		SPIRAL BEVEL GEAR	
		2:1 RATIO		Δ3.78:1 RATIO	
		OUTPUT RPM	RATINGS	OUTPUT RPM	RATINGS
3000	INPUT HORSEPOWER OUTPUT TORQUE IN. LBS. ‡INPUT O.H.L.			800.0	64.00 4941.00 320.00
2400	INPUT HORSEPOWER OUTPUT TORQUE IN. LBS. ‡INPUT O.H.L.			640.0	52.00 5018.00 376.00
1750	INPUT HORSEPOWER OUTPUT TORQUE IN. LBS. ‡INPUT O.H.L.			467.0	39.00 5158.00 464.00
1150	INPUT HORSEPOWER OUTPUT TORQUE IN. LBS. ‡INPUT O.H.L.	575.0	24.60 2696.00 589.00	307.0	26.00 5231.00 589.00
850	INPUT HORSEPOWER OUTPUT TORQUE IN. LBS. ‡INPUT O.H.L.	425.0	18.53 2748.00 699.00	227.0	19.00 5170.00 699.00
690	INPUT HORSEPOWER OUTPUT TORQUE IN. LBS. ‡INPUT O.H.L.	345.0	15.80 2886.00 780.00	184.0	15.90 5337.00 780.00
400	INPUT HORSEPOWER OUTPUT TORQUE IN. LBS. ‡INPUT O.H.L.	200.0	9.69 3054.00 900.00	107.0	9.40 5426.00 900.00
300	INPUT HORSEPOWER OUTPUT TORQUE IN. LBS. ‡INPUT O.H.L.	150.0	7.94 3336.00 900.00	80.0	7.20 5558.00 900.00
200	INPUT HORSEPOWER OUTPUT TORQUE IN. LBS. ‡INPUT O.H.L.	100.0	5.35 3371.00 900.00	53.3	4.80 5562.00 900.00
100	INPUT HORSEPOWER OUTPUT TORQUE IN. LBS. ‡INPUT O.H.L.	50.0	2.85 3592.00 900.00	26.7	2.50 5783.00 900.00

†FOR HIGHER INPUT SPEEDS CONSULT FACTORY.

‡OVERHUNG LOAD IN LBS. AT CENTER OF SHAFT EXTENSIONS.

ΔCW INPUT ROTATION PREFERRED. CCW CONSULT FACTORY





**MODEL 790**

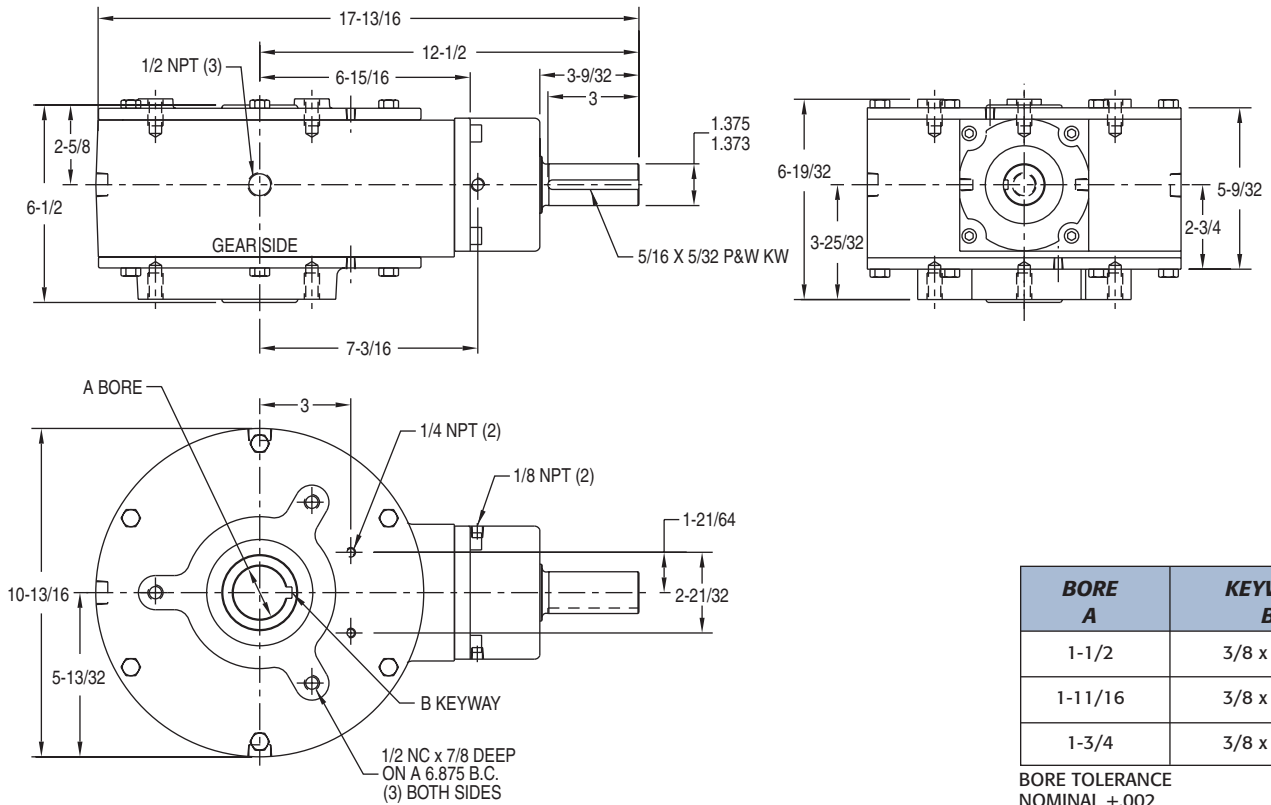

**D**  
**RATING AND DIMENSIONS**

DRY SHIPPING WEIGHT 90 LBS.

**FOR LUBRICATION AND INSTALLATION INSTRUCTIONS - REFER TO SECTION R**

DIMENSIONS SHOWN ARE FOR REFERENCE ONLY.  
CERTIFIED PRINTS ARE AVAILABLE UPON REQUEST.



## MODEL 920

### FEATURES

- Shaft mounted design for direct mounting on drive shaft of equipment to be driven.
- Rugged cast iron housing designed for rigid gear and bearing support.
- Tapered roller bearings for endurance and strength.
- Spiral bevel gearing to assure low noise level at higher operating speeds.
- Choice of six (6) gear ratios.
- Heavy-duty industrial seals to keep lubricant in and dirt out.
- Differential type spiral bevel gearing to provide maximum RPM reduction and low noise levels at higher operating speeds.
- Choice of four (4) stock output bore sizes.
- Hub City lubricant recommended. (Refer to section R)



### RATING TABLE

INPUT RPM (PINION SHAFT)†		SPIRAL BEVEL GEARS											
		Δ3.25:1		Δ3.78:1		Δ4.11:1		Δ4.86:1		Δ5.57:1		Δ6.67:1	
		OUTPUT RPM	RATINGS	OUTPUT RPM	RATINGS	OUTPUT RPM	RATINGS	OUTPUT RPM	RATINGS	OUTPUT RPM	RATINGS	OUTPUT RPM	RATINGS
3000	INPUT HORSEPOWER	923.00	131.33	793.60	118.11	730.00	110.00	618.00	76.00	538.60	65.08	450.00	48.00
	OUTPUT TORQUE IN. LBS.		8964.00		9376.00		9480.00		7752.00		7612.00		6720.00
	‡INPUT O.H.L.		80.00		75.00		65.00		85.00		100.00		110.00
2400	INPUT HORSEPOWER	738.50	107.34	634.90	96.59	584.00	90.00	494.00	62.00	430.90	52.84	360.00	38.50
	OUTPUT TORQUE IN. LBS.		9156.00		9584.00		9720.00		7920.00		7725.00		6732.00
	‡INPUT O.H.L.		283.00		293.00		286.00		299.00		314.00		319.00
1750	INPUT HORSEPOWER	538.50	80.51	463.00	71.50	426.00	66.00	360.00	46.00	314.20	39.18	263.00	28.50
	OUTPUT TORQUE IN. LBS.		9420.00		9731.00		9780.00		8040.00		7855.00		6828.00
	‡INPUT O.H.L.		450.00		450.00		450.00		450.00		450.00		450.00
1150	INPUT HORSEPOWER	353.80	54.57	304.20	47.60	280.00	44.00	237.00	31.00	206.50	26.32	173.00	19.00
	OUTPUT TORQUE IN. LBS.		9720.00		9860.00		9900.00		8232.00		8030.00		6900.00
	‡INPUT O.H.L.		450.00		450.00		450.00		450.00		450.00		450.00
850	INPUT HORSEPOWER	261.50	41.00	224.90	37.28	207.00	35.00	175.00	24.00	152.60	20.10	127.50	14.00
	OUTPUT TORQUE IN. LBS.		9876.00		10443.00		10644.00		8640.00		8298.00		6948.00
	‡INPUT O.H.L.		450.00		450.00		450.00		450.00		450.00		450.00
690	INPUT HORSEPOWER	212.30	33.74	182.50	30.49	168.00	28.50	142.00	20.00	123.90	16.68	103.50	11.50
	OUTPUT TORQUE IN. LBS.		10008.00		10526.00		10680.00		8880.00		8484.00		6996.00
	‡INPUT O.H.L.		450.00		450.00		450.00		450.00		450.00		450.00
400	INPUT HORSEPOWER	123.00	20.10	105.80	18.18	97.50	17.00	82.20	12.00	71.80	10.05	60.00	7.00
	OUTPUT TORQUE IN. LBS.		10284.00		10824.00		10980.00		9240.00		8818.00		7356.00
	‡INPUT O.H.L.		450.00		450.00		450.00		450.00		450.00		450.00
300	INPUT HORSEPOWER	92.30	15.26	79.40	13.86	73.00	13.00	61.70	9.25	53.90	7.98	45.00	6.00
	OUTPUT TORQUE IN. LBS.		10416.00		10992.00		11208.00		9432.00		9330.00		8400.00
	‡INPUT O.H.L.		450.00		450.00		450.00		450.00		450.00		450.00
200	INPUT HORSEPOWER	61.50	10.33	52.90	9.44	48.50	8.90	41.40	6.30	35.90	5.45	30.00	4.25
	OUTPUT TORQUE IN. LBS.		10572.00		11246.00		11556.00		9648.00		9564.00		8928.00
	‡INPUT O.H.L.		450.00		450.00		450.00		450.00		450.00		450.00
100	INPUT HORSEPOWER	30.75	5.26	26.45	4.85	24.30	4.60	20.70	3.30	17.95	2.86	15.00	2.30
	OUTPUT TORQUE IN. LBS.		10764.00		11554.00		11928.00		10104.00		10034.00		8997.00
	‡INPUT O.H.L.		450.00		450.00		450.00		450.00		450.00		450.00

†FOR HIGHER INPUT SPEEDS CONSULT FACTORY.  
‡OVERHUNG LOAD IN LBS. AT CENTER OF SHAFT EXTENSIONS.

ΔCW INPUT ROTATION PREFERRED. CCW CONSULT FACTORY.  
§MAXIMUM RUNNING TORQUE.



**MODEL 920**

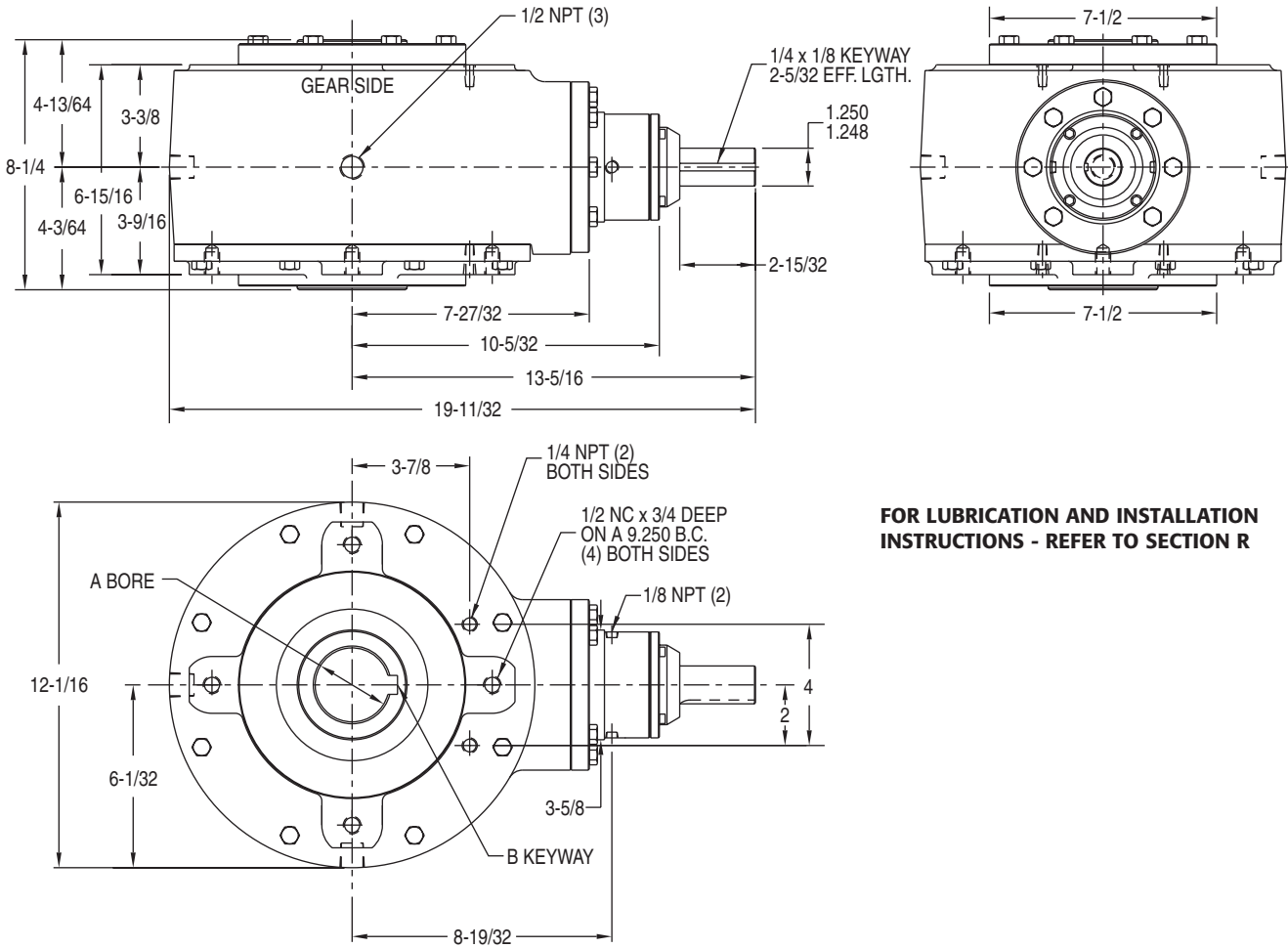

**FOR LUBRICATION AND INSTALLATION INSTRUCTIONS - REFER TO SECTION R**

<b>BORE A</b>	<b>KEYWAY B</b>
1-15/16	1/2 x 1/4
2	1/2 x 1/4
2-1/4	1/2 x 1/4
2-7/16	5/8 x 5/16

BORE TOLERANCE  
NOMINAL +.003

**DRY SHIPPING WEIGHT 143 LBS.**

DIMENSIONS SHOWN ARE FOR REFERENCE ONLY.  
CERTIFIED PRINTS ARE AVAILABLE UPON REQUEST.

**D**  
**RATING AND DIMENSIONS**



## MODEL 950

### FEATURES

- Shaft mounted design for direct mounting on drive shaft of equipment to be driven.
- Rugged cast iron housing designed for rigid gear and bearing support.
- Tapered roller bearings for endurance and strength.
- Spiral bevel gearing to assure low noise level at higher operating speeds.
- Choice of four (4) gear ratios.
- Heavy-duty industrial seals to keep lubricant in and dirt out.
- Differential type spiral bevel gearing to provide maximum RPM reduction and low noise levels at higher operating speeds.
- Choice of three (3) stock output bore sizes.
- Hub City lubricant recommended. (Refer to section R)
- Hub City "Counter Flow" bearing lubrication system.



### RATING TABLE

INPUT RPM†		REDUCTION RATIOS			
		SPIRAL BEVEL GEARS			
		Δ4.56:1	Δ5.50:1	Δ6.50:1	Δ7.33:1
1750	INPUT HORSEPOWER	164.00	152.00	104.00	86.00
	OUTPUT TORQUE IN. LBS.	26,933.00	30,108.00	24,346.00	22,703.00
	‡INPUT O.H.L.	379.00	285.00	426.00	500.00
1150	INPUT HORSEPOWER	112.10	103.00	70.70	57.80
	OUTPUT TORQUE IN. LBS.	28,014.00	31,009.00	25,205.00	23,219.00
	‡INPUT O.H.L.	500.00	500.00	500.00	500.00
850	INPUT HORSEPOWER	84.30	77.80	52.90	43.40
	OUTPUT TORQUE IN. LBS.	28,506.00	31,730.00	25,491.00	23,592.00
	‡INPUT O.H.L.	500.00	500.00	500.00	500.00
690	INPUT HORSEPOWER	69.20	63.90	43.20	35.50
	OUTPUT TORQUE IN. LBS.	28,833.00	32,091.00	25,634.00	23,768.00
	‡INPUT O.H.L.	500.00	500.00	500.00	500.00
400	INPUT HORSEPOWER	40.80	37.80	25.40	21.20
	OUTPUT TORQUE IN. LBS.	29,324.00	32,812.00	25,634.00	24,482.00
	‡INPUT O.H.L.	500.00	500.00	500.00	500.00
300	INPUT HORSEPOWER	31.10	28.70	19.40	16.00
	OUTPUT TORQUE IN. LBS.	29,816.00	33,173.00	26,494.00	24,638.00
	‡INPUT O.H.L.	500.00	500.00	500.00	500.00
200	INPUT HORSEPOWER	21.20	19.40	13.10	10.80
	OUTPUT TORQUE IN. LBS.	30,472.00	33,714.00	26,923.00	24,946.00
	‡INPUT O.H.L.	500.00	500.00	500.00	500.00
100	INPUT HORSEPOWER	10.70	9.80	6.60	5.40
	§OUTPUT TORQUE IN. LBS.	30,799.00	34,074.00	27,210.00	25,225.00
	‡INPUT O.H.L.	500.00	500.00	500.00	500.00

†FOR HIGHER INPUT SPEEDS CONSULT FACTORY.  
‡OVERHUNG LOAD IN LBS. AT CENTER OF SHAFT EXTENSIONS.

ΔCW INPUT ROTATION PREFERRED. CCW CONSULT FACTORY.  
§MAXIMUM RUNNING TORQUE.



**MODEL 950**

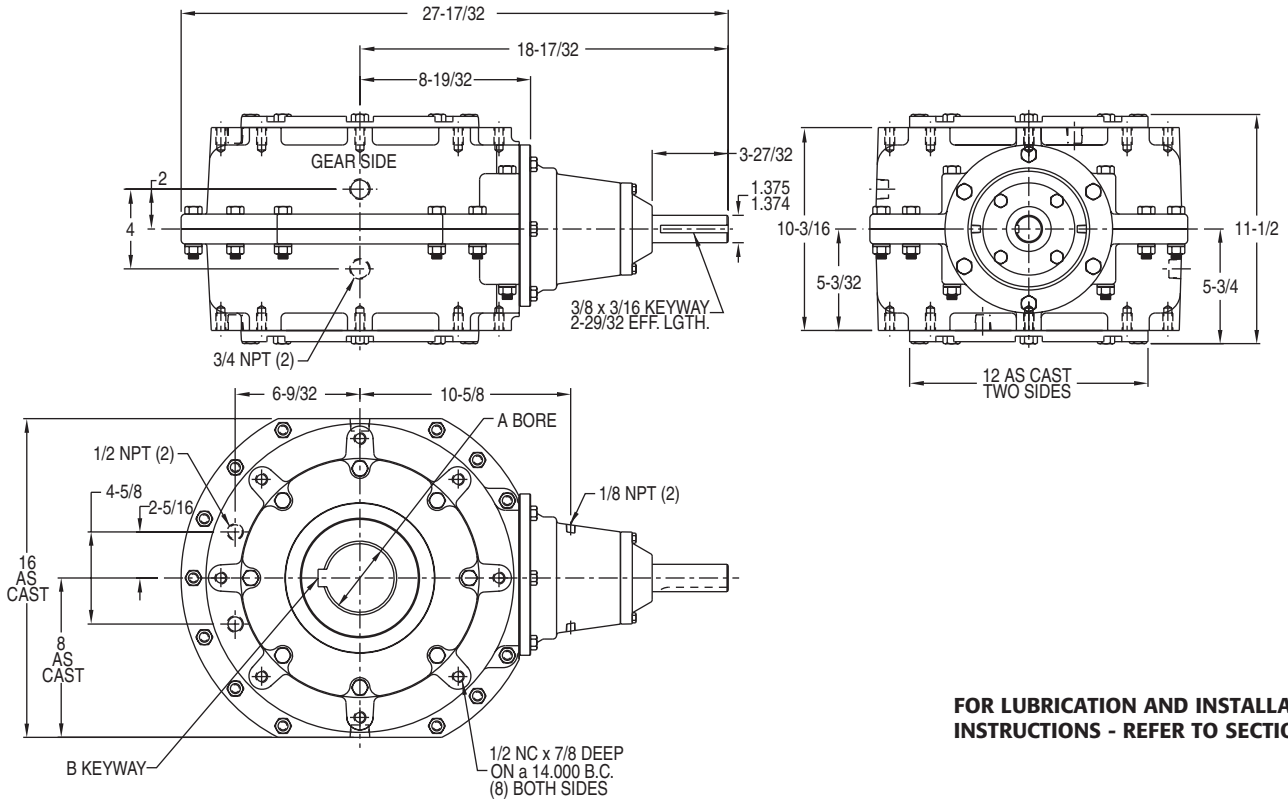

**FOR LUBRICATION AND INSTALLATION INSTRUCTIONS - REFER TO SECTION R**

<b>BORE A</b>	<b>KEYWAY B</b>
3-7/16	7/8 x 7/16
*3-15/16	7/8 x 3/16
*4-7/16	1-1/8 x 9/16

\*OUTPUT SLEEVE NOT NORMALLY STOCKED.  
BORE TOLERANCE NOMINAL +.005

**DRY SHIPPING WEIGHT 340 LBS.**

DIMENSIONS SHOWN ARE FOR REFERENCE ONLY.  
CERTIFIED PRINTS ARE AVAILABLE UPON REQUEST.

**D**  
**RATING AND DIMENSIONS**



## MODELS AD4M, AD5M, AD3M

### FEATURES

- Metric mounting dimensions, bearings and seals.
- Additional features listed on page D-8.
- Available ratios: 1:1SP, 2:1SP.
- Ratings and Assembly styles listed on pages D-8 and D-9.

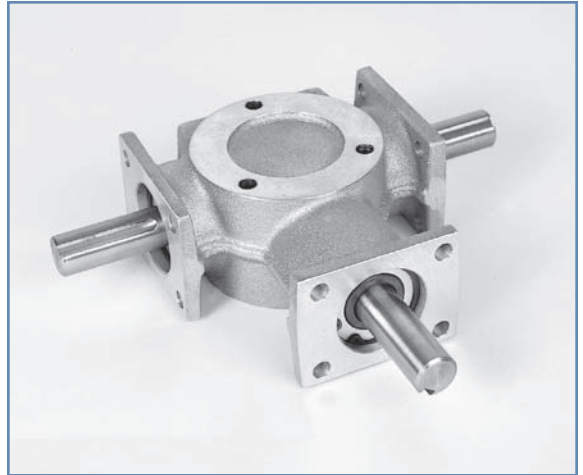

**FOR LUBRICATION AND INSTALLATION INSTRUCTIONS - REFER TO SECTION R**

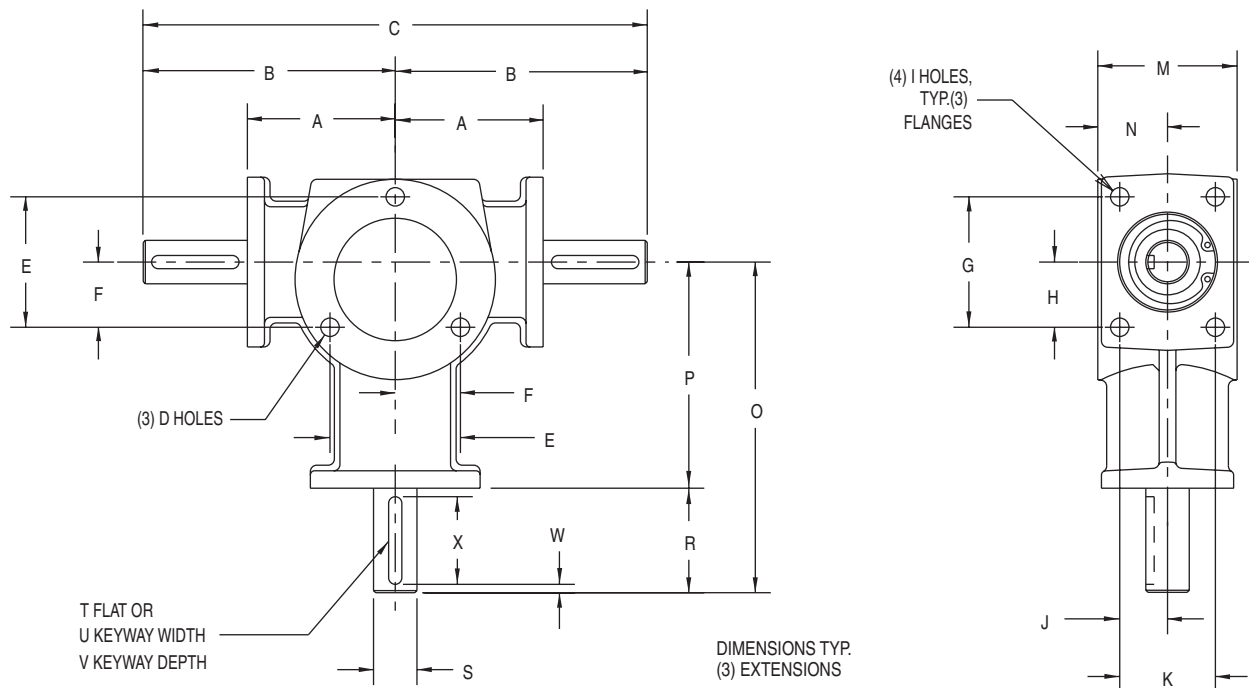

### DIMENSIONS (mm)

MODEL	A	B	C	D	E	F	G	H	I	J	K	M	N	O	P	R	S	T	U	V	W	X
AD4M	35	50	100	5.3	34	17	30	15	4.3	11	22	32	16	70	55	15	9.008 8.981	0.7 Deep	-	-	0	12
AD5M	54	92	184	6.4	48	24	48	24	6.4	18	36	52	26	121	83	38	15.008 14.981	-	5.00 4.96	3	3	30
AD3M	76	127	254	8.4	76	38	76	38	8.4	28	56	76	38	178	127	51	19.008 18.981	-	6.00 5.96	3.5	3	45

NOTE: SP = SPIRAL BEVEL GEARING



## MODELS M3M, 165M, 66M, 800M, 101M, 120M

### FEATURES

- Metric mounting dimensions, hardware, bearings and seals.
- Additional features listed on pages referenced below.
- Available ratios:  
 M3M 1:1, 1.5:1, 2:1  
 165M 1:1, 1:1SP, 1.5:1, 1.5:1SP, 2:1, 2:1SP, 1:1.5SP, 1:2SP  
 66M 1:1, 1:1SP, 1.5:1, 1.53:1SP, 2:1, 2:1SP, 3:1SP, 1:1.53SP, 1:2SP  
 800M 1:1SP, 1.5:1SP, 2:1SP, 3:1SP  
 101M 1:1SP, 1.5:1SP, 2:1SP  
 120M 1:1SP, 1.5:1SP, 2:1SP, 3:1SP
- Ratings and Assembly styles refer to the following pages:  
 M3M Pages D-12, D-13                      800M Pages D-32, D-33  
 165M Pages D-20, D-21                    101M Pages D-38, D-39  
 66M Pages D-24, D-25                    120M Pages D-42, D-43



D

**FOR LUBRICATION AND INSTALLATION INSTRUCTIONS - REFER TO SECTION R**

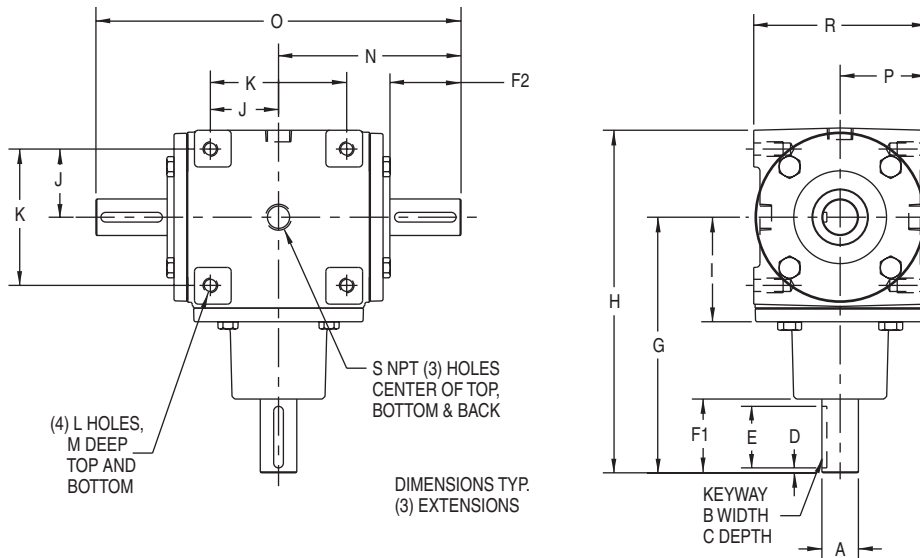

RATING AND DIMENSIONS

### DIMENSIONS (mm)

MODEL	A	B	C	D	E	F1	F2	G	H	I	J	K	L	M	N	O	P	R	S
M3M	15.008 14.981	5.00 4.96	3	2	30	38	35	115	155	45	28	56	M8 x 1.25	10	80	160	40	80	1/8 Inch
165M	25.008* 24.961	8.00 7.95	4	4	45	55	56	185	250	72	54	108	M8 x 1.25	16	135	270	53	106	1/4 Inch
66M	30.008** 29.981	8.00 7.95	4	4	50	61	59	210	281	86	56	112	M12 x 1.75	24	150	300	71	142	1/2 Inch
800M	40.010 39.978	12.00 11.95	5	4	70	81	83	295	392	116	83	166	M12 x 1.75	25***	210	420	104	206	1/2 Inch
101M	50.010 49.978	14.00 13.95	5.5	4	90	100	103	380	501	134	102	204	M16 x 2	24	275	550	120	240	1/2 Inch
120M	60.010 59.978	18.00 17.95	7	4	110	122	121	425	581	167	115	230	M20 x 2.5	30	320	640	157	314	1/2 Inch

NOTE: SP = SPIRAL BEVEL GEARING

\*\* CROSS SHAFT ON 66M 1:1.53 SPIRAL INCREASER IS 28.008 - 27.981.

\*\* CROSS SHAFT ON 66M 1:2 SPIRAL INCREASER IS 25.008 - 24.981.

\* CROSS SHAFT ON 165M 1:2 SPIRAL INCREASER IS 15.008 - 14.981.

\*\*\* MOUNTING HOLE DEPTH ON 800M STYLE GG IS 19.





## MODELS 175M, 65M, 850M, 105M, 125M

### FEATURES

- Metric mounting dimensions, hardware, bearings and seals.
- Additional features listed on pages referenced below.
- Available ratios:
  - 175M 1:1SP, 1.5:1SP, 2:1SP, 3:1SP
  - 65M 1:1SP, 1.53:1SP, 2:1SP, 3:1SP
  - 850M 1:1SP, 1.5:1SP, 2:1SP, 3:1SP
  - 105M 1:1SP, 1.5:1SP, 2:1SP
  - 125M 1:1SP, 1.5:1SP, 2:1SP, 3:1SP
- Ratings and Assembly styles refer to the following pages:
 

175M Pages D-22, D-23	105M Pages D-40, D-41
65M Pages D-26, D-27	125M Pages D-44, D-45
850M Pages D-34, D-35	

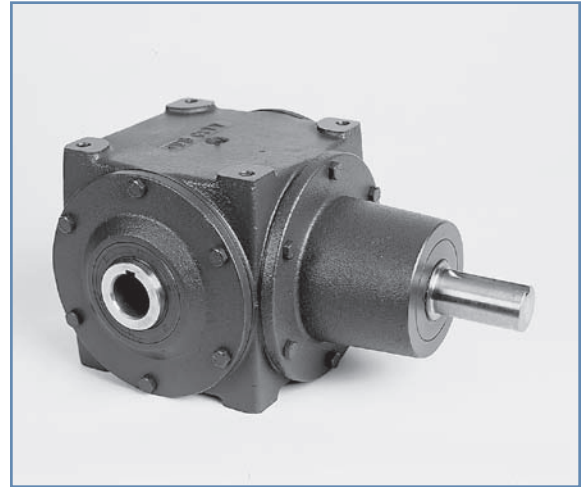

### FOR LUBRICATION AND INSTALLATION INSTRUCTIONS - REFER TO SECTION R

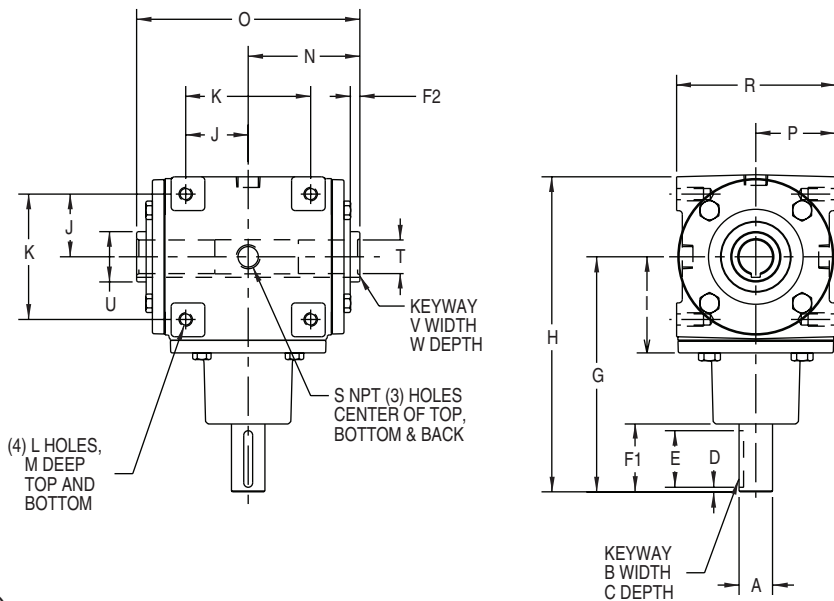

### DIMENSIONS (mm)

MODEL	A	B	C	D	E	F1	F2	G	H	I	J	K	L	M	N	O	P	R	S	T	U	V	W
<b>175M</b>	25.008 24.981	8.00 7.95	4	4	45	55	6	185	250	72	54	108	M8 x 1.25	16	80	160	53	106	1/4 Inch	25.000 25.063	38	8.00 8.05	3.3
<b>65M</b>	30.008 29.981	8.00 7.95	4	4	50	61	9	210	281	86	56	112	M12 x 1.75	24	100	200	71	142	1/2 Inch	30.000 30.063	45	8.00 8.05	3.3
<b>850M</b>	40.010 39.978	12.00 11.95	5	4	70	81	8	295	392	116	83	166	M12 x 1.75	25*	135	270	104	208	1/2 Inch	40.000 40.063	60	12.00 12.05	3.3
<b>105M</b>	50.010 49.978	14.00 13.95	5.5	4	90	100	11	380	501	134	102	204	M16 x 2	24	183	365	120	240	1/2 Inch	50.000 50.075	75	14.00 14.05	3.8
<b>125M</b>	60.010 59.978	18.00 17.95	7	4	110	122	10	425	581	167	115	230	M20 x 2.5	30	198	395	157	314	1/2 Inch	60.000 60.075	90	18.00 18.05	4.4

NOTE: SP = SPIRAL BEVEL GEARING

\* MOUNTING HOLE DEPTH ON 850M STYLE GG IS 19.



## MODEL RA-0

### FEATURES

- Rugged cast iron housing designed for rigid gear and bearing support.
- Alloy shafting for greater strength.
- Ball bearings for endurance and strength.
- Choice of three (3) standard gear ratios.
- Heavy-duty industrial seals to keep lubricant in and dirt out.
- Factory Filled with EP-4 Gear Oil.

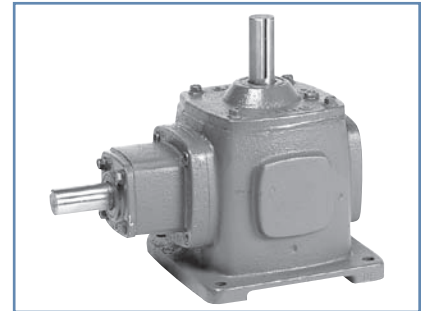

SHIPPING WEIGHT 13 LBS.

Output Shaft Overhung Load = 90 lbs, Located 0.75 inches From End of Shaft Extension.

Input Shaft Overhung Load = 60 lbs, Located 0.75 inches From End of Shaft Extension.

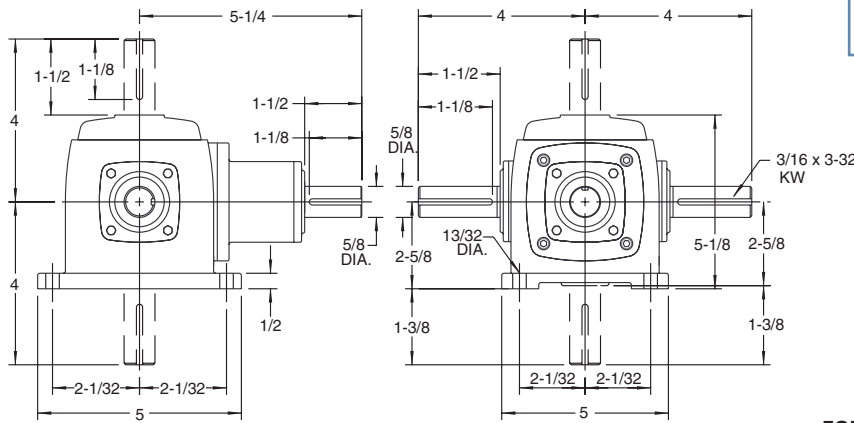

FOR LUBRICATION AND INSTALLATION INSTRUCTIONS - REFER TO SECTION R

### RATINGS

INPUT RPM		REDUCTION RATIOS			INCREASER RATIOS	
		1:01	2:1	3:1	1:2	1:3
1750	INPUT HORSEPOWER	2.00	2.50	1.70	-	-
	OUTPUT TORQUE (IN-LBS)	72.0	180	184	-	-
1150	INPUT HORSEPOWER	1.50	1.90	1.30	-	-
	OUTPUT TORQUE (IN-LBS)	82.2	208	214	-	-
850	INPUT HORSEPOWER	1.20	1.50	1.00	2.70	-
	OUTPUT TORQUE (IN-LBS)	89.0	222	222	100	-
690	INPUT HORSEPOWER	1.00	1.30	0.93	2.35	2.56
	OUTPUT TORQUE (IN-LBS)	91.3	237	255	107	77.72
540	INPUT HORSEPOWER	0.90	1.10	0.79	2.00	2.18
	OUTPUT TORQUE (IN-LBS)	105	257	277	117	85.06
300	INPUT HORSEPOWER	0.60	0.70	0.50	1.29	1.41
	OUTPUT TORQUE (IN-LBS)	126	294	315	135	97.83
100	INPUT HORSEPOWER	0.25	0.30	0.20	0.56	0.57
	OUTPUT TORQUE (IN-LBS)	158	378	378	175	120.02

### ASSEMBLIES

ROTATIONS SHOWN ARE FOR STANDARD ROTATION - SR  
FOR OPPOSITE OUTPUT ROTATION, ORDER REVERSE ROTATION - RR.

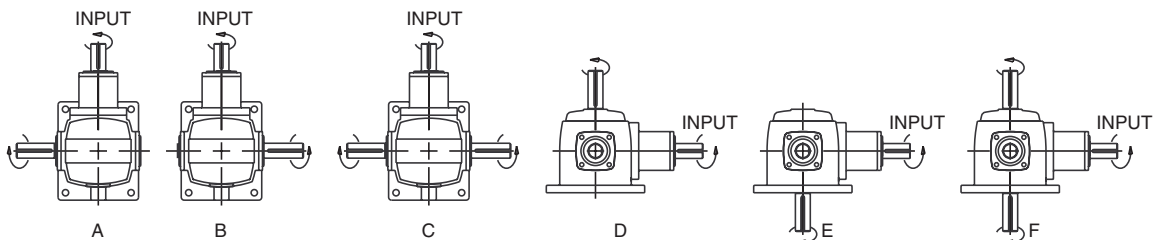

IN ADDITION TO ASSEMBLY STYLE, SPECIFY MOUNTING POSITION WHEN ORDERING-SEE PAGE D-64.



# MODEL RA-1

## FEATURES

- Rugged cast iron housing designed for rigid gear and bearing support.
- Alloy shafting for greater strength.
- Tapered roller bearings for endurance and strength.
- Choice of three (3) standard gear ratios.
- Heavy-duty industrial seals to keep lubricant in and dirt out.
- Factory Filled with EP-4 Gear Oil.

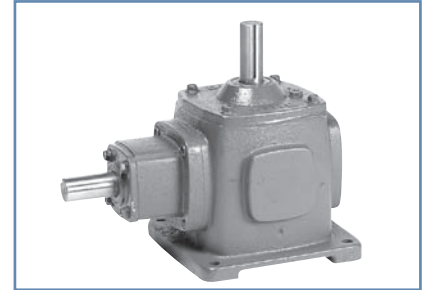

SHIPPING WEIGHT 28 LBS.

**Output Shaft Overhung Load = 200 lbs, Located 1.36 inches From End of Shaft Extension.**

**Input Shaft Overhung Load = 135 lbs, Located 0.94 inches From End of Shaft Extension.**

**FOR LUBRICATION AND INSTALLATION INSTRUCTIONS - REFER TO SECTION R**

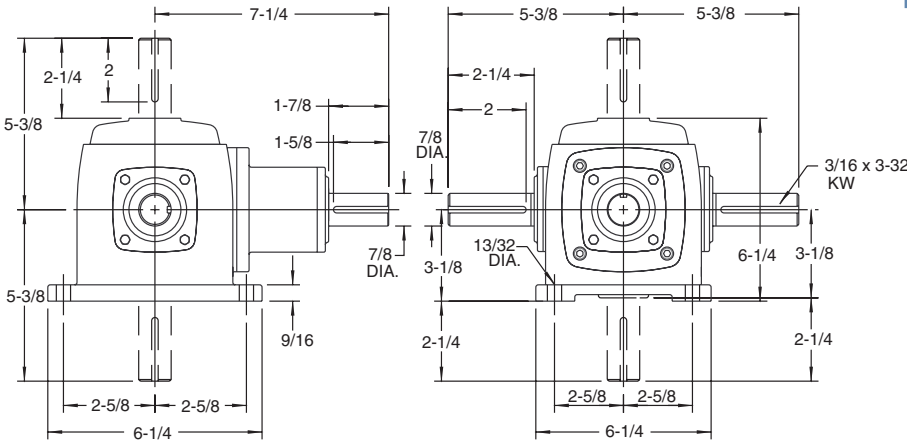

## RATINGS

INPUT RPM		REDUCTION RATIOS			INCREASER RATIO
		SPIRAL 1:01	SPIRAL 2:1	SPIRAL 3:1	SPIRAL 1:2
3000	INPUT HORSEPOWER	20.60	15.00	10.60	-
	OUTPUT TORQUE (IN-LBS)	433	630	668	-
2400	INPUT HORSEPOWER	17.60	12.80	8.70	-
	OUTPUT TORQUE (IN-LBS)	462	672	685	-
1750	INPUT HORSEPOWER	14.10	10.30	6.50	-
	OUTPUT TORQUE (IN-LBS)	508	742	702	-
1150	INPUT HORSEPOWER	10.50	7.50	4.50	13.96
	OUTPUT TORQUE (IN-LBS)	575	822	740	382
850	INPUT HORSEPOWER	8.50	5.70	3.40	10.68
	OUTPUT TORQUE (IN-LBS)	630	845	756	396
690	INPUT HORSEPOWER	7.30	4.70	2.80	8.83
	OUTPUT TORQUE (IN-LBS)	667	859	767	404
540	INPUT HORSEPOWER	6.00	3.80	2.20	7.18
	OUTPUT TORQUE (IN-LBS)	700	887	770	419
300	INPUT HORSEPOWER	3.50	2.20	1.30	4.19
	OUTPUT TORQUE (IN-LBS)	735	924	819	441
100	INPUT HORSEPOWER	1.30	0.77	0.45	1.49
	OUTPUT TORQUE (IN-LBS)	819	971	851	469

## ASSEMBLIES

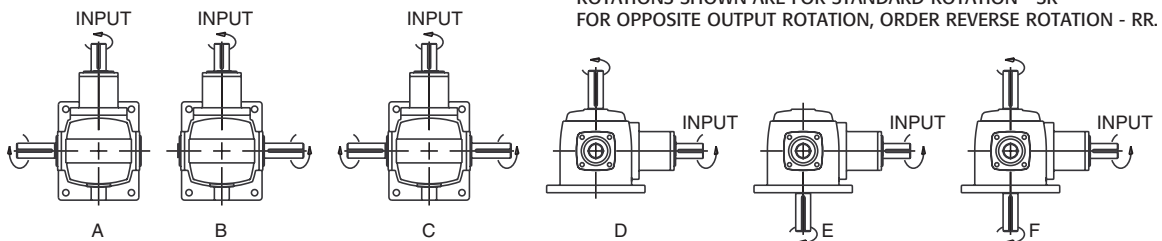

ROTATIONS SHOWN ARE FOR STANDARD ROTATION - SR FOR OPPOSITE OUTPUT ROTATION, ORDER REVERSE ROTATION - RR.

IN ADDITION TO ASSEMBLY STYLE, SPECIFY MOUNTING POSITION WHEN ORDERING-SEE PAGE D-64.



# MODEL RA-2

## FEATURES

- Rugged cast iron housing designed for rigid gear and bearing support.
- Alloy shafting for greater strength.
- Tapered roller bearings for endurance and strength.
- Choice of three (3) standard gear ratios.
- Heavy-duty industrial seals to keep lubricant in and dirt out.
- Factory Filled with EP-4 Gear Oil.



SHIPPING WEIGHT 40 LBS.

**Output Shaft Overhung Load = 400 lbs, Located 1.93 inches From End of Shaft Extension.**

**Input Shaft Overhung Load = 270 lbs, Located 1.16 inches From End of Shaft Extension.**

**FOR LUBRICATION AND INSTALLATION INSTRUCTIONS - REFER TO SECTION R**

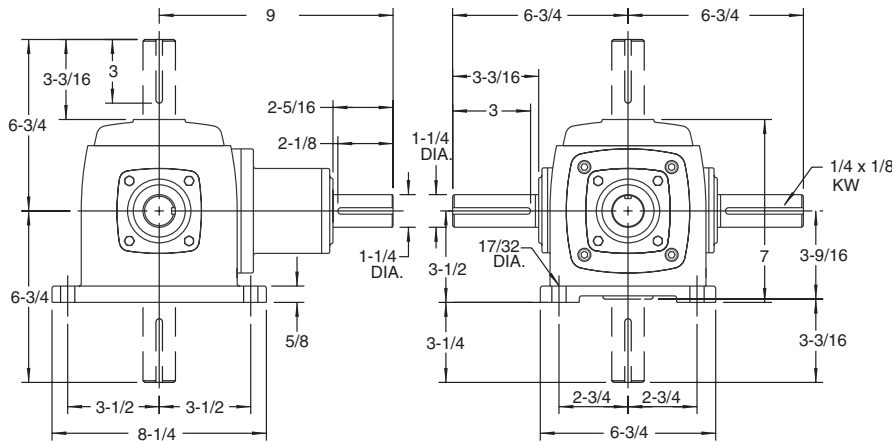

D  
RATING AND DIMENSIONS

## RATINGS

INPUT RPM		REDUCTION RATIOS			INCREASER RATIO
		SPIRAL 1:1	SPIRAL 2:1	SPIRAL 3:1	SPIRAL 1:2
2400	INPUT HORSEPOWER	27.30	19.10	16.30	-
	OUTPUT TORQUE (IN-LBS)	717	1003	1284	-
1750	INPUT HORSEPOWER	21.90	15.30	13.10	-
	OUTPUT TORQUE (IN-LBS)	789	1102	1415	-
1150	INPUT HORSEPOWER	16.30	10.90	9.70	20.22
	OUTPUT TORQUE (IN-LBS)	893	1195	1595	554
850	INPUT HORSEPOWER	13.20	8.30	7.40	15.49
	OUTPUT TORQUE (IN-LBS)	979	1231	1646	575
690	INPUT HORSEPOWER	11.40	6.90	6.10	12.94
	OUTPUT TORQUE (IN-LBS)	1041	1261	1672	591
540	INPUT HORSEPOWER	9.60	5.50	4.80	10.36
	OUTPUT TORQUE (IN-LBS)	1120	1284	1681	605
300	INPUT HORSEPOWER	6.10	3.20	2.80	6.10
	OUTPUT TORQUE (IN-LBS)	1282	1345	1765	640
100	INPUT HORSEPOWER	2.20	1.10	1.00	2.13
	OUTPUT TORQUE (IN-LBS)	1387	1387	1891	670

CROSS SHAFT REDUCTION RATIOS		
DIMENSION	SPIRAL 1:1	SPIRAL 2:1
DIA. X	1.250	1.249
KEYWAY Z	1/4 X 1/8 X 3.00 P&W KW	

CROSS SHAFT INCREASER RATIOS		
DIMENSION	SPIRAL 1:2 STYLE A, B, C, D, E	SPIRAL 1:2 STYLE C, F
DIA. X	1.250 1.249	.750 .749
KEYWAY Z	1/4 X 1/8 X 3.00 P&W KW	3/16 X 3/32 X 3.00 P&W KW

## ASSEMBLIES

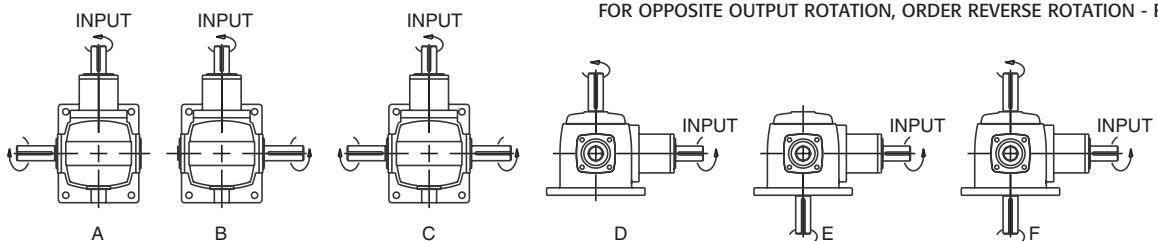

ROTATIONS SHOWN ARE FOR STANDARD ROTATION - SR  
FOR OPPOSITE OUTPUT ROTATION, ORDER REVERSE ROTATION - RR.

IN ADDITION TO ASSEMBLY STYLE, SPECIFY MOUNTING POSITION WHEN ORDERING-SEE PAGE D-64.

CALL: (605) 225-0360 • FAX: (605) 225-0567



## MODEL RA-3

### FEATURES

- Rugged cast iron housing designed for rigid gear and bearing support.
- Alloy shafting for greater strength.
- Tapered roller bearings for endurance and strength.
- Choice of three (3) standard gear ratios.
- Heavy-duty industrial seals to keep lubricant in and dirt out.
- Factory Filled with EP-4 Gear Oil.

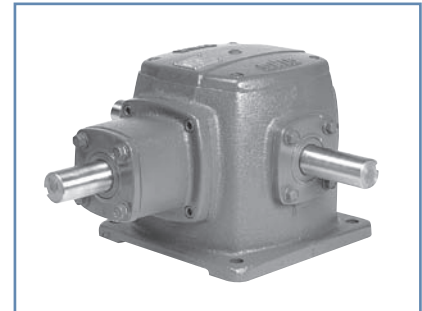

SHIPPING WEIGHT 85 LBS.

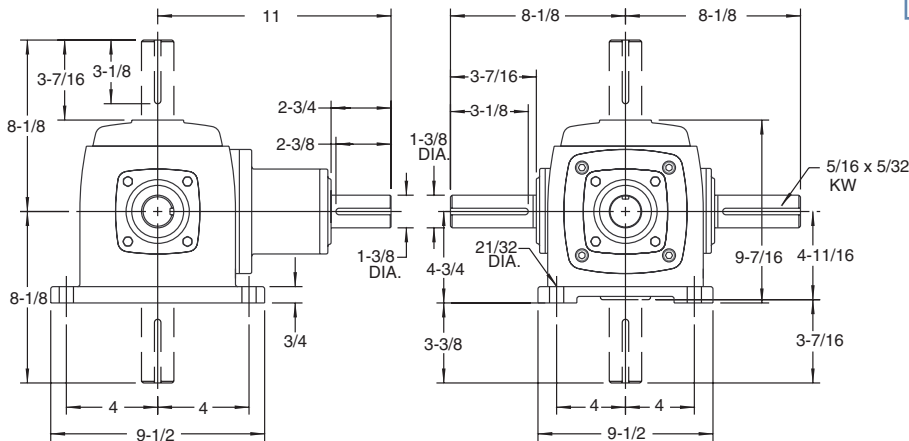

**Output Shaft Overhung Load = 600 lbs, Located 2.07 inches From End of Shaft Extension.**

**Input Shaft Overhung Load = 400 lbs, Located 1.37 inches From End of Shaft Extension.**

**FOR LUBRICATION AND INSTALLATION INSTRUCTIONS - REFER TO SECTION R**

### RATINGS

INPUT RPM		REDUCTION RATIOS			INCREASER RATIO
		SPIRAL 1:1	SPIRAL 2:1	SPIRAL 3:1	SPIRAL 1:2
2400	INPUT HORSEPOWER	51.3	49.6	35.2	-
	OUTPUT TORQUE (IN-LBS)	1347	2605	2773	-
1750	INPUT HORSEPOWER	41.1	39.6	27.3	-
	OUTPUT TORQUE (IN-LBS)	1480	2852	2950	-
1150	INPUT HORSEPOWER	30.0	27.3	18.7	50.2
	OUTPUT TORQUE (IN-LBS)	1644	2992	3075	1376
850	INPUT HORSEPOWER	22.7	20.9	14.2	38.7
	OUTPUT TORQUE (IN-LBS)	1683	3099	3159	1435
690	INPUT HORSEPOWER	18.8	17.3	11.8	32.0
	OUTPUT TORQUE (IN-LBS)	1717	3160	3233	1470
540	INPUT HORSEPOWER	15.1	13.8	9.4	25.87
	OUTPUT TORQUE (IN-LBS)	1762	3221	3291	1507
300	INPUT HORSEPOWER	8.8	8.0	5.4	15.13
	OUTPUT TORQUE (IN-LBS)	1849	3361	3403	1590
100	INPUT HORSEPOWER	3.2	2.9	1.9	5.57
	OUTPUT TORQUE (IN-LBS)	2017	3656	3592	1757

### ASSEMBLIES

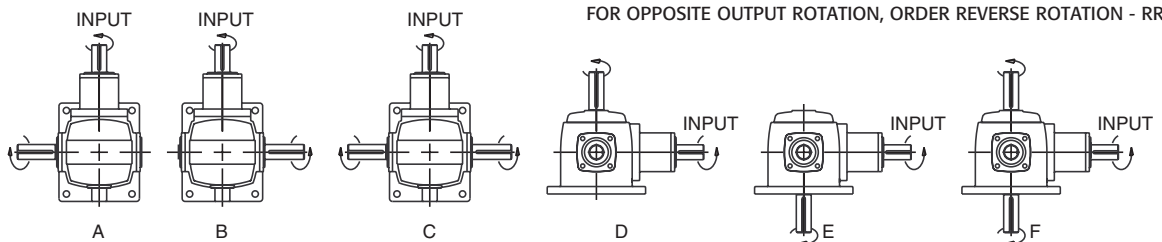

ROTATIONS SHOWN ARE FOR STANDARD ROTATION - SR  
FOR OPPOSITE OUTPUT ROTATION, ORDER REVERSE ROTATION - RR.

IN ADDITION TO ASSEMBLY STYLE, SPECIFY MOUNTING POSITION WHEN ORDERING-SEE PAGE D-64.



# MODEL RA-4

## FEATURES

- Rugged cast iron housing designed for rigid gear and bearing support.
- Alloy shafting for greater strength.
- Tapered roller bearings for endurance and strength.
- Choice of three (3) standard gear ratios.
- Heavy-duty industrial seals to keep lubricant in and dirt out.
- Factory Filled with EP-4 Gear Oil.

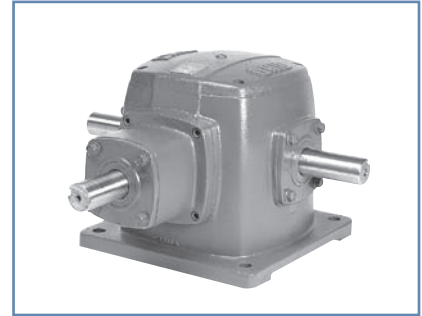

SHIPPING WEIGHT 140 LBS.

**Output Shaft Overhung Load = 800 lbs, Located 2.25 inches From End of Shaft Extension.**

**Input Shaft Overhung Load = 550 lbs, Located 1.56 inches From End of Shaft Extension.**

**Heavy Duty Version with 1-3/4 Dia. Shafts Available, Consult Factory.**

**FOR LUBRICATION AND INSTALLATION INSTRUCTIONS - REFER TO SECTION R**

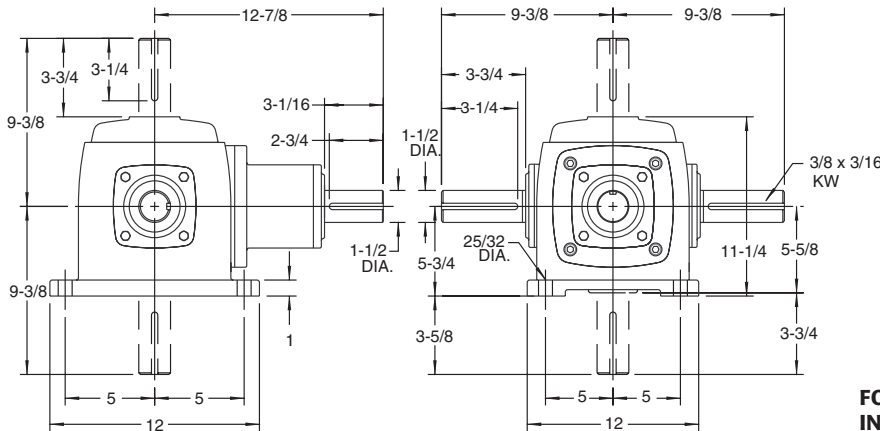

## RATINGS

INPUT RPM		REDUCTION RATIOS			INCREASER RATIOS	
		SPIRAL 1:1	SPIRAL 2:1	SPIRAL 3:1	SPIRAL 1:2	SPIRAL 1:3
1750	INPUT HORSEPOWER	52.2	49.5	40.2	-	-
	OUTPUT TORQUE (IN-LBS)	1880	3565	4343	-	-
1150	INPUT HORSEPOWER	38.9	36.9	30.0	-	-
	OUTPUT TORQUE (IN-LBS)	2132	4045	4932	-	-
850	INPUT HORSEPOWER	31.5	29.8	24.2	55.0	-
	OUTPUT TORQUE (IN-LBS)	2336	4419	5383	2037	-
690	INPUT HORSEPOWER	27.2	25.8	20.9	47.8	38.8
	OUTPUT TORQUE (IN-LBS)	2484	4713	5727	2184	1773
540	INPUT HORSEPOWER	22.9	21.7	17.6	40.4	32.9
	OUTPUT TORQUE (IN-LBS)	2673	5065	6162	2359	1918
300	INPUT HORSEPOWER	14.4	14.4	10.5	27.1	19.8
	OUTPUT TORQUE (IN-LBS)	3025	6050	6627	2851	2086
100	INPUT HORSEPOWER	5.2	5.3	3.5	10.2	6.7
	OUTPUT TORQUE (IN-LBS)	3277	6627	6627	3177	2121

CROSS SHAFT REDUCTION RATIOS			
DIMENSION	SPIRAL 1:1	SPIRAL 2:1	SPIRAL 3:1
DIA. X	1.250 1.249		
KEYWAY Z	3/8 X 3/16 X 3.25 P&W KW		

CROSS SHAFT INCREASER RATIOS			
DIMENSION	SPIRAL 1:2 STYLE	SPIRAL 1:2 A, B, D, E	SPIRAL 1:3 C, F
DIA. X	1.500 1.499		1.187 1.186
KEYWAY Z	3/8 X 3/16 X 3.25 P&W KW		1/4 X 1/8 X 3.25 P&W

## ASSEMBLIES

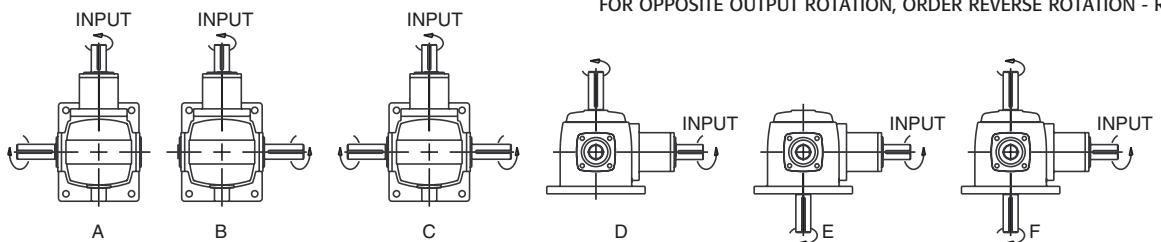

ROTATIONS SHOWN ARE FOR STANDARD ROTATION - SR  
FOR OPPOSITE OUTPUT ROTATION, ORDER REVERSE ROTATION - RR.

IN ADDITION TO ASSEMBLY STYLE, SPECIFY MOUNTING POSITION WHEN ORDERING-SEE PAGE D-64.



## RA MOUNTING POSITIONS

ASSEMBLIES			
A, B, & C	<p>M1 FLOOR MOUNT</p>	<p>M2 CEILING MOUNT</p>	<p>M3 WALL MOUNT</p>
ASSEMBLIES			
A, B, & C	<p>M4 WALL MOUNT</p>	<p>M5 WALL MOUNT</p>	<p>M6 WALL MOUNT</p>
ASSEMBLIES			
D, E, & F	<p>M1 FLOOR MOUNT</p>	<p>M2 CEILING MOUNT</p>	<p>M3 WALL MOUNT</p>
ASSEMBLIES			
D, E, & F	<p>M4 WALL MOUNT</p>	<p>M5 WALL MOUNT</p>	<p>M6 WALL MOUNT</p>





## ACCESSORIES AND FACTORY OPTIONS

### FOOT MOUNTING KIT (ACCESSORY)

MODELS 150, 165, 175

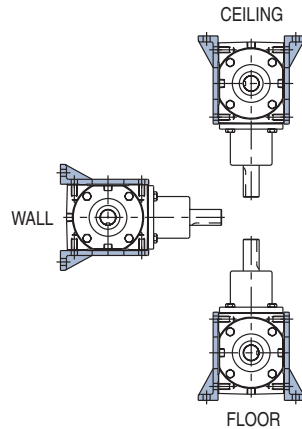

KIT NO. 0229-02068  
(KIT ONLY) WEIGHT 6-1/2 lbs.

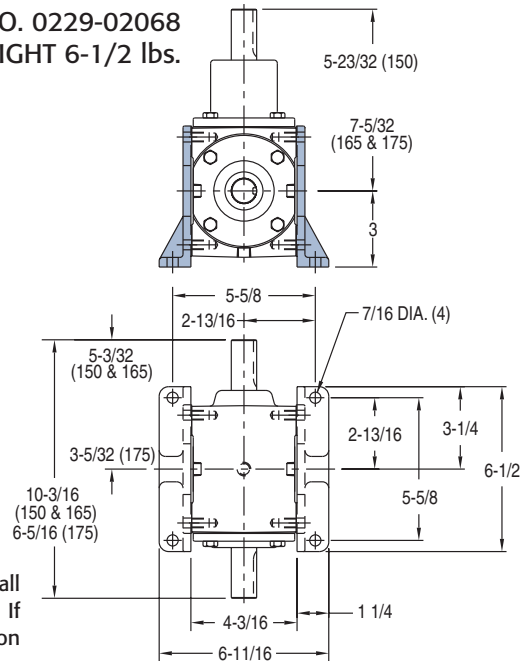

**FOOT MOUNTING KITS** are available as an accessory to provide ceiling, floor, or wall mounting with the pinion shaft positioned at right angle to the mounting surface. If any shaft is mounted in a vertical position, consult the factory for special lubrication instructions.

### BASE MOUNTING KIT (ACCESSORY)

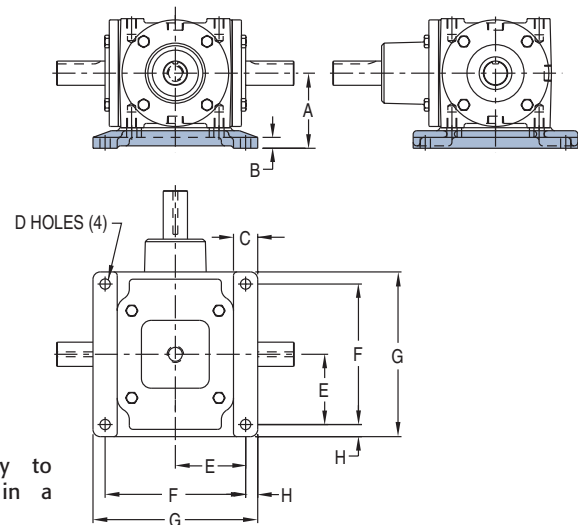
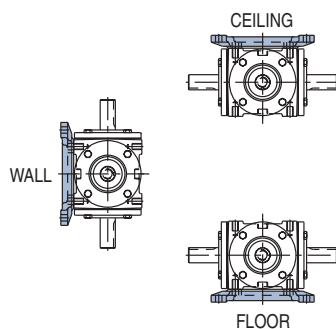

**BASE MOUNTING KITS** as illustrated is available as an accessory to provide ceiling, floor, or wall mounting. If any shaft is mounted in a vertical position, consult the factory for special lubrication instructions.

MODEL	A	B	C	D	E	F	G	H	PART NUMBER	WT. EA. LBS.
150, 165, 175	3	3/8	NA	7/16	2-13/16	5-5/8	6-1/2	7/16	0229-00008	8
66, 65, 600	3-7/8	9/16	1-1/4	17/32	3-5/8	7-1/4	8-1/2	5/8	0229-00011	15
88, 800, 810, 850	5-1/4	5/8	1-3/4	17/32	5	10	11-1/2	3/4	0229-00012	31
1000, 1010, 1050	6-1/8	3/4	1-3/4	17/32	5-3/4	11-1/2	13	3/4	0229-00013	40
1200, 1250	8	31/32	2-1/2	15/16	7	14	16-5/8	1-5/16	0229-00014	75



## ACCESSORIES AND FACTORY OPTIONS

### CROSS SHAFT MOUNTING (FACTORY OPTION)

MODELS 66, 600

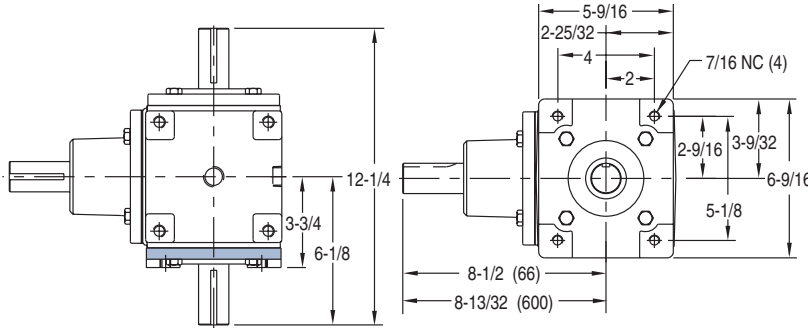

**CROSS SHAFT MOUNTING** is available as a **FACTORY OPTION** to provide a mounting face on the shaft side of the gear drive. The Mounting Flange also serves as the bearing cap and is factory installed. If any shaft is mounted in a vertical position, consult the factory for special lubrication instructions.

### PINION SHAFT MOUNTING KIT (FACTORY OPTION)

MODELS 66, 65, 600, 88, 800, 810, 850

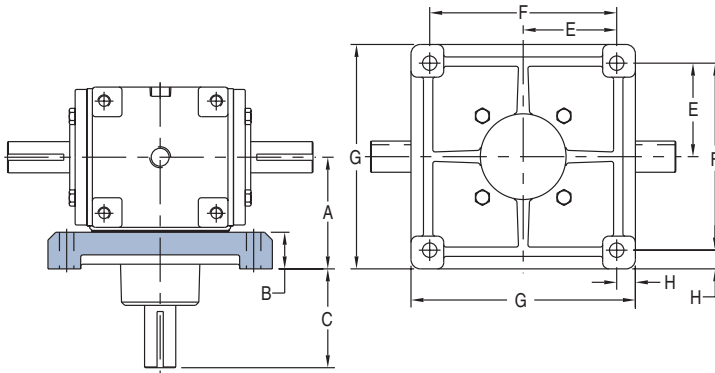

**PINION SHAFT MOUNTING KIT** is available as a **FACTORY OPTION** to provide a mounting flange on the pinion face of the gear drive. If any shaft is mounted in a vertical position, consult the factory for special lubrication instructions.

MODEL	A	B	C	D	E	F	G	H	WT. EA. LBS.
66, 65, 600	4-1/2	1-15/32	$\frac{3-15/16 (66, 65)}{3-29/32 (600)}$	37/64	3-3/4	7-1/2	9	3/4	18
88, 800, 810, 850	5-1/2	1-1/16	$\frac{5-3/8 (88)}{6 (800, 810, 850)}$	37/64	5	10	11-1/4	5/8	31

### REVERSING SHIFT MECHANISM

MODELS 66R, 88R (FACTORY OPTION)

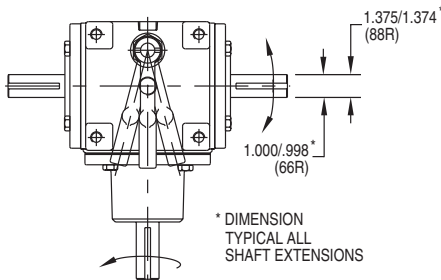

For output shaft change of rotation.

1. FORWARD
2. NEUTRAL
3. REVERSE

MODEL	RATIOS AVAILABLE			
	1:1	1.5:1	2:1	3:1
66R	X	X	X	
88R	X	X	X	X

**NOTE:** REVERSING UNITS ARE DESIGNED FOR LIGHT DUTY APPLICATIONS. THE RATINGS FOR REVERSING UNITS ARE LESS THAN THE RATINGS FOR THE STANDARD UNITS SHOWN ON PAGES D-24 AND D-30.



## MODELS 165, 175, 66, 65, 600, 88, 800, 850 HYDRAULIC MOTOR MOUNTS

### HYDRAULIC MOTOR MOUNTING (FACTORY OPTION)

HYDRAULIC MOTOR MOUNTS ARE AVAILABLE AS SHOWN IN THE CHART BELOW. HYDRAULIC MOTOR MOUNTS ARE AVAILABLE ONLY AS FACTORY OPTIONS. FOR ADDITIONAL INFORMATION AND DIMENSIONS CONTACT HUB CITY CUSTOMER SERVICE. ENGINEERING DRAWINGS OF THESE UNITS ARE AVAILABLE UPON REQUEST.

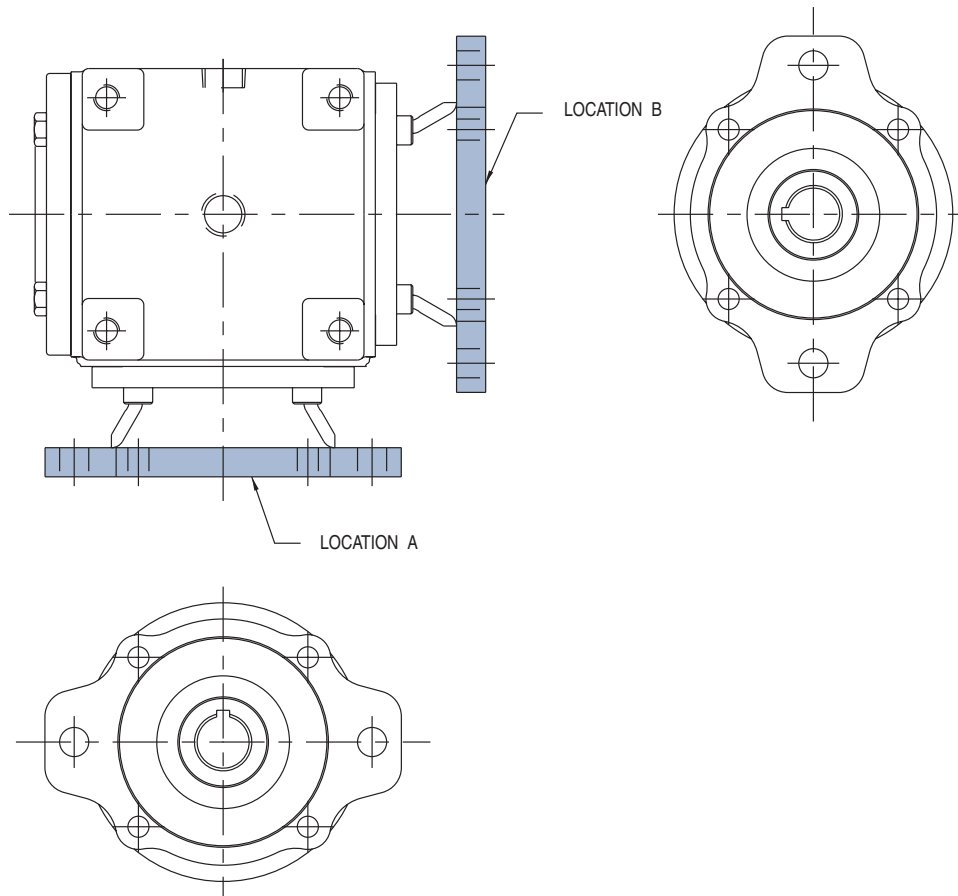

### HYDRAULIC MOTOR MOUNTS AVAILABLE

MODEL	SAE A (2) Hole Female Location A	SAE A (4) Hole Female Location A	SAE B (2) or (4) Hole Female Location A	SAE B (2) or (4) Hole Female Location B	SAE B (2) or (4) Hole Male Location A	SAE C (2) Hole Female Location A	SAE C (4) Hole Female Location A	SAE C (4) Hole Female Location A
165, 175	X	Not Available	Not Available	Not Available	Not Available	Not Available	Not Available	Not Available
66, 65, 600	X	X	X	X	X	Not Available	X	X
88, 800, 850	Not Available	Not Available	X	X (2) Hole Only	Not Available	X	Not Available	Not Available

HYDRAULIC MOTOR MOUNTS LISTED AS NOT AVAILABLE CAN BE MANUFACTURED ON A SPECIAL ORDER BASIS.



## **FACTORY OPTIONS**

The following factory options are available for gear drives in this catalog. Contact the factory for details on price, availability, and specifications.

### **CLEANLINE™ (REFER TO SECTION O)**

When application conditions demand premium washdown duty gear drives.

#### **FEATURES**

FDA approved white acrylic paint  
Corrosion resistant shaft treatment or stainless steel shafts  
Stainless steel hardware and nameplate

#### **OPTIONS**

BISSC Standards

### **METRIC VERSIONS (SEE PAGES D-56 THRU D-58)**

#### **FEATURES**

Metric shaft dimensions  
Metric mounting dimensions

#### **OPTIONS**

Modified and Custom Designs

### **C-FACE MOTOR FLANGES**

Motor Flanges are available for select models of Bevel Gear Drives. Motor Flanges must be factory assembled.

### **MODIFIED AND CUSTOM DESIGNS**

If you have looked through this catalog and do not see exactly what you need, Hub City has the capability and engineering expertise to design and produce a special drive. Capabilities range from flange and shaft modifications, to custom housing dimensions. Consult the factory or your Hub City representative with your specifications.