



GC24003 Shown
FTA Style

Applications: General purpose fixed speed including conveyors, material handling equipment and packaging machinery.

Features: PSC motor design providing 100% starting torque. High strength bronze gearing, hardened and ground worm for quiet operation. High performance low friction, bidirectional motor seals. Factory lubricated with synthetic grease, no routine maintenance is required. Can be mounted in all positions including vertical motor below gearbox.

Input Motor Hp	Output RPM 50/60 Hz	Gear Ratio	Max. Safe Torque In. Lbs.	Catalog Number	List Price	Mult. Sym.	Ap'x. Shpg. Wgt.	Motor Type & Gear Style	Enclosure	Voltage	Notes (b)
Single Phase											
1/50	59/71.4	24:1	7.5	GC24003	338	DS	7	2412C-FTA	TENV	115	19,20

(b) See notes on inside back flap and pages 5-6.

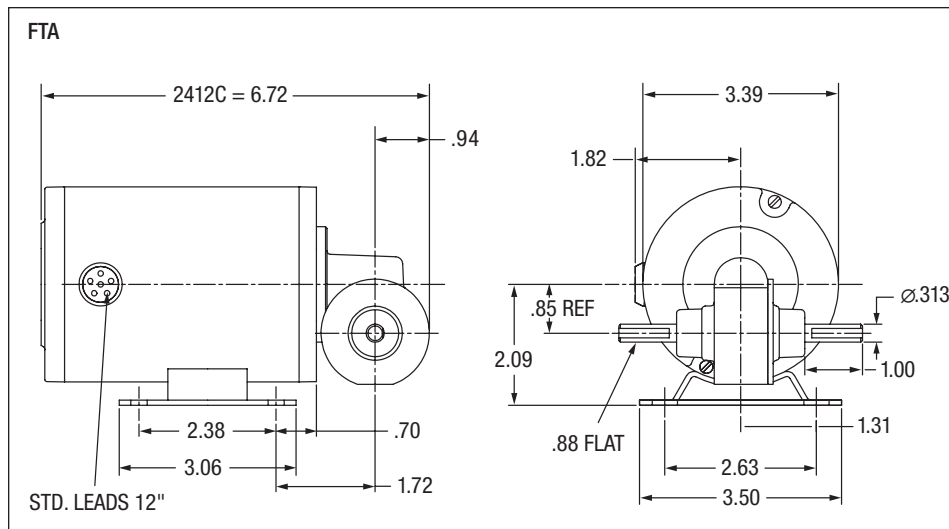



GC24208 Shown
DB Style

Applications: General purpose fixed speed including conveyors, material handling equipment and packaging machinery.

Features: PSC motor design provides 100% starting torque. High strength bronze gearing, hardened and ground worm for quiet operation. High performance low friction, bidirectional motor seals. Factory lubricated for life, no maintenance required. Internal oil expansion bladder allows for multiple mounting positions, without relocating a bladder vent.

Input Motor Hp	Output RPM 50/60 Hz	Gear Ratio	Max. Safe Torque In. Lbs.	Catalog Number ^(a)	List Price	Mult. Sym.	Ap'x. Shpg. Wgt.	Motor Type & Gear Style	Enclosure	Voltage	Notes ^(b)
Single Phase											
1/40	11.8/14	117:1	40	GC24208	449	DS	10	2412C-DB	TENV	115	19,20,78

^(a) Vertical motor below gearhead not recommended.

Avoiding those positions where the high speed oil seal is immersed in oil, will provide greater security against high speed input seal wear.

^(b) See notes on inside back flap and pages 5-6.

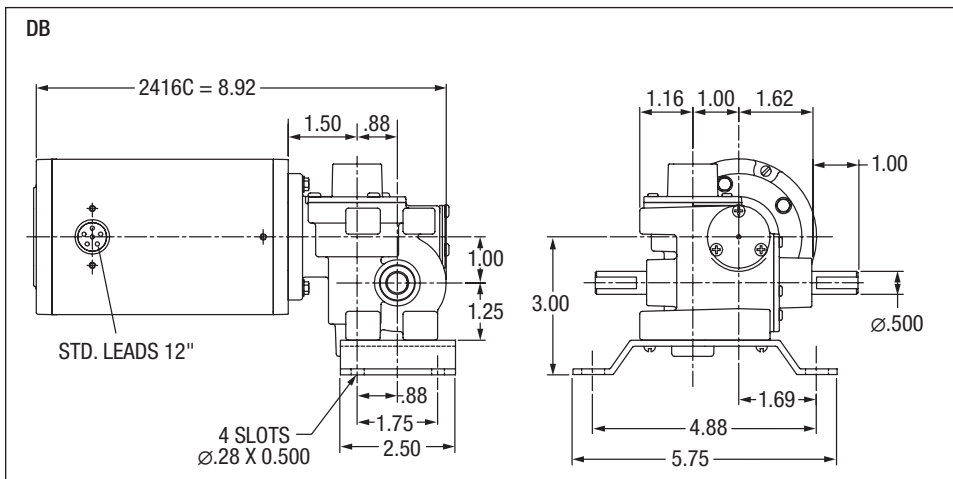



Applications: General purpose fixed speed including conveyors, material handling equipment and packaging machinery.

Features: Three and single-phase motor designs. High strength bronze gearing, hardened and ground worm for quiet operation. High performance low friction, bidirectional motor seals. Factory lubricated for life, no maintenance required. Internal oil expansion bladder allows for multiple mounting positions, without relocating a breather vent.

GC24314 Shown
EB Style

Input Motor Hp	Output RPM 50/60 Hz	Gear Ratio	Max. Safe Torque In. Lbs.	Catalog Number ^(a)	List Price	Mult. Sym.	Ap'x. Shpg. Wgt.	Motor Type & Gear Style	Enclosure	Voltage	Notes ^(b)	Drawing Number
Single Phase												
1/13	7.7/9.3	180:1	175	GC24314	575	DS	10	2416C-EB	TENV	115	19,20,78	1
1/20	12.7/16	100:1	100	GC24312	575	DS	10	2416C-EB	TENV	115	19,20,78	1
Three Phase												
1/12	1.5	1200:1	175	GM25021	608	DS	15	2516M-EB	TENV	208/230-460	20,33	2
	11.3	150:1	125	GM25016	608	DS	15	2516M-EB	TENV	208/230-460	20,33	2

^(a) Vertical motor below gearhead not recommended.
Avoiding those positions where the high speed oil seal is immersed in oil, will provide greater security against high speed input seal wear.

^(b) See notes on inside back flap and pages 5-6.

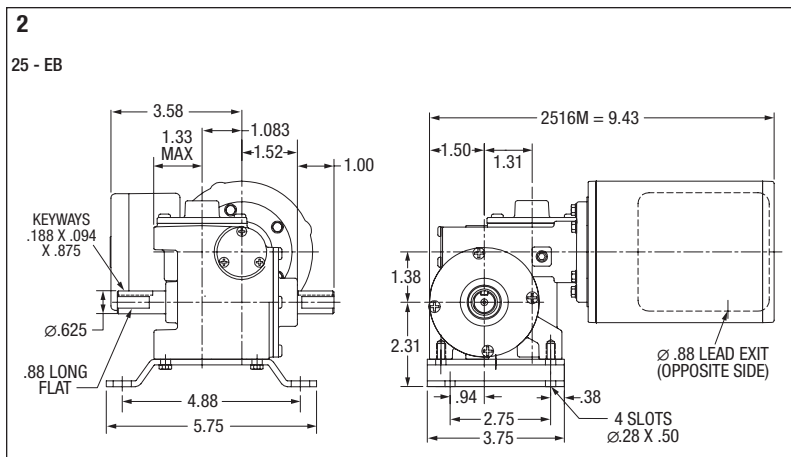
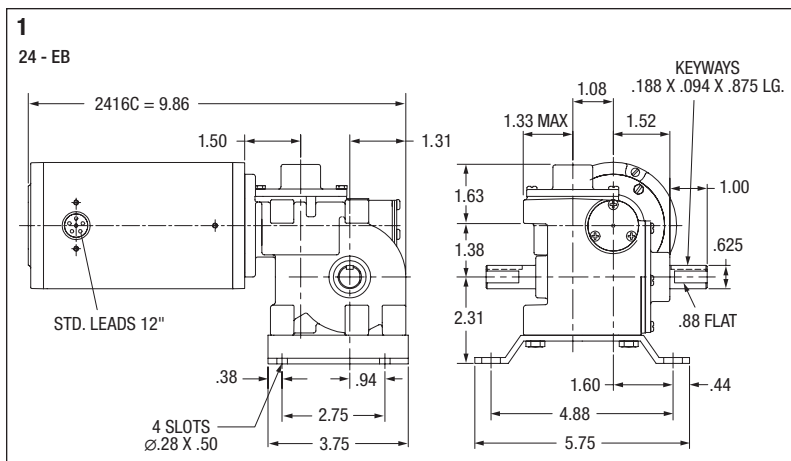



GC25280 Shown
G Style

Applications: General purpose fixed speed including conveyors, material handling equipment and packaging machinery.

Features: Three and single-phase motor designs. PSC, single-phase gearmotors supplied with capacitor and conduit box. High strength bronze, ground worm first-stage and helical output stage. High performance low friction, bidirectional motor seals. Factory lubricated for life, no maintenance required. Completely sealed from the environment.

Input Motor Hp	Output RPM 60 Hz	Gear Ratio	Max. Safe Torque In. Lbs.	Catalog Number ^(a)	List Price	Mult. Sym.	Ap'x. Shpg. Wgt.	Motor Type & Gear Style	Enclosure	Voltage	Notes ^(b)
Single Phase											
1/6	4.9/5.9	280:1	400	GC25280	734	DS	15	2520C-G	TEFC	115	19,20
	7.4/8.9	190:1	385	GC25190	734	DS	15	2520C-G	TEFC	115	19,20
	11.6/14	120:1	300	GC25120	734	DS	15	2520C-G	TEFC	115	19,20
	17.5/21	80:1	290	GC25080	734	DS	15	2520C-G	TEFC	115	19,20
	23/28	60:1	220	GC25060	734	DS	15	2520C-G	TEFC	115	19,20
Three Phase											
1/6	4.9/5.9	280:1	400	GM25280	799	DS	12	2516M-G	TEFC	190/380//230/460	19,20
	7.3/8.9	190:1	385	GM25190	799	DS	12	2516M-G	TEFC	190/380//230/460	19,20
	11.3/13.3	120:1	300	GM25120	799	DS	10	2516M-G	TEFC	190/380//230/460	19,20
	16.5/20.4	80:1	310	GM25080	799	DS	12	2516M-G	TEFC	190/380//230/460	19,20
	22.5/27.5	60:1	250	GM25060	799	DS	12	2516M-G	TEFC	190/380//230/460	19,20

^(a) Vertical motor below gearhead not recommended.

Avoiding those positions where the high speed oil seal is immersed in oil, will provide greater security against high speed input seal wear.

^(b) See notes on inside back flap and pages 5-6.

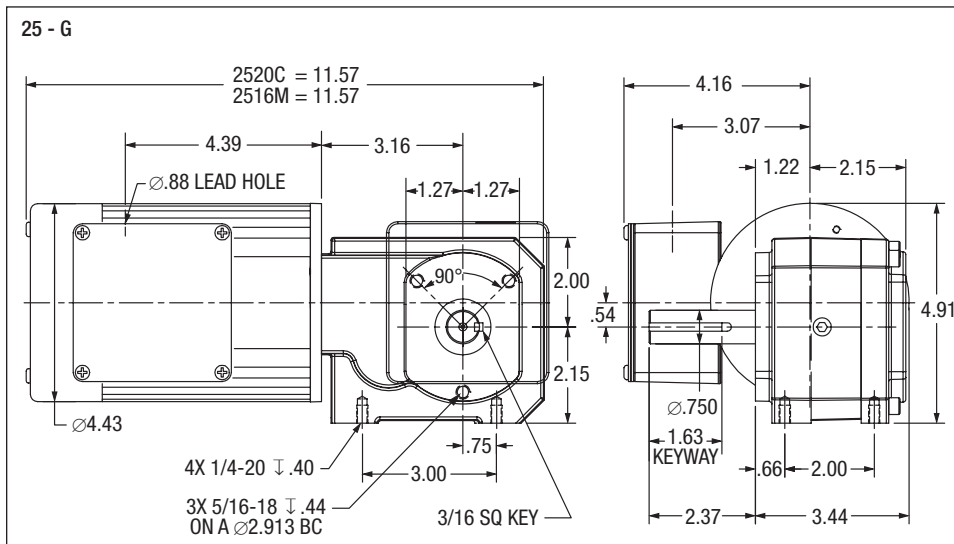



GC24307 Shown
KA Style

Applications: General purpose fixed speed including conveyors, material handling equipment and packaging machinery.

Features: Three and single-phase motor designs. High strength bronze gearing, hardened and ground worm for quiet operation. High performance low friction, bidirectional motor seals. Factory lubricated for life, no maintenance required. Internal oil expansion bladder allows for multiple mounting positions, without relocating a breather vent.

Input Motor Hp	Output RPM 50/60 Hz	Gear Ratio	Max. Safe Torque In. Lbs.	Catalog Number ^(a)	List Price	Mult. Sym.	Ap'x. Shpg. Wgt.	Motor Type & Gear Style	Enclosure	Voltage	Notes ^(b)	Drawing Number	
Single Phase													
1/15	23/28	60:1	45	GC24307	448	DS	11	2416C-KA	TEFC	110//115	19,20	1	
	35/42	40:1	49	GC24308	448	DS	11	2416C-KA	TEFC	110//115	19,20	1	
	68/82.5	20:1	32	GC24309	448	DS	11	2416C-KA	TEFC	110//115	19,20	1	
	135/165	10:1	18	GC24311	448	DS	11	2416C-KA	TEFC	110//115	19,20	1	
1/8	34/41	40:1	90	GC25004	529	DS	16	2520C-KA	TEFC	110//115	19,20	2	
	46/55	30:1	78	GC25006	529	DS	16	2520C-KA	TEFC	110//115	19,20	2	
	69/82	20:1	57	GC25007	529	DS	16	2520C-KA	TEFC	110//115	19,20	2	
	130/160	10:1	33	GC25008	529	DS	16	2520C-KA	TEFC	110//115	19,20	2	
	36/43	40:1	90	GC25009	529	DS	15	2520S-KA	TEFC	110//115	19,20	2	
	48/57	30:1	78	GC25011	529	DS	15	2520S-KA	TEFC	110//115	19,20	2	
	71/86	20:1	57	GC25012	529	DS	15	2520S-KA	TEFC	110//115	19,20	2	
1/6	140/170	10:1	33	GC25014	529	DS	15	2520S-KA	TEFC	110//115	19,20	2	
	33/41	40:1	130	GC3320	584	DS	15	2524C-K	TEFC	110//115	19,20	3	
	67/82	20:1	75	GC3321	584	DS	15	2524C-K	TEFC	110//115	19,20	3	
	135/165	10:1	43	GC3322	584	DS	15	2524C-K	TEFC	110//115	19,20	3	
	265/320	5:1	23	GC3324	584	DS	15	2524C-K	TEFC	110//115	19,20	3	
	35/42	40:1	130	GC3326	584	DS	21	2528L-K	TEFC	110//115	19,20	4	
	71/85	20:1	75	GC3327	584	DS	21	2528L-K	TEFC	110//115	19,20	4	
	135/165	10:1	43	GC3328	584	DS	21	2528L-K	TEFC	110//115	19,20	4	
1/4	280/335	5:1	23	GC3329	584	DS	21	2528L-K	TEFC	110//115	19,20	4	
	Three Phase												
	1/4	35/42.8	40:1	170	GM3340	706	DS	24	2524M-K	TEFC	190/380//230/460	19,20	3
		70/85	20:1	112	GM3345	706	DS	24	2524M-K	TEFC	190/380//230/460	19,20	3
140/170		10:1	72	GM3347	706	DS	24	2524M-K	TEFC	190/380//230/460	19,20	3	
279/340		5:1	36	GM3349	706	DS	24	2524M-K	TEFC	190/380//230/460	19,20	3	

(a) Vertical motor below gearhead not recommended. Avoiding those positions where the high speed oil seal is immersed in oil, will provide greater security against high speed input seal wear.

(b) See notes on inside back flap and pages 5-6.

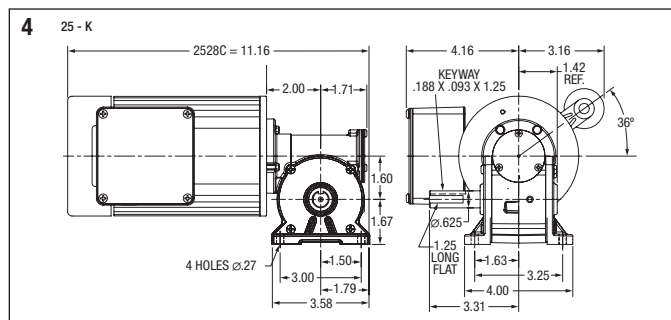
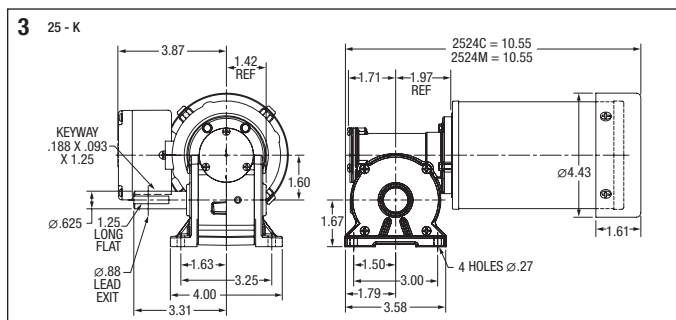
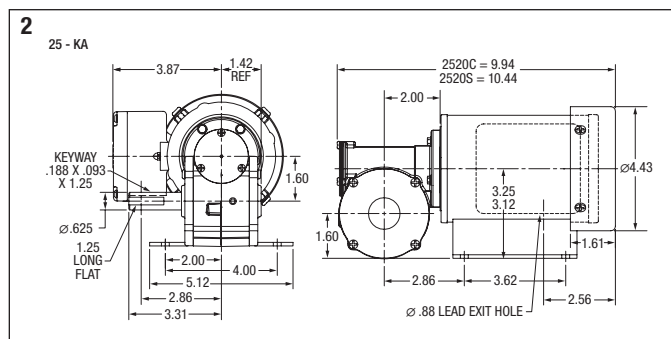
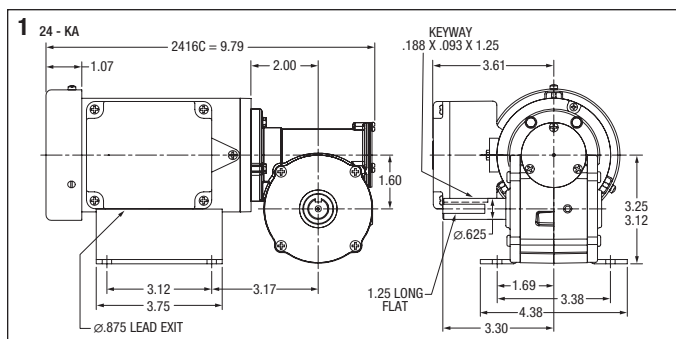



GC24322 Shown
CB Style

Applications: General purpose fixed speed including conveyors, material handling equipment and packaging machinery.

Features: Three and single-phase designs. High strength bronze gearing, hardened and ground worm for quiet operation. High performance low friction, bidirectional motor seals. Factory lubricated for life, no maintenance required. Internal oil expansion bladder allows for multiple mounting positions, without relocating a breather vent.

Input Motor Hp	Output RPM 50/60 Hz	Gear Ratio	Max. Safe Torque In. Lbs.	Catalog Number ^(a)	List Price	Mult. Sym.	Ap'x. Shpg. Wgt.	Motor Type & Gear Style	Enclosure	Voltage	Notes ^(b)	Drawing Number
Single Phase												
1/12	23/27.7	58:1	75	GC24322	449	DS	10	2420C-CB	TENV	110//115	19,20,78	1
	41/49.6	33:1	62	GC24320	449	DS	13	2420C-CB	TENV	110//115	19,20,78	1
	60/71	22.5	49	GC24318	449	DS	13	2420C-CB	TENV	110//115	19,20,78	1
	123/148	11:1	25	GC24316	449	DS	13	2420C-CB	TENV	110//115	19,20,78	1
Three Phase												
1/6	156	22.5:1	42	GM3331	615	DS	24	2512M-CA	TEFC	208-230/460	20,33	2

(a) Vertical motor below gearhead not recommended.

Avoiding those positions where the high speed oil seal is immersed in oil, will provide greater security against high speed input seal wear.

(b) See notes on inside back flap and pages 5-6.

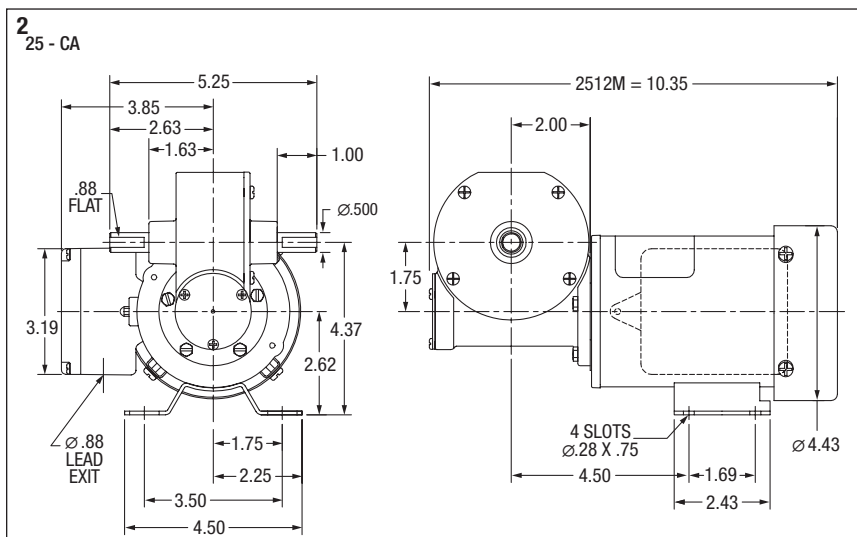
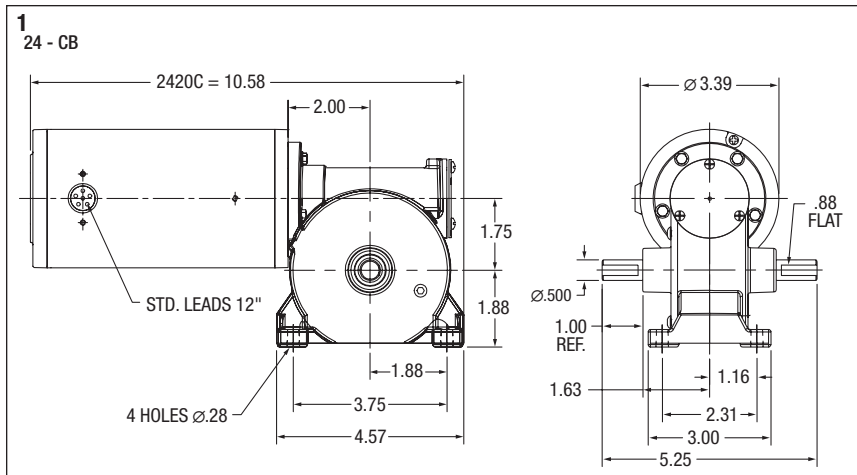



GM2503 Shown
JH Style

Applications: General purpose fixed speed including conveyors, material handling equipment and packaging machinery.

Features: Three and single-phase motor designs. High strength bronze gearing, hardened and ground worm for quiet operation. High performance low friction, bidirectional motor seals. Factory lubricated for life, no maintenance required. Internal oil expansion bladder allows for multiple mounting positions, without relocating a breather vent.

Input Motor Hp	Output RPM 50/60 Hz	Gear Ratio	Max. Safe Torque In. Lbs.	Catalog (a) Number	List Price	Mult. Sym.	Ap'x. Shpg. Wgt.	Motor Type & Gear Style	Enclosure	Voltage	Notes (b)	Drawing Number
Single Phase												
1/8	30/37	45:1	125	GC25020	535	DS	16	2524S-JK	TEFC	115	19,20	1
	43/50	33:1	100	GC25015	535	DS	16	2524S-JK	TEFC	115	19,20	1
	62/74	22.5:1	79	GC25010	535	DS	16	2524S-JK	TEFC	115	19,20	1
1/4	126/152	11:1	41	GC25005	535	DS	16	2524S-JK	TEFC	115	19,20	1
	74	22.5:1	125	GC3330	584	DS	26	3324S-JK	TEFC	115	33	2
	151	11:1	70	GC3325	584	DS	26	3324S-JK	TEFC	115	33	2
Three Phase												
1/6	38	45:1	125	GM3337	710	DS	16	2520M-JK	TEFC	208-230/460	20,33	3
	75	22.5:1	85	GM3334	710	DS	24	2520M-JK	TEFC	208-230/460	20,33	3
1/4	104	33:1	75	GM3338	710	DS	24	2520M-JK	TEFC	208-230/460	20,33	3
1/3	34	50:1	256	GM2507	723	DS	28	2528M-JH	TEFC	208-230/460	20,33	4
	42	40:1	230	GM2506	723	DS	28	2528M-JH	TEFC	208-230/460	20,33	4
	84	20:1	155	GM2503	723	DS	28	2528M-JH	TEFC	208-230/460	20,33	4
	168	10:1	90	GM2501	723	DS	28	2528M-JH	TEFC	208-230/460	20,33	4
1/2	35	50:1	295	GM3307	727	DS	35	3320M-JH	TEFC	208-230/460	33	5
	44	40:1	280	GM3306	727	DS	35	3320M-JH	TEFC	208-230/460	33	5
	88	20:1	200	GM3303	727	DS	35	3320M-JH	TEFC	208-230/460	33	5
	175	10:1	135	GM3301	727	DS	35	3320M-JH	TEFC	208-230/460	33	5

(a) Vertical motor below gearhead not recommended. Avoiding those positions where the high speed oil seal is immersed in oil, will provide greater security against high speed input seal wear. (b) See notes on inside back flap and pages 5-6.

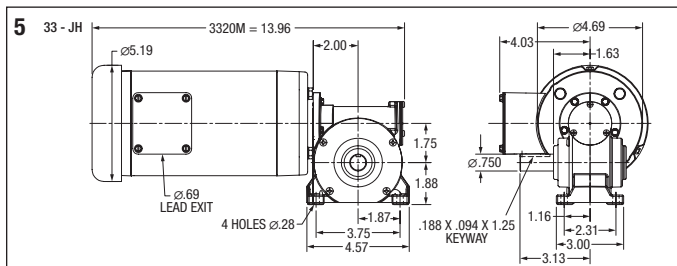
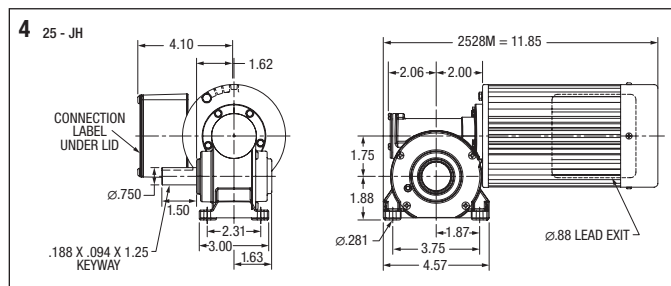
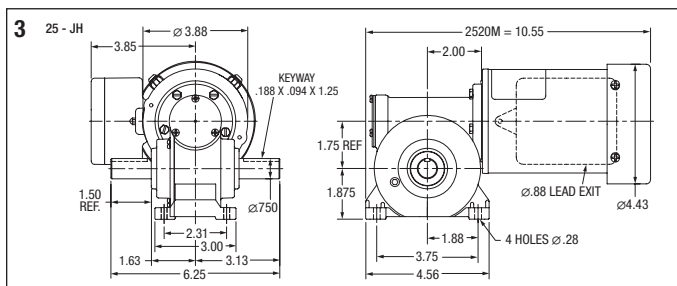
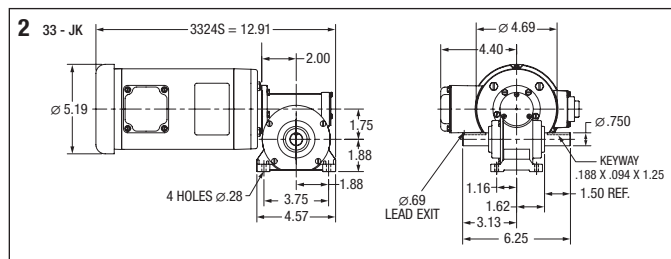
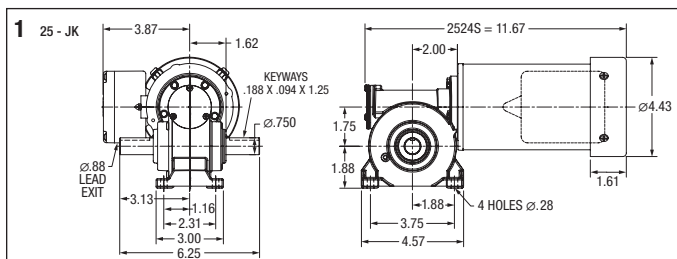

Applications: General purpose fixed speed including conveyors, material handling equipment and packaging machinery.

Features: Three and single-phase motor designs. High strength bronze gearing, hardened and ground worm for quiet operation. Permanently lubricated with synthetic Klubersynth UH1-6-460 oil, USDA food grade lubrication for H1 applications. Internal oil expansion bladder allows for multiple mounting positions, without relocating a breather vent. Double output hollow output bore is 1.00" with keyway for greater mounting flexibility. Supplied with torque arm and cover for exposed end of shaft.



GHL and GHM Shown
H Style

Input Motor Hp	Output RPM 60 Hz	Gear Ratio	Max. Safe Torque In. Lbs.	Catalog (a) Number	List Price	Mult. Sym.	Ap'x. Shpg. Wgt.	Motor Type & Gear Style	Enclosure	Voltage	Notes (b)
Single Phase											
1/2	29	60:1	600	GHL35060	937	DS	45	3421L-H	TEFC	115/230	33
	58	30:1	350	GHL35030	937	DS	45	3421L-H	TEFC	115/230	33
	88	20:1	250	GHL35020	937	DS	45	3421L-H	TEFC	115/230	33
	175	10:1	150	GHL35010	937	DS	45	3421L-H	TEFC	115/230	33
3/4	58	30:1	550	GHL37530	1,007	DS	50	3428LC-H	TEFC	115/230	33
	88	20:1	420	GHL37520	1,007	DS	50	3428LC-H	TEFC	115/230	33
	175	10:1	230	GHL37510	1,007	DS	50	3428LC-H	TEFC	115/230	33
1	58	30:1	750	GHL31030	1,150	DS	55	3524L-H	TEFC	115/230	33
	88	20:1	550	GHL31020	1,150	DS	55	3524L-H	TEFC	115/230	33
	175	10:1	300	GHL31010	1,150	DS	55	3524L-H	TEFC	115/230	33
Three Phase											
1/2	29	60:1	600	GHM35060	903	DS	40	3416M-H	TEFC	230/460	30,33
	35	50:1	609	GHM35050	903	DS	40	3416M-H	TEFC	230/460	30,33
	44	40:1	528	GHM35040	903	DS	27	3416M-H	TEFC	230/460	30,33
	58	30:1	350	GHM35030	903	DS	40	3416M-H	TEFC	230/460	30,33
	87	20:1	200	GHM35020	903	DS	40	3416M-H	TEFC	230/460	30,33
	174	10:1	135	GHM35010	903	DS	40	3416M-H	TEFC	230/460	30,33
3/4	58	30:1	550	GHM37530	929	DS	42	3420M-H	TEFC	208-230/460	33
	88	20:1	420	GHM37520	929	DS	42	3420M-H	TEFC	208-230/460	33
	175	10:1	230	GHM37510	929	DS	42	3420M-H	TEFC	208-230/460	33
1	58	30:1	750	GHM31030	954	DS	45	3426M-H	TEFC	208-230/460	33
	88	20:1	550	GHM31020	954	DS	45	3426M-H	TEFC	208-230/460	33
	175	10:1	300	GHM31010	954	DS	45	3426M-H	TEFC	208-230/460	33

(a) Vertical motor below gearhead not recommended.

Avoiding those positions where the high speed oil seal is immersed in oil, will provide greater security against high speed input seal wear.

(b) See notes on inside back flap and pages 5-6.

H Gearbox Accessories



Baldor offers optional base and shaft kits for H style gearmotors. Adding a base and shaft kit allows them to be used in applications requiring a right-angle shaft extension. The shaft can be used for either right or left hand output applications.

Catalog Number	Description	List Price	Mult. Sym.	Ap'x. Shpg. Wgt.
B19H71	Horiz Base Kit	67	A8	1
SH10HS	Output Shaft Kit	21	A8	2



GP231003 Shown
FTA Style

Applications: Conveyors, medical and laboratory equipment, printing presses, commercial ovens, machine tools and other applications requiring adjustable speed.

Features: DCPM motor provides exceptional starting torque, adjustable speed, and predictable performance over a wide range of operating conditions. Bronze sleeve bearing on output for smooth torque transmission. High strength bronze gearing and hardened and ground worm for quiet operation. Hardened and ground worm for quiet operation. Permanently lubricated with synthetic grease lubrication, can be mounted in all positions including vertical motor below gearhead.

Input Motor Hp	Output Base Speed	Gear Ratio	Max. Safe Torque In. Lbs.	Catalog Number	List Price	Mult. Sym.	Ap'x. Shpg. Wgt.	Motor Type & Gear Style	Voltage D.C. Armature	Full Load Amperage Armature	Notes ^(b)
Foot Mount											
1/50	87	20:1	7.3	GP231003	339	DS	5	2308P-FTA	90	0.34	20
1/25	140	12:1	11	GP231002	365	DS	5	2314P-FTA	90	0.54	20
1/17	312	8:1	6	GP231001	365	DS	5	2314P-FTA	90	0.62	20
1/25	344	5:1	5.1	GP232001	365	DS	5	2314P-FTA	90	0.49	20

^(b) See notes on inside back flap and pages 5-6.

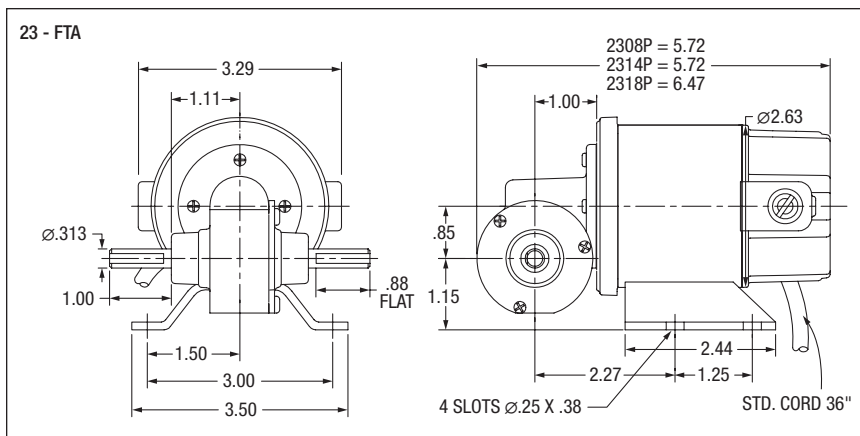



GP231005 Shown
GNA Style

Applications: Conveyors, medical and laboratory equipment, printing presses, commercial ovens, machine tools and other applications requiring adjustable speed.

Features: DCPM motor provides exceptional starting torque, adjustable speed, and predictable operating conditions. High strength bronze gearing for increased torque capacity. High performance low friction, bidirectional motor seals. Permanently lubricated for life with synthetic grease lubrication, can be mounted in all positions including vertical motor below gearhead.

Input Motor Hp	Output Base Speed	Gear Ratio	Max. Safe Torque In. Lbs.	Catalog Number	List Price	Mult. Sym.	Ap'x. Shpg. Wgt.	Motor Type & Gear Style	Voltage D.C. Armature	Full Load Amperage Armature	Notes (b)
Foot Mount											
1/97	8.2	225:1	15	GP231005	356	DS	5	2308P-GNA	90	0.19	20

(b) See notes on inside back flap and pages 5-6.

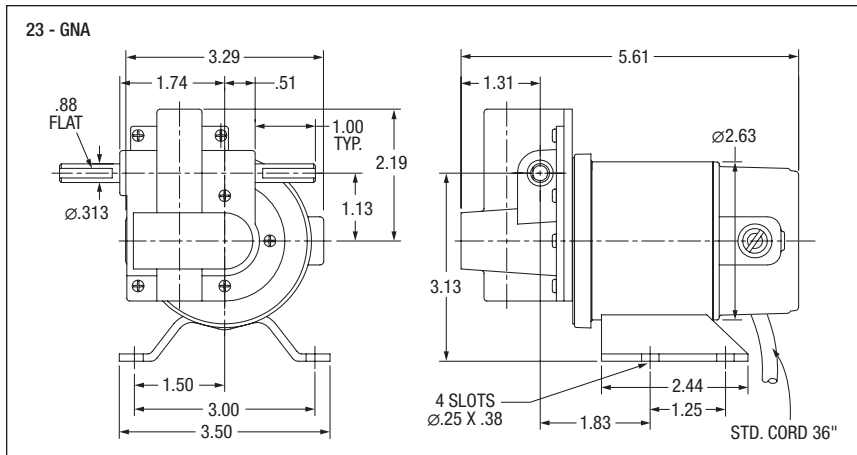



GP232002 Shown
BA Style

Applications: Conveyors, medical and laboratory equipment, printing presses, commercial ovens, machine tools and other applications requiring adjustable speed.

Features: DCPM motor provides exceptional starting torque, adjustable speed, and predictable performance over a wide range of operating conditions. Permaglidesleeve bearing on output for smooth torque transmission. High strength bronze gearing, hardened and ground worm for quiet operation. High performance low friction, bidirectional motor seals. Permanently lubricated with synthetic Mobil SHC634 oil. Internal oil expansion chamber allows for all position mounting without relocating a breather vent.

Input Motor Hp	Output Base Speed	Gear Ratio	Max. Safe Torque In. Lbs.	Catalog Number ^(a)	List Price	Mult. Sym.	Ap'x. Shpg. Wgt.	Motor Type & Gear Style	Voltage D.C. Armature	Full Load Amperage Armature	Notes ^(b)
Foot Mount											
1/22	40	40:1	30	GP232002	451	DS	7	2314P-BA	90	0.60	20
	60	30:1	33	GP233003	468	DS	8	2318P-BA	90	0.72	20
	90	20:1	27	GP233002	468	DS	7	2318P-BA	90	0.75	20
	120	15:1	22	GP233007	468	DS	7	2318P-BA	90	0.78	20
	173	10:1	17	GP233001	468	DS	7	2318P-BA	90	0.85	20
Foot Mount											
1/16	60	30:1	33	GP233023	468	DS	7	2318P-BA	180	0.42	20
1/14	86	20:1	28	GP233022	468	DS	7	2318P-BA	180	0.42	20
1/16	175	10:1	17	GP233021	468	DS	7	2318P-BA	180	0.42	20

^(a) Vertical motor below gearhead not recommended.

Avoiding those positions where the high speed oil seal is immersed in oil, will provide greater security against high speed input seal wear.

^(b) See notes on inside back flap and pages 5-6.

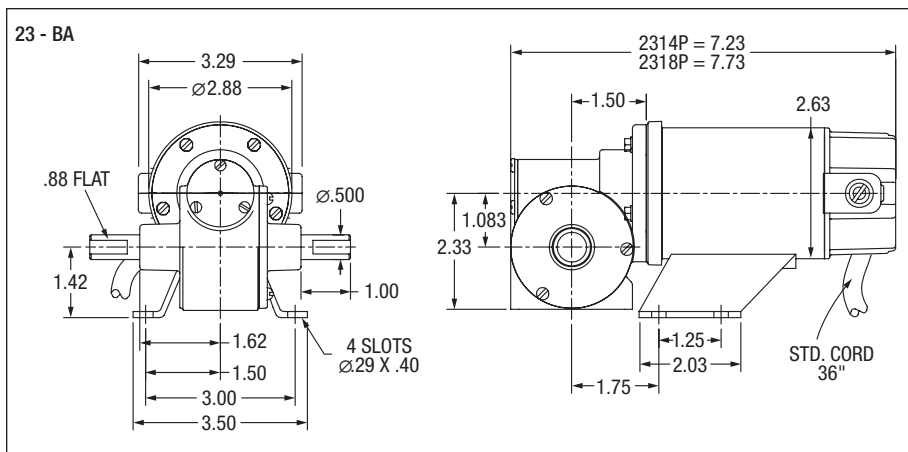



GP232004 Shown
DA Style

Applications: Conveyors, medical and laboratory equipment, printing presses, commercial ovens, machine tools and other applications requiring adjustable speed.

Features: DCPM motor provides exceptional starting torque, adjustable speed and predictable operating conditions. High strength bronze gearing for increased torque capacity. High performance low friction, bidirectional motor seals. Permanently lubricated with synthetic grease lubrication, can be mounted in all positions including vertical motor below gearhead.

Input Motor Hp	Output Base Speed	Gear Ratio	Max. Safe Torque In. Lbs.	Catalog Number ^(a)	List Price	Mult. Sym.	Ap'x. Shpg. Wgt.	Motor Type & Gear Style	Voltage D.C. Armature	Full Load Amperage Armature	Notes ^(b)
Foot Mount											
1/66	1.7	1100:1	75	GP232004	505	DS	7	2308P-DA	90	0.18	20
1/49	3.7	660:1	75	GP232005	505	DS	7	2308P-DA	90	0.34	20
1/27	8.7	310:1	66	GP232006	505	DS	7	2314P-DA	90	0.44	20
1/15	19.6	130:1	64	GP232007	527	DS	7	2314P-DA	90	0.68	20
Foot Mount											
1/83	1.9	1100:1	75	GP233020	527	DS	7	2314P-DA	180	0.11	20
1/31	4.1	660:1	75	GP233029	527	DS	7	2314P-DA	180	0.20	20
1/22	8.5	310:1	66	GP233028	527	DS	7	2314P-DA	180	0.26	20
1/20	19.7	130:1	64	GP233027	550	DS	7	2314P-DA	180	0.31	20

^(a) Vertical motor below gearhead not recommended.

Avoiding those positions where the high speed oil seal is immersed in oil, will provide greater security against high speed input seal wear.

^(b) See notes on inside back flap and pages 5-6.

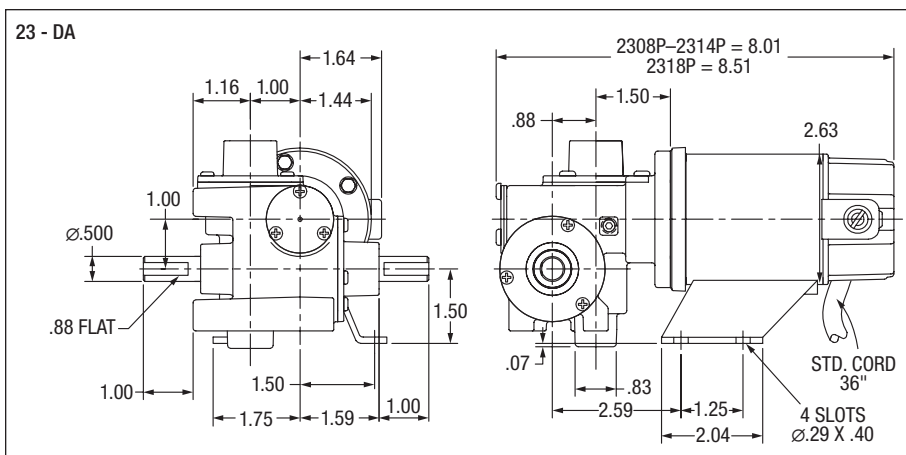



GP7409 Shown
EB Style

Applications: Conveyors, medical and laboratory equipment, printing presses, commercial ovens, machine tools and other applications requiring adjustable speed.

Features: DCPM motor provides exceptional starting torque, adjustable speed, and predictable operating conditions. High strength bronze gearing for increased torque capacity. High performance low friction, bidirectional motor seals. Permanently lubricated with synthetic grease lubrication, can be mounted in all positions including vertical motor below gearhead.

Input Motor Hp	Output Base Speed	Gear Ratio	Max. Safe Torque In. Lbs.	Catalog Number	List Price	Mult. Sym.	Ap'x. Shpg. Wgt.	Motor Type & Gear Style	Voltage D.C. Armature	Full Load Amperage Armature	Notes ^(b)
Foot Mount											
1/8	6	600:1	150	GP7304	741	DS	13	2412P-EB	90	1.00	20
1/4	20	180:1	175	GP7409	706	DS	15	2424P-EB	90	2.00	20
Foot Mount											
1/4	20	180:1	175	GP7429	729	DS	15	2424P-EB	180	1.00	20

^(b) See notes on inside back flap and pages 5-6.

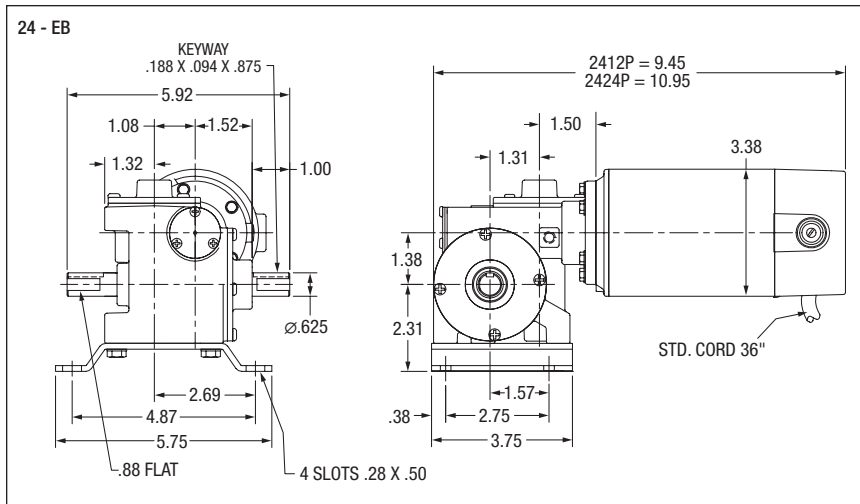



GP24280 Shown
G Style

Applications: Conveyors, medical and laboratory equipment, printing presses, commercial ovens, machine tools and other applications requiring adjustable speed.

Features: Bronze and hardened steel worm gear first stage, hardened steel helical output stage for improved overall efficiency and dependable torque transmission. Completely sealed from the environment and pre-lubricated with synthetic oil, it can be put into immediate service and does not require periodic oil changes. G gear style can be face mounted on the output shaft side, or from the bottom of the gear housing.

Input Motor Hp	Output Base Speed	Gear Ratio	Max. Safe Torque In. Lbs.	Catalog (a) Number	List Price	Mult. Sym.	Ap'x. Shpg. Wgt.	Motor Type & Gear Style	Voltage D.C. Armature	Full Load Amperage Armature	Notes (b)
Foot Mount											
1/8	6.2	280:1	400	GP24280	805	DS	12	2424P-G	90	1.80	20
	9.1	190:1	385	GP24190	805	DS	12	2424P-G	90	1.80	20
	14	120:1	280	GP24120	805	DS	12	2424P-G	90	1.80	20
	29	60:1	163	GP24060	805	DS	12	2424P-G	90	1.80	20

(a) Vertical motor below gearhead not recommended.

Avoiding those positions where the high speed oil seal is immersed in oil, will provide greater security against high speed input seal wear.

(b) See notes on inside back flap and pages 5-6.

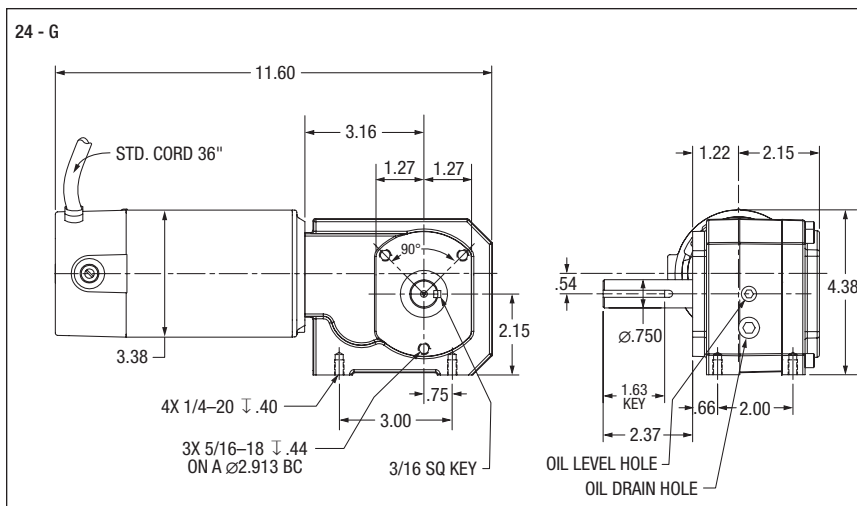



GP13530 Shown K Style

Applications: Conveyors, medical and laboratory equipment, printing presses, commercial ovens, machine tools and other applications requiring adjustable speed.

Features: DCPM motor provides exceptional starting torque, adjustable speed, and predictable operating conditions. Ball bearing on output for smooth torque transmission and increased radial load capacity. High strength bronze gearing, hardened and ground worm for quiet operation. High performance low friction, bi-directional motor seals. Permanently lubricated with synthetic Mobil SHC634 oil. Internal oil expansion chamber allows for all position mounting without relocating a breather vent.

Input Motor Hp	Output Base Speed	Gear Ratio	Max. Safe Torque In. Lbs.	Catalog (a) Number	List Price	Mult. Sym.	Ap'x. Shpg. Wgt.	Motor Type & Gear Style	Voltage D.C. Armature	Full Load Amperage Armature	Notes (b)
Foot Mount											
1/12	43	40:1	73	GP12511	575	DS	10	125-K	90	0.90	20
	86	20:1	39	GP12512	575	DS	10	125-K	90	0.90	20
	173	10:1	22	GP12514	575	DS	10	125-K	90	0.90	20
	346	5:1	10	GP12516	575	DS	10	125-K	90	0.90	20
1/6	43	40:1	135	GP13530	604	DS	10	135-K	90	1.73	20
	57	30:1	111	GP13531	604	DS	10	135-K	90	1.73	20
	88	20:1	88	GP13532	604	DS	10	135-K	90	1.73	20
	173	10:1	48	GP13533	604	DS	10	135-K	90	1.73	20
	346	5:1	24	GP13536	604	DS	10	135-K	90	1.73	20

(a) Vertical motor below gearhead not recommended.

Avoiding those positions where the high speed oil seal is immersed in oil, will provide greater security against high speed input seal wear.

(b) See notes on inside back flap and pages 5-6.

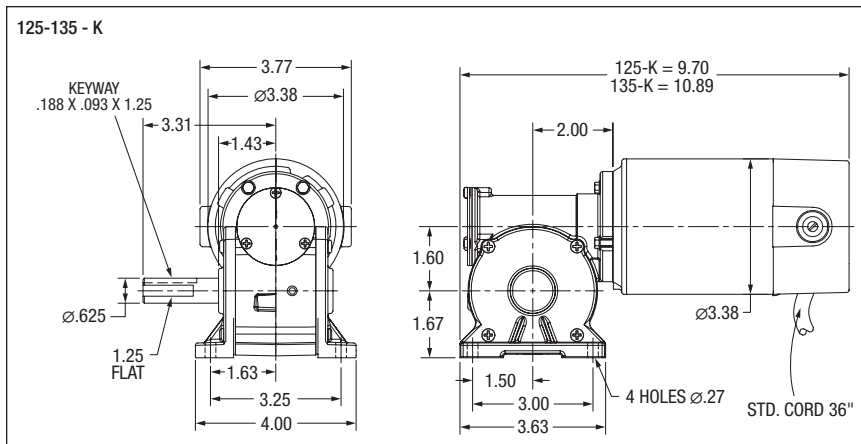



GP231004 Shown
CB Style

Applications: Conveyors, medical and laboratory equipment, printing presses, commercial ovens, machine tools and other applications requiring adjustable speed.

Features: DCPM motor provides exceptional starting torque, adjustable speed, and predictable performance over a wide range of operating conditions. Permaglide sleeve bearing on output for smooth torque transmission. High strength bronze gearing, hardened and ground worm for quiet operation. High performance low friction, bidirectional motor seals. Permanently lubricated with synthetic Mobil SHC634 oil. Internal oil expansion chamber allows for all position mounting without relocating a breather vent.

Input Motor Hp	Output Base Speed	Gear Ratio	Max. Safe Torque In. Lbs.	Catalog (a) Number	List Price	Mult. Sym.	Ap'x. Shpg. Wgt.	Motor Type & Gear Style	Voltage D.C. Armature	Full Load Amperage Armature	Notes (b)
Foot Mount											
1/25	22	72:1	45	GP231004	451	DS	8	2314P-CB	90	0.53	20
	30	58:1	38	GP232003	451	DS	8	2314P-CB	90	0.53	20
1/16	38	45:1	57	GP233006	468	DS	8	2318P-CB	90	0.80	20
	52	33:1	48	GP233005	468	DS	8	2318P-CB	90	0.75	20
	76	22.5:1	33	GP233004	468	DS	8	2318P-CB	90	0.85	20
Foot Mount											
1/16	41	45:1	57	GP233026	468	DS	8	2318P-CB	180	0.42	20
	53	33:1	48	GP233025	468	DS	8	2318P-CB	180	0.40	20
1/14	76	22.5:1	76	GP233024	468	DS	8	2318P-CB	180	0.42	20

(a) Vertical motor below gearhead not recommended.

Avoiding those positions where the high speed oil seal is immersed in oil, will provide greater security against high speed input seal wear.

(b) See notes on inside back flap and pages 5-6.

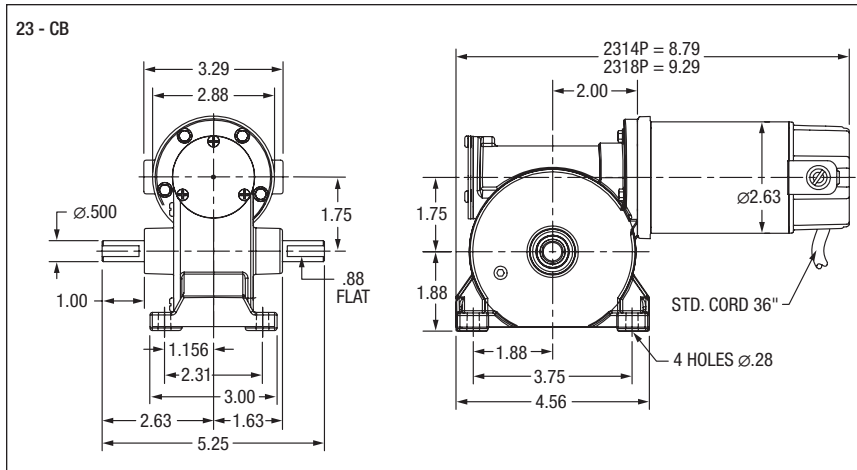



GP7404 Shown
JK Style

Applications: Conveyors, medical and laboratory equipment, printing presses, commercial ovens, machine tools and other applications requiring adjustable speed.

Features: DCPM motor provides exceptional starting torque, adjustable speed, and predictable operating conditions. Ball bearing on output for smooth torque transmission and increased radial load capacity High strength bronze gearing, hardened and ground worm for quiet operation. High performance low friction, bidirectional motor seals. Factory lubricated with synthetic oil. Internal oil expansion chamber allows for all position mounting without relocating a breather vent.

Input Motor Hp	Output Base Speed	Gear Ratio	Max. Safe Torque In. Lbs.	Catalog Number (a)	List Price	Mult. Sym.	Ap'x. Shpg. Wgt.	Motor Type & Gear Style	Voltage D.C. Armature	Full Load Amperage Armature	Notes (b)	Drawing Number
Foot Mount												
1/8	30	58:1	120	GP7404	641	DS	14	2424P-JK	90	1.30	20	1
	38	45:1	100	GP7403	641	DS	14	2424P-JK	90	1.30	20	1
	52	33:1	75	GP7402	641	DS	14	2424P-JK	90	1.30	20	1
	75	22.5:1	60	GP7401	641	DS	14	2424P-JK	90	1.30	20	1
1/5	173	11:1	32	GP7400	641	DS	14	2424P-JK	90	1.30	20	1
	50	45:1	120	GP7408	641	DS	14	2428P-JK	90	2.20	20	1
1/4	68	33:1	112	GP7405	641	DS	14	2428P-JK	90	2.40	20	1
	76	45:1	100	GP7407	641	DS	14	2428P-JK	90	2.60	20	1
	104	33:1	75	GP7406	641	DS	14	2428P-JK	90	2.60	20	1
	314	8:1	32	GP7413	641	DS	14	2428P-JK	90	2.60	20	1
Foot Mount												
1/8	30	58:1	120	GP7424	641	DS	14	2420P-JK	180	0.64	20	1
	38	45:1	100	GP7423	641	DS	14	2420P-JK	180	0.64	20	1
	52	33:1	75	GP7422	641	DS	14	2420P-JK	180	0.64	20	1
	78	22.5:1	60	GP7421	641	DS	14	2420P-JK	180	0.64	20	1
1/5	173	11:1	32	GP7420	641	DS	14	2420P-JK	180	0.65	20	1
	50	45:1	120	GP7428	641	DS	14	2428P-JK	180	1.10	20	1
1/4	68	45:1	135	GP7425	641	DS	14	2428P-JK	180	1.30	20	1
	76	45:1	100	GP7427	641	DS	14	2428P-JK	180	1.30	20	1
	104	33:1	75	GP7426	641	DS	14	2428P-JK	180	1.30	20	1
	314	11:1	32	GP7433	641	DS	14	2428P-JK	180	1.30	20	1
Foot Mount												
1/3	48	50:1	150	GP2507	787	DS	25	2532P-JH	90	3.36	20	2
	62	40:1	137	GP2506	787	DS	25	2532P-JH	90	3.36	20	2
	123	20:1	95	GP2503	787	DS	25	2532P-JH	90	3.36	20	2
	245	10:1	65	GP2501	787	DS	25	2532P-JH	90	3.36	20	2
1/2	50	50:1	234	GP3307	914	DS	35	3327P-JH	90	5.00	20	3
	63	40:1	215	GP3306	914	DS	35	3327P-JH	90	5.00	20	3
	125	20:1	145	GP3303	914	DS	35	3327P-JH	90	5.00	20	3
	250	10:1	100	GP3301	914	DS	35	3327P-JH	90	5.00	20	3

(a) Vertical motor below gearhead not recommended. Avoiding those positions where the high speed oil seal is immersed in oil, will provide greater security against high speed input seal wear.

(b) See notes on inside back flap and pages 5-6.

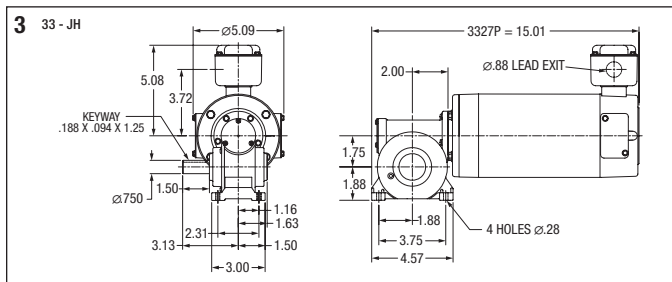
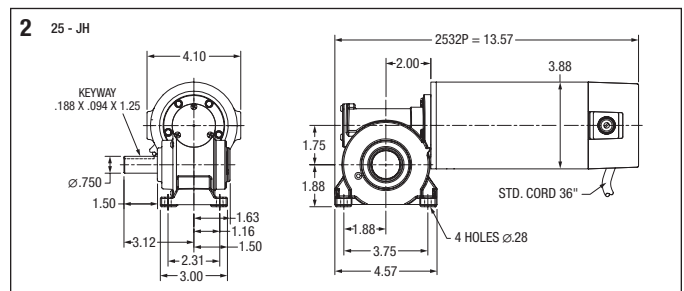
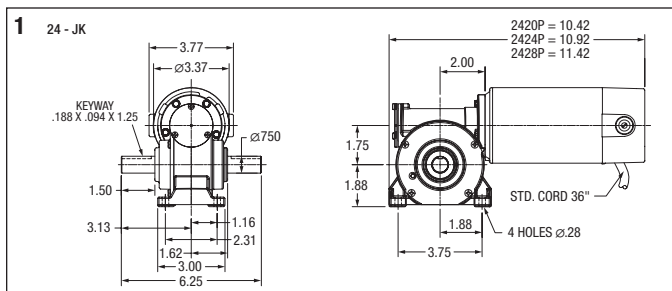



GPF13517 Shown
JAF Style

Applications: Conveyors, medical and laboratory equipment, printing presses, commercial ovens, machine tools and other applications requiring adjustable speed.

Features: DCPM motor provides exceptional starting torque, adjustable speed, and predictable operating conditions. Ball bearing on output for smooth torque transmission and increased radial load capacity. High strength bronze gearing, hardened and ground worm for quiet operation. High performance low friction, bi-directional motor seals. Factory lubricated with synthetic oil. Internal oil expansion chamber allows for all position mounting without relocating a breather vent.

Input Motor Hp	Output Base Speed	Gear Ratio	Max. Safe Torque In. Lbs.	Catalog (a) Number	List Price	Mult. Sym.	Ap'x. Shpg. Wgt.	Motor Type & Gear Style	Voltage D.C. Armature	Full Load Amperage Armature	Notes (b)
Flange Mount											
1/4	312	8:1	38.0	GPF13514	666	DS	15	2428P-JAF	90	2.5	20
	167	15:1	69.0	GPF13515	666	DS	15	2428P-JAF	90	2.5	20
	111	22.5:1	96.0	GPF13516	666	DS	15	2428P-JAF	90	2.6	20
	76	33:1	110.0	GPF13517	666	DS	15	2428P-JAF	90	2.2	20
Flange Mount											
1/5	167	15:1	55.0	GPF13530	666	DS	15	135-JAF	180	1.0	20
	76	33:1	88.0	GPF13532	666	DS	15	135-JAF	180	1.0	20

(a) Vertical motor below gearhead not recommended.

Avoiding those positions where the high speed oil seal is immersed in oil, will provide greater security against high speed input seal wear.

(b) See notes on inside back flap and pages 5-6.

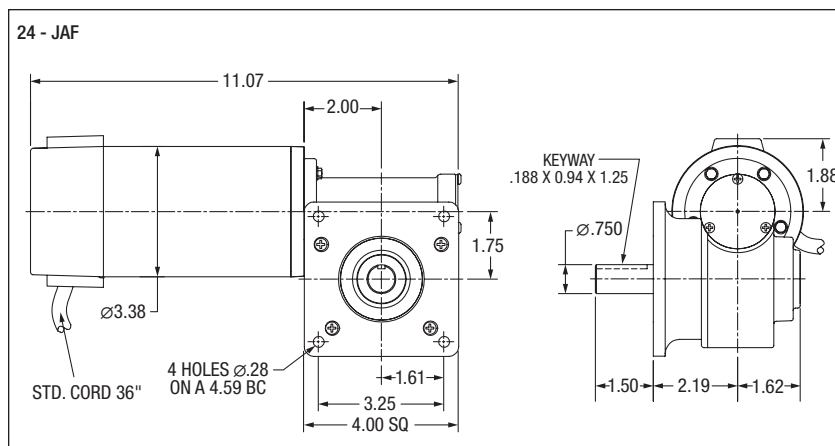



GCP24114 Shown
PSSH Style

Applications: Conveyors, packaging machines, machine tools and laboratory equipment requiring constant speed.

Features: Induction hardened helical and spur gears for extra strength. Ball and needle-bearing construction for improved torque capacity. Factory lubricated for life, no maintenance required. Industry standard dimensions. See optional mounting bracket on pages 355 and 391.

Input Motor Hp	Output RPM 50/60 Hz.	Gear Ratio	Stages	Max. Safe Torque In. Lbs.	Catalog (a) Number	List Price	Mult. Sym.	Ap'x. Shpg. Wgt.	Motor Type & Gear Style	Enclosure	Voltage	Notes (b)	Drawing Number
Single Phase													
1/40	7.6/9.4	180:1	4	120	GCP24114	464	DS	10	2412C-PSSH	TENV	115	19,20,78	2
1/25	15.3/18	90:1	4	120	GCP24122	468	DS	10	2416C-PSSH	TENV	115	19,20,78	2
	23/27.3	60:1	3	80.7	GCP24124	468	DS	10	2416C-PSSH	TENV	115	19,20,78	1
1/12	45/54.8	30:1	3	83.7	GCP24134	449	DS	10	2424C-PSSH	TENV	115	19,20,78	1
	68/82.5	20:1	2	55.8	GCP24136	449	DS	10	2424C-PSSH	TENV	115	19,20,78	1
	90/109	15:1	2	42.8	GCP24138	449	DS	10	2424C-PSSH	TENV	115	19,20,78	1
	136/163	10:1	2	28.5	GCP24140	449	DS	10	2424C-PSSH	TENV	115	19,20,78	1
	272/326	5:1	2	14.3	GCP24142	449	DS	10	2424C-PSSH	TENV	115	19,20,78	1

(a) Vertical motor below gearhead not recommended.

Avoiding those positions where the high speed oil seal is immersed in oil, will provide greater security against high speed input seal wear.

(b) See notes on inside back flap and pages 5-6.

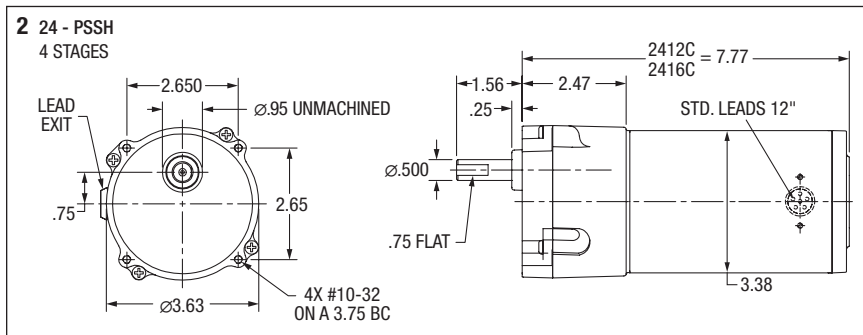
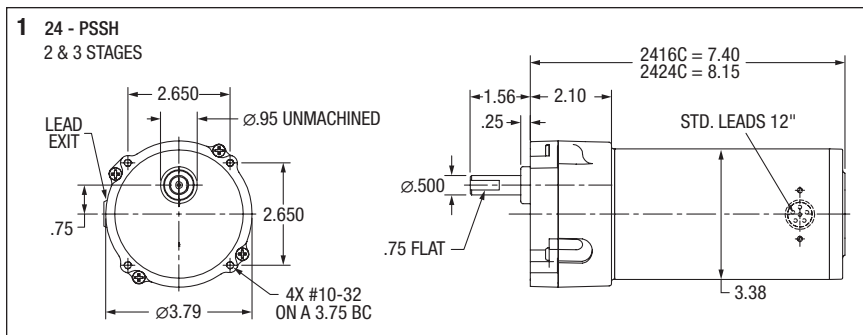



GCP24232 Shown
PSM Style

Applications: Conveyors, packaging machines, machine tools and laboratory equipment requiring constant speed.

Features: Induction hardened helical and spur gears for extra strength. Ball and needle-bearing construction for improved torque capacity. Factory lubricated for life, no maintenance required. Industry standard dimensions. Optional bases for foot or 3-point face mounting, see below.

Input Motor Hp	Output RPM 50/60 Hz.	Gear Ratio	Stages	Max. Safe Torque In. Lbs.	Catalog (a) Number	List Price	Mult. Sym.	Ap'x. Shpg. Wgt.	Motor Type & Gear Style	Enclosure	Voltage	Notes (b)	Drawing Number
Single Phase													
1/15	15/18	90:1	4	237	GCP24232	539	DS	14	2424C-PSM	TENV	115	19,20,78	1
1/12	23/27	60:1	3	167	GCP24234	510	DS	14	2424C-PSM	TENV	115	19,20,78	1
1/9	43/36	40:1	3	149	GCP25052	514	DS	14	2524S-PSM	TEFC	115	19,20	2
	47/57	30:1	3	112	GCP25054	514	DS	14	2524S-PSM	TEFC	115	19,20	2
	84/70	20:1	3	74	GCP25056	489	DS	14	2524S-PSM	TEFC	115	19,20	2
	92/111	15:1	2	57	GCP25058	489	DS	14	2524S-PSM	TEFC	115	19,20	2
	138/166	10:1	2	38	GCP25060	489	DS	14	2524S-PSM	TEFC	115	19,20	2
	275/330	5:1	2	19	GCP25062	489	DS	14	2524S-PSM	TEFC	115	19,20	2

(a) Vertical motor below gearhead not recommended.

Avoiding those positions where the high speed oil seal is immersed in oil, will provide greater security against high speed input seal wear.

(b) See notes on inside back flap and pages 5-6.

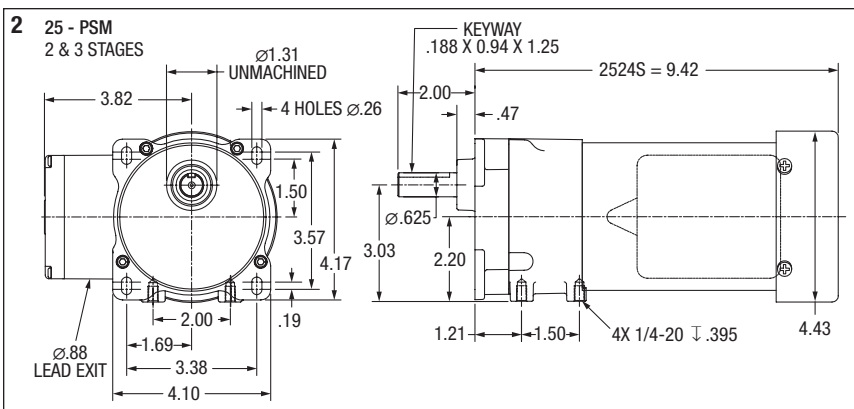
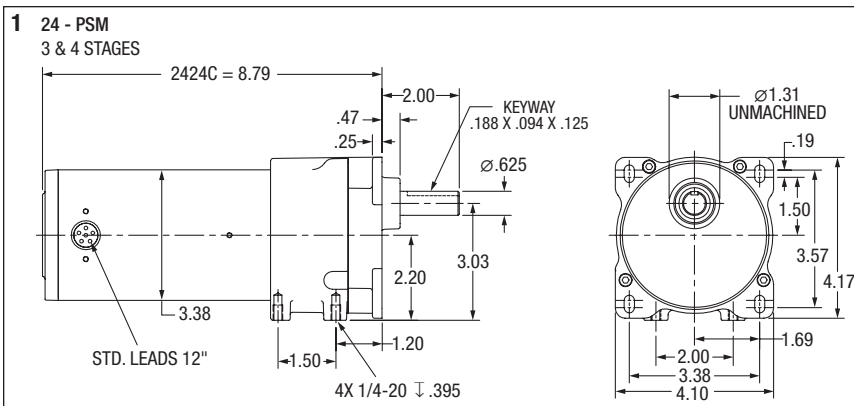

PSM Mounting Adapters



B92 is formed steel mounting base that bolts to machined surface on bottom of PSM gear box casting. Provides secure foot mounting of gearmotor and drop-in interchangeability with other major manufacturers.

B93 is a three point face mounting adapter. Provides interchangeability with other manufacturers.

Catalog Number	Description	List Price	Mult. Sym.	Ap'x. Shpg. Wgt.
B92	Foot Mount	40	A8	1
B93	3 Point Face Mount	51	A8	1



PSL Style

Applications: Conveyors, packaging machines, machine tools and laboratory equipment requiring constant speed.

Features: Three and single-phase. Induction hardened helical gears for added strength. Ball and needle-bearing construction for improved torque capacity. Factory lubricated for life, no maintenance required. Industry standard dimensions. An optional bolt-on base is available for foot mounting on pages 355 and 391.

Input Motor Hp	Output RPM 50/60 Hz.	Gear Ratio	Stages	Max. Safe Torque In. Lbs.	Catalog (a) Number	List Price	Mult. Sym.	Ap'x. Shpg. Wgt.	Motor Type & Gear Style	Enclosure	Voltage	Notes (b)	Drawing Number
Single Phase													
1/25	4.5/5.5	300:1	4	325	GCP24002	692	DS	15	2416C-PSL	TENV	110//115	19,20,78	1
	7.6/9.1	180:1	4	235	GCP24004	692	DS	15	2416C-PSL	TENV	110//115	19,20,78	1
1/12	11/13.7	120:1	4	330	GCP24020	747	DS	15	2424C-PSL	TENV	110//115	19,20,78	1
	15/18.2	90:1	4	250	GCP24022	669	DS	15	2424C-PSL	TENV	110//115	19,20,78	1
1/8	23/28	60:1	3	270	GCP25002	726	DS	18	2524S-PSL	TEFC	110//115	19,20	2
	45/55	30:1	3	135	GCP25004	726	DS	18	2524S-PSL	TEFC	110//115	19,20	2
	71/85	20:1	2	92	GCP25006	700	DS	18	2524S-PSL	TEFC	110//115	19,20	3
	141/170	10:1	2	46	GCP25008	700	DS	18	2524S-PSL	TEFC	110//115	19,20	3
	283/340	5:1	2	23	GCP25010	700	DS	18	2524S-PSL	TEFC	110//115	19,20	3
1/6	58	30:1	3	164	GCP3305	734	DS	24	3316C-PSL	TENV	115	33	4
	86	20:1	2	112	GCP3310	707	DS	24	3316C-PSL	TENV	115	33	4
	173	10:1	2	56	GCP3315	707	DS	24	3316C-PSL	TENV	115	33	4
Capacitor Start - Single Phase													
1/4	29	60:1	3	483	GLP3310	793	DS	25	3320L-PSLH	TEFC	115/208-230	33	5
1/3	35	50:1	3	438	GLP3328	825	DS	25	3324L-PSLH	TEFC	115/208-230	20,33	5
	57.5	30:1	3	320	GLP3330	825	DS	25	3324L-PSLH	TEFC	115/208-230	20,33	5
	86.3	20:1	2	218	GLP3332	776	DS	25	3324L-PSLH	TEFC	115/208-230	20,33	5
	172.5	10:1	2	109	GLP3336	776	DS	25	3324L-PSLH	TEFC	115/208-230	20,33	5
	345	5:1	2	55	GLP3338	776	DS	25	3324L-PSLH	TEFC	115/208-230	20,33	5
1/2	58	30:1	3	484	GLP3342	871	DS	25	3328L-PSLH	TEFC	115/208-230	20,33	5
	88	20:1	2	326	GLP3344	821	DS	25	3328L-PSLH	TEFC	115/208-230	20,33	5
	117	15:1	2	245	GLP3346	821	DS	25	3328L-PSLH	TEFC	115/208-230	20,33	5
	175	10:1	2	164	GLP3348	821	DS	25	3328L-PSLH	TEFC	115/208-230	20,33	5
Three Phase													
1/3	57	30:1	3	320	GMP3330	817	DS	27	3320M-PSLH	TEFC	208-230/460	33	6
	86	20:1	2	218	GMP3332	768	DS	27	3320M-PSLH	TEFC	208-230/460	33	6
	173	10:1	2	109	GMP3336	768	DS	27	3320M-PSLH	TEFC	208-230/460	33	6
	345	5:1	2	55	GMP3338	768	DS	27	3320M-PSLH	TEFC	208-230/460	33	6
1/2	43	40:1	3	627	GMP3340	863	DS	27	3320M-PSLH	TEFC	208-230/460	33	6
	58	30:1	3	484	GMP3342	863	DS	27	3320M-PSLH	TEFC	208-230/460	33	6
	86	20:1	2	326	GMP3344	814	DS	27	3320M-PSLH	TEFC	208-230/460	33	6
	173	10:1	2	164	GMP3348	814	DS	27	3320M-PSLH	TEFC	208-230/460	33	6

(a) Vertical motor below gearhead not recommended.

Avoiding those positions where the high speed oil seal is immersed in oil, will provide greater security against high speed input seal wear.

(b) See notes on inside back flap and pages 5-6.

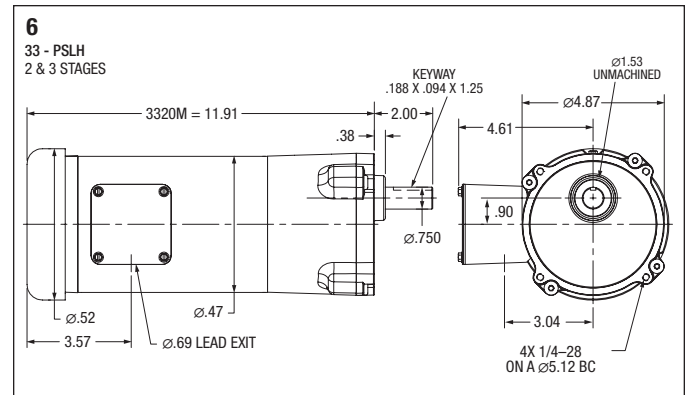
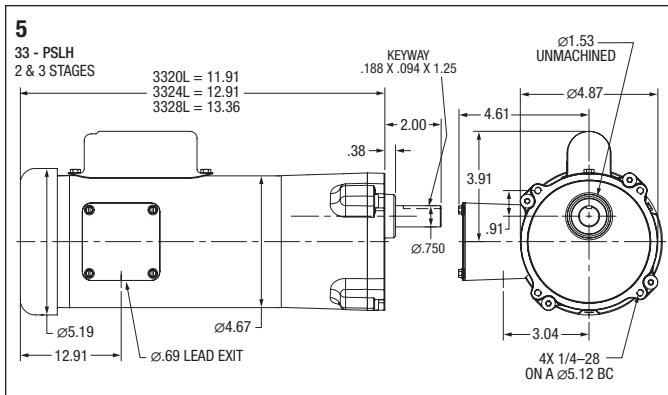
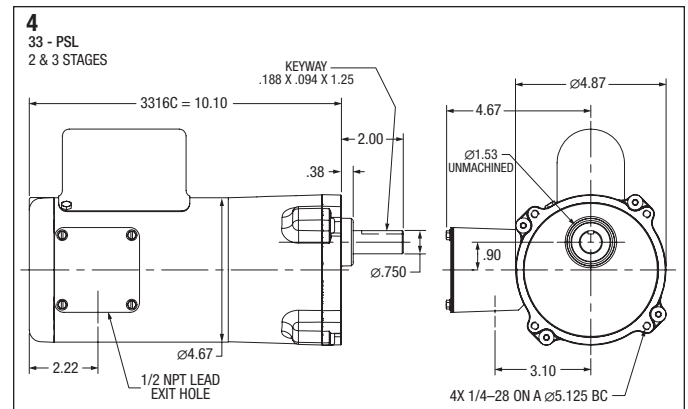
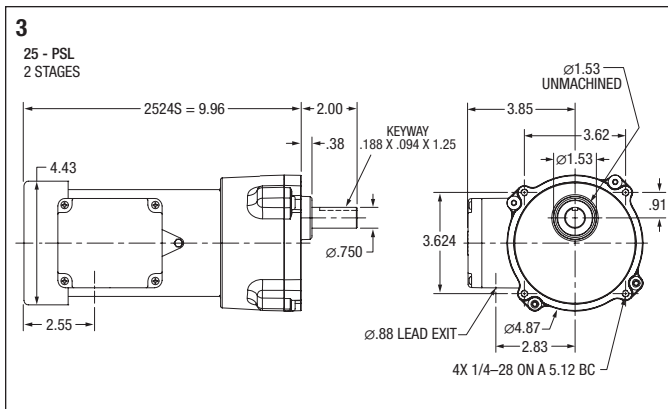
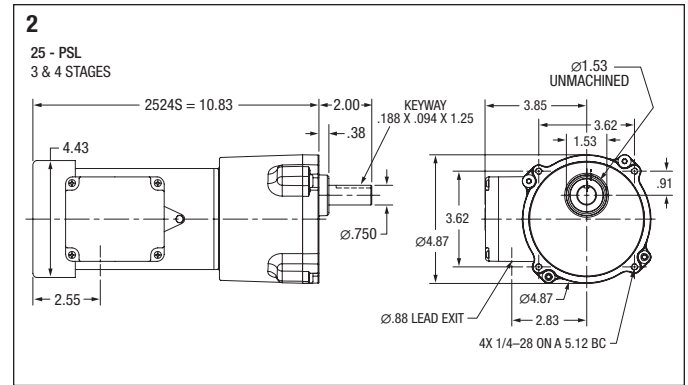
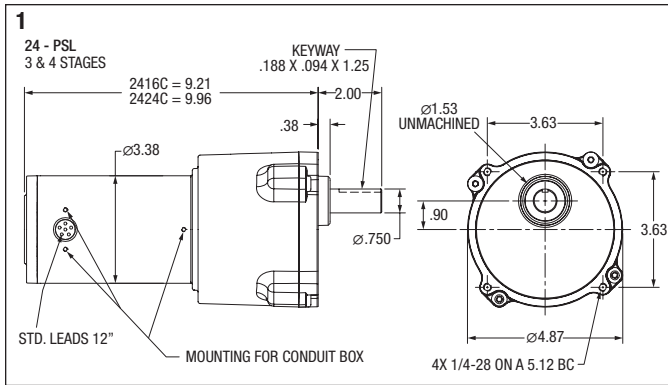

"L" Type Mounting Brackets



Applications: Mounting bracket for PSSH and PSL gear motors. Securely mounts to gear face in 90 degree locations for floor, wall or ceiling mount. Catalog LB74 is not recommended for PSL/PSLH units weighing over 20 lbs. For units weighing more than 20 lbs. use LB75.

Catalog Number	List Price	Mult. Sym.	Ap'x. Shpg. Wgt
LB73	40	A8	2
LB73GR	40	A8	2
LB74	57	A8	2
LB75	79	A8	7

NOTE: Painted Baldor gray. LB73 & LB73GR for PSSH style gearmotors, LB74 & LB75 for PSL/PSLH style gearmotors.



GPP233141 Shown
PSM Style

Applications: Conveyors, medical and laboratory equipment, printing presses, commercial ovens, machine tools and many other applications requiring adjustable speed.

Features: Induction hardened helical and spur gears for extra strength. Ball and needle-bearing construction for improved torque capacity. Factory lubricated for life, no maintenance required. PSM is face or foot mounted with industry standard dimensions. Optional bases are available for foot or 3-point face mounting, see pages 353 and 391.

Input Motor Hp	Output Base Speed	Gear Ratio	Stages	Max. Safe Torque In. Lbs.	Catalog (a) Number	List Price	Mult. Sym.	Ap'x. Shpg. Wgt.	Motor Type & Gear Style	Voltage D.C. Armature	Full Load Amperage Armature	Notes (b)	Drawing Number
1/16	15.4	120:1	4	197	GPP233141	577	DS	10	2318P-PSM	90	0.66	20	1
1/15	18.6	90:1	4	180	GPP233140	577	DS	10	2318P-PSM	90	0.77	20	1
1/8	42	60:1		165	GPP12547	578	DS	12	2416P-PSM	90	1.35	20	2
	63	40:1		116	GPP12545	578	DS	12	2416P-PSM	90	1.35	20	2
	83	30:1		90	GPP12544	578	DS	12	2416P-PSM	90	1.35	20	2
	125	20:1		58	GPP12543	553	DS	12	2416P-PSM	90	1.35	20	2
	167	15:1		45	GPP12542	553	DS	12	2416P-PSM	90	1.35	20	2
	250	10:1		30	GPP12541	553	DS	12	2416P-PSM	90	1.35	20	2
1/8	500	5:1		15	GPP12540	553	DS	12	2416P-PSM	90	1.35	20	2
	42	60:1		174	GPP12567	558	DS	11	2416P-PSM	180	0.65	20	2
	83	30:1		87	GPP12564	558	DS	11	2416P-PSM	180	0.65	20	2
	250	10:1		30	GPP12561	553	DS	11	2416P-PSM	180	0.65	20	2
	500	5:1		14.8	GPP12560	553	DS	11	2416P-PSM	180	0.65	20	2

(a) Vertical motor below gearhead not recommended.

Avoiding those positions where the high speed oil seal is immersed in oil, will provide greater security against high speed input seal wear.

(b) See notes on inside back flap and pages 5-6.

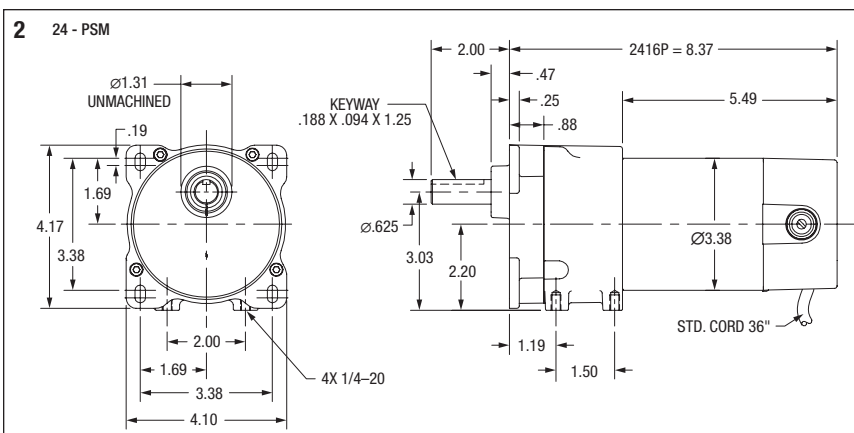
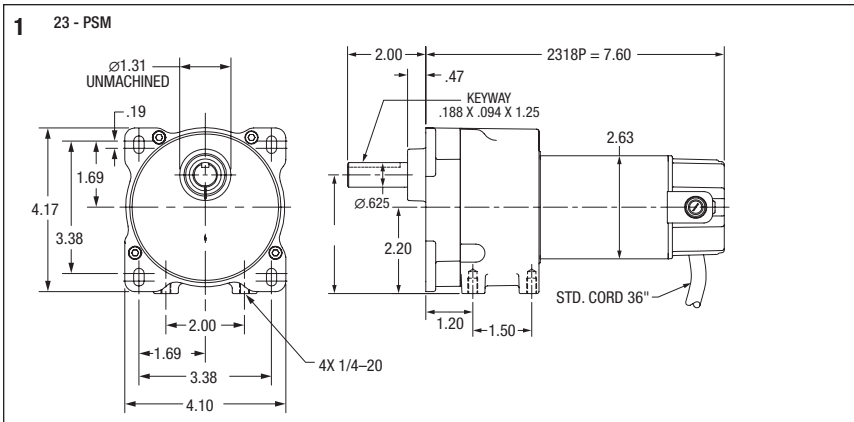



GPP7459 Shown
PSL Style

Applications: Conveyors, medical and laboratory equipment, printing presses, commercial ovens, machine tools and many other applications requiring adjustable speed.

Features: Induction hardened helical gears for added strength. Ball and needle-bearing construction for improved torque capacity. Factory lubricated for life, no maintenance required. PSL is face mounted with industry standard dimensions. An optional bolt on base is available for foot mounting. See pages 355 and 391.

Input Motor Hp	Output Base Speed	Gear Ratio	Stages	Max. Safe Torque In. Lbs.	Catalog Number ^(a)	List Price	Mult. Sym.	Ap'x. Shpg. Wgt.	Motor Type & Gear Style	Voltage D.C. Armature	Full Load Amperage Armature	Notes ^(b)	Drawing Number
1/8	8.3	300:1	4	330	GPP7459	729	DS	17	2416P-PSL	90	0.76	20	1
1/8	10.4	240:1	4	330	GPP7462	729	DS	17	2416P-PSL	90	0.71	20	1
1/4	14	180:1	4	365	GPP7458	729	DS	17	2424P-PSL	90	1.20	20	1
1/4	21	120:1	4	365	GPP7457	729	DS	17	2424P-PSL	90	1.70	20	1
1/4	28	90:1	4	390	GPP7461	729	DS	17	2424P-PSL	90	2.25	20	1
1/4	42	60:1	3	280	GPP7456	700	DS	17	2424P-PSL	90	2.50	20	1
1/4	50	50:1	3	250	GPP7460	700	DS	17	2424P-PSL	90	2.50	20	1
1/4	62	40:1	3	200	GPP7455	700	DS	17	2424P-PSL	90	2.50	20	1
1/4	83	30:1	3	150	GPP7454	700	DS	17	2424P-PSL	90	2.50	20	1
1/4	125	20:1	2	100	GPP7453	700	DS	17	2424P-PSL	90	2.50	20	2
1/4	165	15:1	2	75	GPP7452	643	DS	15	2424P-PSL	90	2.50	20	2
1/4	250	10:1	2	50	GPP7451	643	DS	17	2424P-PSL	90	2.50	20	2
1/4	500	5:1	2	25	GPP7450	643	DS	17	2424P-PSL	90	2.50	20	2
1/3	58	30:1	3	320	GPP2530	956	DS	24	2532P-PSLH	90	3.20	20	3
1/3	113	15:1	2	164	GPP2534	910	DS	24	2532P-PSLH	90	3.20	20	3
1/3	345	5:1	2	55	GPP2538	910	DS	24	2532P-PSLH	90	3.20	20	3
1/2	83	30:1	3	337	GPP3340	1,074	DS	35	3327P-PSLH	90	5.00	20	4
1/2	167	15:1	2	171	GPP3344	1,074	DS	31	3327P-PSLH	90	5.00	20	4
1/2	500	5:1	2	57	GPP3348	1,027	DS	35	3327P-PSLH	90	5.00	20	4
1/8	8.3	300:1	4	330	GPP7479	729	DS	17	2424P-PSL	180	0.38	20	1
1/4	14	180:1	4	365	GPP7478	729	DS	17	2424P-PSL	180	0.60	20	1
1/4	21	120:1	4	365	GPP7477	729	DS	17	2424P-PSL	180	0.85	20	1
1/4	42	60:1	3	280	GPP7476	700	DS	17	2424P-PSL	180	1.25	20	1
1/4	62	40:1	3	200	GPP7475	700	DS	17	2424P-PSL	180	1.25	20	1
1/4	83	30:1	3	155	GPP7474	700	DS	17	2424P-PSL	180	1.25	20	1
1/4	125	20:1	2	100	GPP7473	700	DS	17	2424P-PSL	180	1.25	20	2
1/4	165	15:1	2	75	GPP7472	643	DS	17	2424P-PSL	180	1.25	20	2
1/4	250	10:1	2	50	GPP7471	643	DS	17	2424P-PSL	180	1.25	20	2
1/4	500	5:1	2	25	GPP7470	643	DS	17	2424P-PSL	180	1.25	20	2
1/3	58	30:1	3	320	GPP3370	1,074	DS	35	3327P-PSLH	180	1.50	20	4
1/3	115	15:1	2	164	GPP3374	1,027	DS	35	3327P-PSLH	180	1.50	20	4
1/3	345	5:1	2	55	GPP3378	1,027	DS	35	3327P-PSLH	180	1.60	20	4
1/2	83	30:1	3	337	GPP3380	1,074	DS	35	3327P-PSLH	180	2.50	20	4
1/2	167	15:1	2	171	GPP3384	1,027	DS	35	3327P-PSLH	180	2.50	20	4
1/2	500	5:1	2	57	GPP3388	1,027	DS	35	3327P-PSLH	180	2.50	20	4

^(a) Vertical motor below gearhead not recommended.

Avoiding those positions where the high speed oil seal is immersed in oil, will provide greater security against high speed input seal wear.

^(b) See notes on inside back flap and pages 5-6.

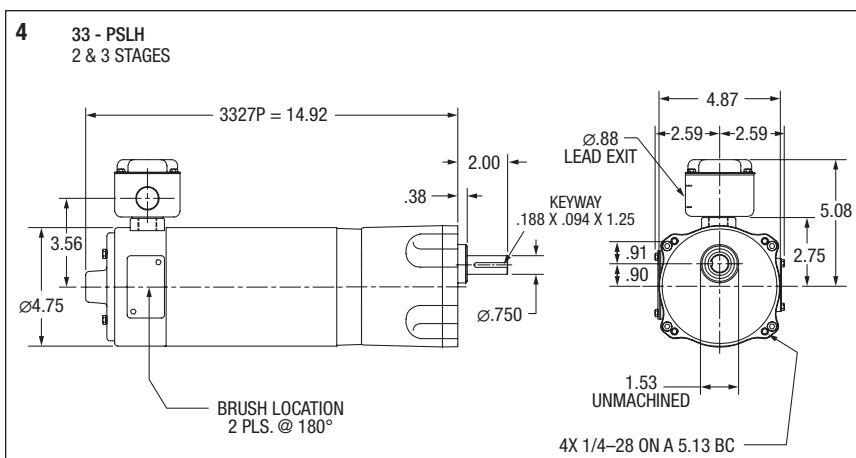
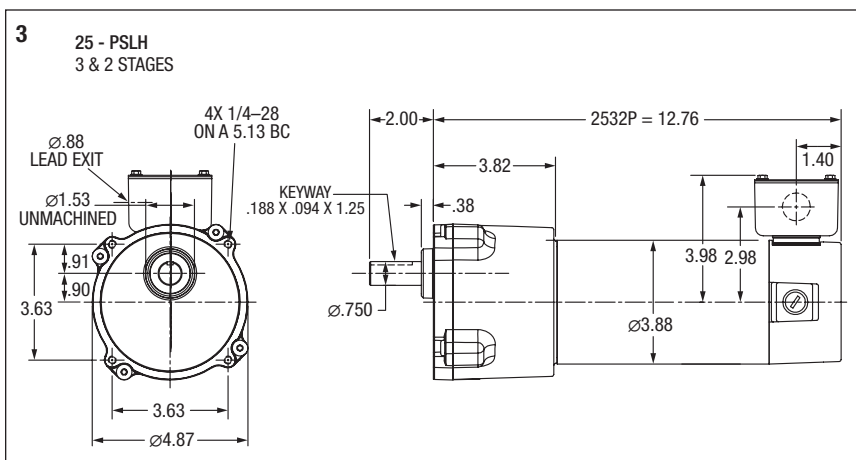
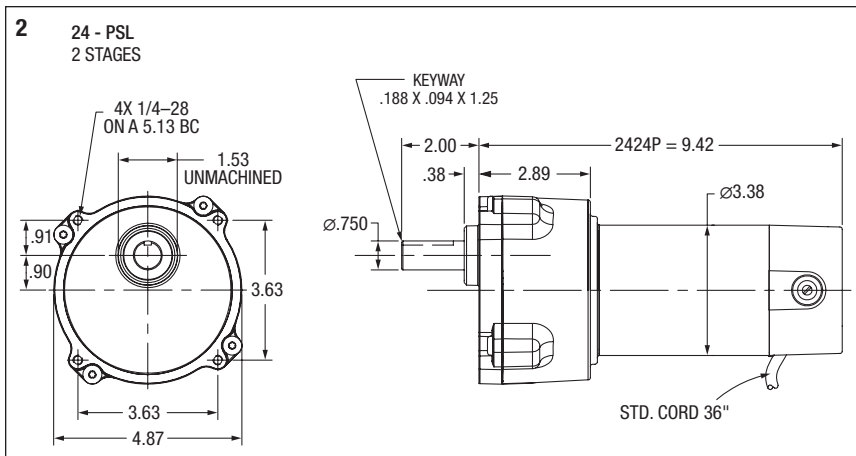
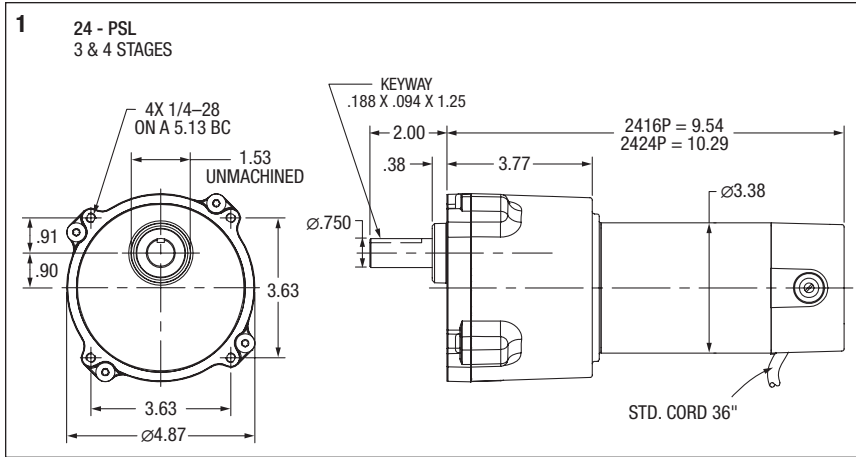

900 Series - Right Angle - Quill Type Solid Shaft

1.33 thru 3.75 CD

NEMA 56C thru 210TC

Applications: Ideal for conveyors, material handling, textile machines, packaging machinery. etc. (slow speed and high torque).

Features: Heavy duty cast iron housing, chill cast bronze gearing, precision ground hardened worm, ball bearing on input shaft, tapered roller bearings on output shaft. Industry-standard mounting dimensions. Pre-filled with food grade (H1) Klubersynth UH1-6-460 synthetic oil, sealed housing provides maintenance-free lubed for life operation.



Nominal Output RPM @ 1750 RPM In	Gear Ratio	Continuous Duty Output Torque (In-Lbs) Based on 1750 RPM Motor										Max Input Hp	Max Output Torque Rating In-Lbs	NEMA Motor Mount	Style Number	Catalog Number	List Price	Mult. Sym.	Ap'x Shpg. Wgt.	
		0.25	0.33	0.5	0.75	1	1.5	2	3	5	7.5									10
350	5:1		75	112	149								1.11	165	56C	F-913-05-B5-G	GF0513AG	457	GB	20
			75	112	149								1.11	165	56C	F-913-05-B5-J	GF0513AJ	457	GB	20
				115	154	231							1.50	231	56C	F-915-05-B5-G	GF0515AG	489	GB	25
				115	154	231							1.50	231	140TC	F-915-05-B7-G	GF0515BG	489	GB	25
				115	154	231							1.50	231	56C	F-915-05-B5-H	GF0515AH	518	GB	25
					160	240	320						2.00	320	56C	F-918-05-B5-G	GF0518AG	501	GB	30
					160	240	320						2.00	320	140TC	F-918-05-B7-G	GF0518BG	501	GB	30
						246	327	491					3.14	514	140TC	F-921-05-B7-G	GF0521BG	627	GB	35
						246	327	491					3.14	514	140TC	F-921-05-B7-J	GF0521BJ	627	GB	35
							339	507					4.17	705	180TC	F-924-05-B9-G	GF0524CG	740	GB	40
							339	508	847				5.43	919	180TC	F-926-05-B9-G	GF0526CG	858	GB	55
								502	837	1255			7.64	1279	180TC	F-930-05-B9-G	GF0530CG	1,167	GB	68
							837	1255	1674		13.7	2315	210TC	F-938-05-B11-H	GF0538DH	1,633	GB	126		
175	10:1		82	125	187							0.90	225	56C	F-913-10-B5-G	GF1013AG	457	GB	20	
			82	125	187							0.90	225	56C	F-913-10-B5-J	GF1013AJ	457	GB	20	
			82	125	187							0.90	225	56C	F-913-10-B5-H	GF1013AH	484	GB	20	
				141	211	282							1.03	290	56C	F-915-10-B5-G	GF1015AG	489	GB	20
				141	211	282							1.03	290	140TC	F-915-10-B7-G	GF1015BG	489	GB	20
				141	211	282							1.03	290	56C	F-915-10-B5-H	GF1015AH	518	GB	25
					214	285	428						1.50	428	56C	F-918-10-B5-G	GF1018AG	501	GB	30
					214	285	428						1.50	428	56C	F-918-10-B5-J	GF1018AJ	501	GB	30
					214	285	428						1.50	428	56C	F-918-10-B5-H	GF1018AH	530	GB	29
						214	285	428					1.50	428	140TC	F-918-10-B7-G	GF1018BG	501	GB	30
							312	468	624				2.02	630	56C	F-921-10-B5-G	GF1021AG	627	GB	35
							312	468	624				2.02	630	56C	F-921-10-B5-J	GF1021AJ	627	GB	35
					312	468	624				2.02	630	56C	F-921G-10-B5-G	GF10G21AG	627	GB	30		

NOTE: Service Class I Torque Ratings (1.0 Service Factor)
 Service Class II Torque Ratings (≥ 1.4 Service Factor)
 Service Class III Torque Ratings (≥ 2.0 Service Factor)

Vertical motor below gearhead not recommended.
 Avoiding those positions where the high speed oil seal is immersed in oil, will provide greater security against high speed input seal wear.
 Replacement oil - 1 Qt P/N MJ0006A05SP (Klubersynth UH1-6-460)

Assembly Types

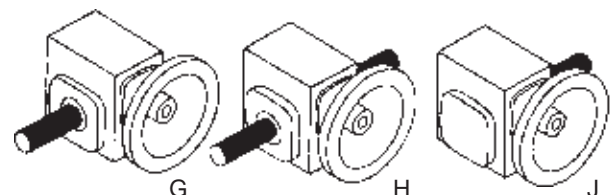

900 Series – Right Angle – Quill Type – Solid Shaft continued...

Nominal Output RPM @ 1750 RPM In	Gear Ratio	Continuous Duty Output Torque (In-Lbs) Based on 1750 RPM Motor									Max Input Hp	Max Output Torque Rating In-Lbs	NEMA Motor Mount	Style Number	Catalog Number	List Price	Mult. Sym.	Ap'x Shpg. Wgt.	
		0.25	0.33	0.5	0.75	1	1.5	2	3	5									7.5
175	10:1				312	468	624				2.02	630	56C	F-921-10-B5-H	GF1021AH	661	GB	35	
					312	468	624				2.02	630	140TC	F-921-10-B7-G	GF1021BG	627	GB	35	
					317	475	634				2.73	893	140TC	F-924-10-B7-G	GF1024BG	740	GB	40	
								655	983			3.59	1177	140TC	F-926-10-B7-G	GF1026BG	858	GB	55
								655	983			3.59	1177	180TC	F-926-10-B9-G	GF1026CG	858	GB	55
								641	961	1602		5.48	1755	180TC	F-930-10-B9-G	GF1030CG	1,167	GB	68
										990	1649	6.36	2106	180TC	F-932-10-B9-G	GF1032CG	1,265	GB	87
								963	1604	2407	9.05	2905	210TC	F-938-10-B11-G	GF1038DG	1,545	GB	126	
117	15:1	89	118	179							0.66	225	56C	F-913-15-B5-G	GF1513AG	457	GB	20	
		89	118	179							0.66	225	56C	F-913-15-B5-J	GF1513AJ	457	GB	20	
		89	118	179							0.66	225	56C	F-913-15-B5-H	GF1513AH	484	GB	20	
			127	193	289						0.81	312	56C	F-915-15-B5-G	GF1515AG	489	GB	25	
			127	193	289						0.81	312	56C	F-915-15-B5-H	GF1515AH	518	GB	25	
				209	314	419					1.07	448	56C	F-918-15-B5-G	GF1518AG	501	GB	30	
				209	314	419					1.07	448	56C	F-918-15-B5-J	GF1518AJ	501	GB	30	
				209	314	419					1.07	448	56C	F-918-15-B5-H	GF1518AH	530	GB	30	
				246	369	492					1.35	664	56C	F-921-15-B5-G	GF1521AG	627	GB	35	
				246	369	492					1.35	664	56C	F-921-15-B5-J	GF1521AJ	627	GB	35	
				246	369	492					1.35	664	56C	F-921-15-B5-H	GF1521AH	661	GB	35	
				246	369	492					1.35	664	140TC	F-921-15-B7-G	GF1521BG	627	GB	35	
							470	705	939			2.11	992	56C	F-924-15-B5-G	GF1524AG	740	GB	40
							470	705	939			2.11	992	56C	F-924-15-B5-J	GF1524AJ	740	GB	40
							470	705	939			2.11	992	140TC	F-924-15-B7-G	GF1524BG	740	GB	40
							473	710	947			2.58	1225	140TC	F-926-15-B7-G	GF1526BG	858	GB	55
								686	915	1373		4.14	1903	180TC	F-930-15-B9-G	GF1530CG	1,167	GB	68
									959	1438		4.66	2241	140TC	F-932-15-B7-G	GF1532BG	1,265	GB	87
									959	1438		4.66	2241	180TC	F-932-15-B9-G	GF1532CG	1,265	GB	87
										1409	2349	6.64	3118	180TC	F-938-15-B9-G	GF1538CG	1,545	GB	126
88	20:1	113	149	226							0.53	239	56C	F-913-20-B5-G	GF2013AG	457	GB	20	
		113	149	226							0.53	239	56C	F-913-20-B5-H	GF2013AH	484	GB	20	
		128	169	256							0.62	317	56C	F-915-20-B5-G	GF2015AG	489	GB	25	
		128	169	256							0.62	317	56C	F-915-20-B5-H	GF2015AH	518	GB	25	
			165	251	376						0.92	461	56C	F-918-20-B5-G	GF2018AG	501	GB	30	
			165	251	376						0.92	461	56C	F-918-20-B5-J	GF2018AJ	501	GB	30	
			165	251	376						0.92	461	56C	F-918-20-B5-H	GF2018AH	530	GB	30	
				323	484	645					1.06	684	56C	F-921-20-B5-G	GF2021AG	627	GB	35	
				323	484	645					1.06	684	56C	F-921-20-B5-J	GF2021AJ	627	GB	35	
				323	484	645					1.06	684	56C	F-921G-20-B5-G	GF20G21AG	627	GB	35	

NOTE: Service Class I Torque Ratings (1.0 Service Factor) See notes on inside back flap and pages 5-6.
 Service Class II Torque Ratings (≥ 1.4 Service Factor)
 Service Class III Torque Ratings (≥ 2.0 Service Factor)

Vertical motor below gearhead not recommended. Avoiding those positions where the high speed oil seal is immersed in oil, will provide greater security against high speed input seal wear.

Assembly Types

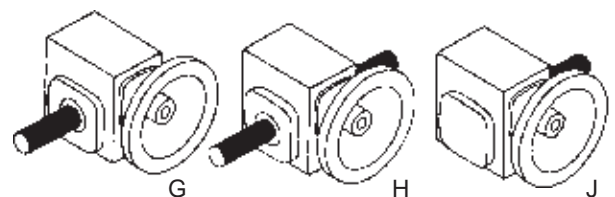

Gearmotors and Gear Products

Motor Accessories

Grinders

Generators

Servo Motors and Controls

Mod Express

Baldor Education Workshops

Warranties and Sales Policies

Cross Reference and Index

Baldor Sales Offices

900 Series - Right Angle - Quill Type - Solid Shaft continued...

Nominal Output RPM @ 1750 RPM In	Gear Ratio	Continuous Duty Output Torque (In-Lbs) Based on 1750 RPM Motor									Max Input Hp	Max Output Torque Rating In-Lbs	NEMA Motor Mount	Style Number	Catalog Number	List Price	Mult. Sym.	Ap'x Shpg. Wgt.	
		0.25	0.33	0.5	0.75	1	1.5	2	3	5									7.5
88	20:1		323	484	645							1.06	684	56C	F-921-20-B5-H	GF2021AH	661	GB	35
			323	484	645							1.06	684	140TC	F-921-20-B7-G	GF2021BG	627	GB	35
			323	484	645							1.06	684	140TC	F-921G-20-B7-G	GF20G21BG	627	GB	30
				451	602	902						1.72	1038	56C	F-924-20-B5-G	GF2024AG	740	GB	40
				451	602	902						1.72	1038	140TC	F-924-20-B7-G	GF2024BG	740	GB	40
					609	913	1218					2.15	1308	56C	F-926-20-B5-G	GF2026AG	858	GB	55
					609	913	1218					2.15	1308	140TC	F-926-20-B7-G	GF2026BG	858	GB	55
						880	1174	1761				3.31	1955	140TC	F-930-20-B7-G	GF2030BG	1,167	GB	68
						880	1174	1761				3.31	1955	180TC	F-930-20-B9-G	GF2030CG	1,167	GB	68
						880	1174	1761				3.31	1955	180TC	F-930-20-B9-J	GF2030CJ	1,167	GB	68
						924	1232	1848				3.85	2383	140TC	F-932-20-B7-G	GF2032BG	1,265	GB	87
						924	1232	1848				3.85	2383	180TC	F-932-20-B9-G	GF2032CG	1,265	GB	87
					1176	1764	2940			5.43	3193	180TC	F-938-20-B9-G	GF2038CG	1,545	GB	126		
70	25:1	119	157	238							0.50	238	56C	F-913-25-B5-G	GF2513AG	457	GB	20	
		156	206	312							0.51	318	56C	F-915-25-B5-G	GF2515AG	489	GB	25	
		156	206	312							0.51	318	56C	F-915-25-B5-H	GF2515AH	518	GB	25	
			183	277	416							0.8	444	56C	F-918-25-B5-G	GF2518AG	501	GB	28
			183	277	416							0.8	444	56C	F-918-25-B5-J	GF2518AJ	501	GB	30
			250	379	569							0.89	675	56C	F-921-25-B5-G	GF2521AG	627	GB	35
			250	379	569							0.89	675	56C	F-921-25-B5-J	GF2521AJ	627	GB	35
			250	379	569							0.89	675	56C	F-921G-25-B5-G	GF25G21AG	627	GB	40
				365	547	729						1.37	1002	56C	F-924-25-B5-G	GF2524AG	740	GB	36
				365	547	729						1.37	1002	140TC	F-924-25-B7-G	GF2524BG	740	GB	40
					567	756	1134					1.73	1307	140TC	F-926-25-B7-G	GF2526BG	858	GB	55
						711	1066	1422				2.78	1978	56C	F-930-25-B5-G	GF2530AG	1,167	GB	68
				711	1066	1422				2.78	1978	140TC	F-930-25-B7-G	GF2530BG	1,167	GB	68		
					1134	1513	2269			3.13	2355	140TC	F-932-25-B7-G	GF2532BG	1,265	GB	87		
						1440	2160			4.50	3222	180TC	F-938-25-B9-H	GF2538CH	1,633	GB	126		
58	30:1	148	195								0.42	248	56C	F-913-30-B5-G	GF3013AG	457	GB	20	
		148	195								0.42	248	56C	F-913-30-B5-H	GF3013AH	484	GB	20	
		159	210	318							0.50	318	56C	F-915-30-B5-G	GF3015AG	489	GB	25	
		159	210	318							0.50	318	56C	F-915-30-B5-H	GF3015AH	518	GB	25	
			216	327								0.72	470	56C	F-918-30-B5-G	GF3018AG	501	GB	30
			216	327								0.72	470	56C	F-918-30-B5-J	GF3018AJ	501	GB	30
			216	327								0.72	470	56C	F-918-30-B5-H	GF3018AH	530	GB	30
			275	416	624							0.83	691	56C	F-921-30-B5-G	GF3021AG	627	GB	35
			275	416	624							0.83	691	56C	F-921-30-B5-J	GF3021AJ	627	GB	35
			275	416	624							0.83	691	56C	F-921-30-B5-H	GF3021AH	661	GB	35
			275	416	624							0.83	691	56C	F-921G-30-B5-G	GF30G21AG	627	GB	30
				420	630	840						1.32	1111	56C	F-924-30-B5-G	GF3024AG	740	GB	40
		420	630	840						1.32	1111	56C	F-924-30-B5-J	GF3024AJ	740	GB	40		
		420	630	840						1.32	1111	140TC	F-924-30-B7-G	GF3024BG	740	GB	40		
			641	854	1281					1.54	1313	56C	F-926-30-B5-G	GF3026AG	858	GB	55		
			641	854	1281					1.54	1313	140TC	F-926-30-B7-G	GF3026BG	858	GB	55		
				804	1206	1608				2.47	1978	56C	F-930-30-B5-G	GF3030AG	1,167	GB	68		
				804	1206	1608				2.47	1978	56C	F-930-30-B5-J	GF3030AJ	1,167	GB	68		
				804	1206	1608				2.47	1978	140TC	F-930-30-B7-G	GF3030BG	1,167	GB	68		
				881	1322	1763				2.81	2482	140TC	F-932-30-B7-G	GF3032BG	1,265	GB	87		
					1626	2438				3.97	3226	180TC	F-938-30-B9-G	GF3038CG	1,545	GB	126		

NOTE: Refer to Brochure CA1600 for Dimensions and Engineering Information.

See notes on inside back flap and pages 5-6.

- Service Class I Torque Ratings (1.0 Service Factor)
- Service Class II Torque Ratings (≥ 1.4 Service Factor)
- Service Class III Torque Ratings (≥ 2.0 Service Factor)

Vertical motor below gearhead not recommended.

Avoiding those positions where the high speed oil seal is immersed in oil, will provide greater security against high speed input seal wear.

900 Series – Right Angle – Quill Type – Solid Shaft continued...

Nominal Output RPM @ 1750 RPM In	Gear Ratio	Continuous Duty Output Torque (In-Lbs) Based on 1750 RPM Motor										Max Input Hp	Max Output Torque Rating In-Lbs	NEMA Motor Mount	Style Number	Catalog Number	List Price	Mult. Sym.	Ap'x Shpg. Wgt.
		0.25	0.33	0.5	0.75	1	1.5	2	3	5	7.5								
44	40:1	174	230									0.33	230	56C	F-913-40-BG-G	GF4013AG	457	GB	20
		174	230									0.33	230	56C	F-913-40-B5-H	GF4013AH	484	GB	20
		208	275									0.38	317	56C	F-915-40-B5-G	GF4015AG	489	GB	25
		208	275									0.38	317	56C	F-915-40-B5-J	GF4015AJ	489	GB	25
		180	238	360								0.64	461	56C	F-918-40-B5-G	GF4018AG	501	GB	30
		180	238	360								0.64	461	56C	F-918-40-B5-J	GF4018AJ	501	GB	30
				340	515							0.66	680	56C	F-921-40-B5-G	GF4021AG	627	GB	35
				340	515							0.66	680	56C	F-921-40-B5-J	GF4021AJ	627	GB	35
					521	781						0.99	1030	56C	F-924-40-B5-G	GF4024AG	740	GB	40
					521	781						0.99	1030	56C	F-924-40-B5-J	GF4024AJ	740	GB	40
					521	781						0.99	1030	56C	F-924-40-B5-H	GF4024AH	782	GB	40
					524	786	1049					1.23	1296	56C	F-926-40-B5-G	GF4026AG	858	GB	55
					524	786	1049					1.23	1296	56C	F-926-40-B5-J	GF4026AJ	858	GB	55
					524	786	1049					1.23	1296	140TC	F-926-40-B7-G	GF4026BG	858	GB	55
						794	1059	1589				1.84	1960	56C	F-930-40-B5-G	GF4030AG	1,167	GB	68
						794	1059	1589				1.84	1960	140TC	F-930-40-B7-G	GF4030BG	1,167	GB	68
							1180	1620	2160			2.20	2374	140TC	F-932-40-B7-G	GF4032BG	1,265	GB	87
								1596	2129	3192		3.00	3192	180TC	F-938-40-B9-G	GF4038CG	1,545	GB	126
								1596	2129	3192		3.00	3192	180TC	F-938-40-B9-H	GF4038CH	1,633	GB	126
		35	50:1	177	234								0.33	234	56C	F-913-50-B5-G	GF5013AG	457	GB
177	234										0.33	234	56C	F-913-50-B5-H	GF5013AH	484	GB	20	
230	303										0.33	303	56C	F-915-50-B5-G	GF5015AG	489	GB	25	
222	294										0.49	436	56C	F-918-50-B5-G	GF5018AG	501	GB	30	
222	294										0.49	436	56C	F-918-50-B5-J	GF5018AJ	501	GB	30	
280	370			561								0.58	651	56C	F-921-50-B5-G	GF5021AG	627	GB	35
280	370			561								0.58	651	56C	F-921-50-B5-J	GF5021AJ	627	GB	35
280	370			561								0.58	651	56C	F-921-50-B5-H	GF5021AH	661	GB	35
				401	608	912						0.83	1014	56C	F-924-50-B5-G	GF5024AG	740	GB	40
					621	932	1242					1.00	1242	56C	F-926-50-B5-G	GF5026AG	858	GB	55
					621	932	1242					1.00	1242	140TC	F-926-50-B7-G	GF5026BG	858	GB	55
						850	1134	1701				1.67	1890	56C	F-930-50-B5-G	GF5030AG	1,167	GB	68
						850	1134	1701				1.67	1890	140TC	F-930-50-B7-G	GF5030BG	1,167	GB	68
						958	1278	1917				1.83	2366	56C	F-932-50-B5-G	GF5032AG	1,265	GB	87
						958	1278	1917				1.83	2366	140TC	F-932-50-B7-G	GF5032BG	1,265	GB	87
							1152	1729	2305			2.67	3076	140TC	F-938-50-B7-G	GF5038BG	1,545	GB	126
					1152	1729	2305			2.67	3076	140TC	F-938-50-B7-H	GF5038BH	1,633	GB	126		
29	60:1	218	288								0.33	288	56C	F-915-60-B5-G	GF6015AG	489	GB	25	
		218	288								0.33	288	56C	F-915-60-B5-H	GF6015AH	518	GB	25	
		220	290								0.47	413	56C	F-918-60-B5-G	GF6018AG	501	GB	30	
		220	290								0.47	413	56C	F-918-60-B5-J	GF6018AJ	501	GB	30	
		220	290								0.47	413	56C	F-918-60-B5-H	GF6018AH	530	GB	30	

NOTE: Service Class I Torque Ratings (1.0 Service Factor) See notes on inside back flap and pages 5-6.
 Service Class II Torque Ratings (≥ 1.4 Service Factor)
 Service Class III Torque Ratings (≥ 2.0 Service Factor)

Vertical motor below gearhead not recommended.
 Avoiding those positions where the high speed oil seal is immersed in oil, will provide greater security against high speed input seal wear.

Gearmotors and Gear Products

Motor Accessories

Grinders

Generators

Servo Motors and Controls

Mod Express

Baldor Education Workshops

Warranties and Sales Policies

Cross Reference and Index

Baldor Sales Offices

900 Series - Right Angle - Quill Type - Solid Shaft continued...

Nominal Output RPM @ 1750 RPM In	Gear Ratio	Continuous Duty Output Torque (In-Lbs) Based on 1750 RPM Motor										Max Input Hp	Max Output Torque Rating In-Lbs	NEMA Motor Mount	Style Number	Catalog Number	List Price	Mult. Sym.	Ap'x Shpg. Wgt.
		0.25	0.33	0.5	0.75	1	1.5	2	3	5	7.5								
29	60:1	317	418	634								0.50	634	56C	F-921-60-B5-G	GF6021AG	627	GB	35
		317	418	634								0.50	634	56C	F-921-60-B5-H	GF6021AH	661	GB	35
		317	418	634								0.50	634	56C	F-921-60-B5-J	GF6021AJ	627	GB	35
			458	693								0.69	958	56C	F-924-60-B5-G	GF6024AG	740	GB	40
			458	693								0.69	958	56C	F-924-60-B5-J	GF6024AJ	740	GB	40
			473	716	1074							0.82	1166	56C	F-926-60-B5-G	GF6026AG	858	GB	55
			473	716	1074							0.82	1166	56C	F-926-60-B5-J	GF6026AJ	858	GB	55
			473	716	1074							0.82	1166	56C	F-926-60-B5-H	GF6026AH	904	GB	55
					896	1195	1795					1.50	1795	56C	F-930-60-B5-G	GF6030AG	1,167	GB	68
					896	1195	1795					1.50	1795	140TC	F-930-60-B7-G	GF6030BG	1,167	GB	68
					1100	1467	2200					1.54	2255	56C	F-932-60-B5-G	GF6032AG	1,265	GB	87
					1100	1467	2200					1.54	2255	140TC	F-932-60-B7-G	GF6032BG	1,265	GB	87
						1254	1881	2508				2.33	2921	140TC	F-938-60-B7-G	GF6038BG	1,545	GB	126
						1254	1881	2508				2.33	2921	140TC	F-938-60-B7-H	GF6038BH	1,633	GB	126

NOTE: Service Class I Torque Ratings (1.0 Service Factor)
 Service Class II Torque Ratings (≥ 1.4 Service Factor)
 Service Class III Torque Ratings (≥ 2.0 Service Factor)

See notes on inside back flap and pages 5-6.

Suffix G = Left hand output facing input
 J = Right hand output facing input
 H = Double Output Shaft

Vertical motor below gearhead not recommended.

Avoiding those positions where the high speed oil seal is immersed in oil, will provide greater security against high speed input seal wear.

Assembly Types

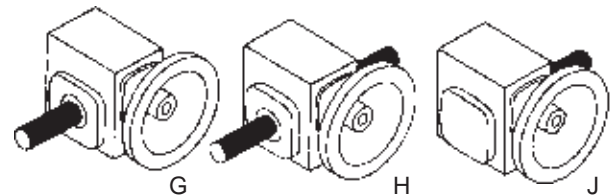

900 Series – Right Angle – Quill Type Hollow Shaft



1.33 thru 3.25 CD

56C thru 180TC

Applications: Ideal for conveyors, material handling, textile machines, packaging machinery. etc. (slow speed and high torque).

Features: Heavy duty cast iron housing, chill cast bronze gearing, precision ground hardened worm, ball bearing on input shaft, tapered roller bearings on output shaft. Industry-standard mounting dimensions. Pre-filled with food grade (H1) Klubersynth UH1-6-460 synthetic oil, sealed housing provides maintenance-free lubed for life operation.

Nominal Output RPM @ 1750 RPM In	Gear Ratio	Continuous Duty Output Torque (In-Lbs) Based on 1750 RPM Motor									Max Input Hp	Max Output Torque Rating In-Lbs	NEMA Motor Mount	Style Number	Catalog Number	List Price	Mult. Sym.	Ap'x Shpg. Wgt.	
		0.25	0.33	0.5	0.75	1	1.5	2	3	5									7.5
350	5:1		75	112	149							1.00	165	56C	HF-913-05-B5-H	GHF0513AH	602	GB	20
						160	240	320				2.00	320	56C	HF-918-05-B5-H	GHF0518AH	644	GB	30
175	10:1			214	285	428						1.50	428	56C	HF-918-10-B5-H	GHF1018AH	644	GB	30
						312	468	624				2.02	630	56C	HF-921-10-B5-H	GHF1021AH	765	GB	35
117	15:1						641	961	1602			5.48	1755	180TC	HF-930-10-B9-H	GHF1030CH	1,387	GB	75
		89	118	179								0.66	25	56C	HF-913-15-B5-H	GHF1513AH	602	GB	20
				209	314	419						1.07	448	56C	HF-918-15-B5-H	GHF1518AH	644	GB	30
				246	369	492						1.35	664	56C	HF-921-15-B5-H	GHF1521AH	765	GB	35
						470	705	939				2.11	992	56C	HF-924-15-B5-H	GHF1524AH	919	GB	45
88	20:1						686	915	1373			4.14	1903	140TC	HF-930-15-B7-H	GHF1530BH	1,387	GB	75
		113	149	226								0.53	239	56C	HF-913-20-B5-H	GHF2013AH	602	GB	20
			165	251	376							0.92	461	56C	HF-918-20-B5-H	GHF2018AH	644	GB	30
				323	484	645						1.06	684	56C	HF-921-20-B5-H	GHF2021AH	765	GB	35
					451	602	902					1.72	1038	56C	HF-924-20-B5-H	GHF2024AH	919	GB	45
70	25					609	913	1218			2.15	1309	56C	HF-926-20-B5-H	GHF2026AH	1,085	GB	56	
							880	1174	1761			3.31	1955	140TC	HF-930-20-B7-H	GHF2030BH	1,387	GB	75
		183	277	416								0.80	444	56C	HF-918-25-B5-H	GHF2518AH	644	GB	23
			250	379	569							0.89	675	56C	HF-921-25-B5-H	GHF2521AH	765	GB	32
				567	756	1134						1.73	1307	140TC	HF-926-25-B7-H	GHF2526BH	1,085	GB	44
58	30:1										2.78	1978	140TC	HF-930-25-B7-H	GHF2530BH	1,387	GB	88	
		148	195									0.42	248	56C	HF-913-30-B5-H	GHF3013AH	602	GB	20
			216	327								0.72	470	56C	HF-918-30-B5-H	GHF3018AH	644	GB	30
			275	416	624							0.83	691	56C	HF-921-30-B5-H	GHF3021AH	765	GB	35
				420	630	840						1.32	1111	56C	HF-924-30-B5-H	GHF3024AH	919	GB	45
44	40:1										1.54	1313	56C	HF-926-30-B5-H	GHF3026AH	1,085	GB	56	
						804	1206	1608				2.47	1978	140TC	HF-930-30-B7-H	GHF3030BH	1,387	GB	75
						881	1322	1763				2.81	2462	140TC	HF-932-30-B7-H	GHF3032BH	1,503	GB	95
		180	238	360								0.64	461	56C	HF-918-40-B5-H	GHF4018AH	644	GB	30
			340	515								0.66	680	56C	HF-921-40-B5-H	GHF4021AH	765	GB	35
35	50:1										0.99	1030	56C	HF-924-40-B5-H	GHF4024AH	919	GB	45	
						524	786	1049				1.23	1296	56C	HF-926-40-B5-H	GHF4026AH	1,085	GB	56
						524	786	1049				1.23	1296	140TC	HF-926-40-B7-H	GHF4026BH	1,085	GB	56
							1074	1611	2148			2.20	2374	140TC	HF-932-40-B7-H	GHF4032BH	1,503	GB	95
		177	234									0.33	234	56C	HF-913-50-B5-H	GHF5013AH	602	GB	20
29	60:1										0.49	436	56C	HF-918-50-B5-H	GHF5018AH	644	GB	30	
						280	370	561				0.58	651	56C	HF-921-50-B5-H	GHF5021AH	765	GB	35
						401	608	912				0.83	1014	56C	HF-924-50-B5-H	GHF5024AH	919	GB	45
							850	1134	1701			1.67	1890	56C	HF-930-50-B5-H	GHF5030AH	1,387	GB	75
							958	1278	1917			1.83	2366	56C	HF-932-50-B5-H	GHF5032AH	1,503	GB	95
29	60:1										0.47	413	56C	HF-918-60-B5-H	GHF6018AH	644	GB	30	
						317	418	634				0.50	634	56C	HF-921-60-B5-H	GHF6021AH	765	GB	35
						458	693					0.69	958	56C	HF-924-60-B5-H	GHF6024AH	919	GB	45
						473	716	1074				0.82	1166	56C	HF-926-60-B5-H	GHF6026AH	1,085	GB	56
							896	1195	1795			1.50	1795	56C	HF-930-60-B5-H	GHF6030AH	1,387	GB	75
					1100	1467	2200			1.54	2255	56C	HF-932-60-B5-H	GHF6032AH	1,503	GB	95		

NOTE: Service Class I Torque Ratings (1.0 Service Factor)
 Service Class II Torque Ratings (≥ 1.4 Service Factor)
 Service Class III Torque Ratings (≥ 2.0 Service Factor)

See notes on inside back flap and pages 5-6.

Vertical motor below gearhead not recommended

Avoiding those positions where the high speed oil seal is immersed in oil, will provide greater security against high speed input seal wear.

Stainless Steel - Right Angle - Quill Type Solid Shaft

1.75 thru 2.62 CD

56C thru 140TC

Applications: Baldor's all stainless speed reducers are easy to clean and sanitize, minimizing bacterial contamination for food processing equipment. Stainless steel provides the high protection for pharmaceutical and chemical processing applications where harsh chemicals and cleaning solutions can be extremely corrosive to aluminum, cast iron and other materials.

Features: Housing and covers are cast stainless steel to endure hostile environments. 300 Series stainless output shafts and all stainless steel hardware for long rust resistant life. O-ring sealed housing and motor interface helps keeps contaminants out. Pre-filled with food grade (H1) Klubersynth UH1-6-460 synthetic oil. Sealed housing provides maintenance-free lubed for life operation. BISSC certified (Baking Industry Sanitation Standards Committee).



Nominal Output RPM @ 1750 RPM In	Gear Ratio	Continuous Duty Output Torque (In-Lbs) Based on 1750 RPM Motor										Max Input Hp	Max Output Torque Rating In-Lbs	NEMA Motor Mount	Style Number	Catalog Number	List Price	Mult. Sym.	Ap'x Shpg. Wgt.		
		0.25	0.33	0.5	0.75	1	1.5	2	3	5	7.5										
350	5:1					160	240	320					2.00	320	56C	SSF-918-05-B5-G	SSGF0518AG	1,553	GB	30	
						160	240	320					2.00	320	140TC	SSF-918-05-B7-G	SSGF0518BG	1,553	GB	30	
							246	327	491					3.14	514	140TC	SSF-921-05-B7-G	SSGF0521BG	1,817	GB	35
								339	508	847				5.43	919	140TC	SSF-926-05-B7-G	SSGF0526BG	2,556	GB	65
175	10:1			214	285	428							1.50	428	56C	SSF-918-10-B5-G	SSGF1018AG	1,553	GB	30	
				214	285	428							1.50	428	140TC	SSF-918-10-B7-G	SSGF1018BG	1,553	GB	30	
						312	468	624						2.02	630	140TC	SSF-921-10-B7-G	SSGF1021BG	1,817	GB	35
								655	983					3.59	1177	140TC	SSF-926-10-B7-G	SSGF1026BG	2,556	GB	65
117	15:1		209	314	419								1.07	448	56C	SSF-918-15-B5-G	SSGF1518AG	1,553	GB	30	
			246	369	492								1.35	664	56C	SSF-921-15-B5-G	SSGF1521AG	1,817	GB	35	
						473	710	947					2.58	1225	140TC	SSF-926-15-B7-G	SSGF1526BG	2,556	GB	65	
88	20:1		165	251	376								0.92	461	56C	SSF-918-20-B5-G	SSGF2018AG	1,553	GB	30	
				323	484	645							1.06	684	56C	SSF-921-20-B5-G	SSGF2021AG	1,817	GB	35	
						609	913	1218					2.15	1308	140TC	SSF-926-20-B7-G	SSGF2026BG	2,556	GB	65	
70	25:1		183	277	416								0.80	444	56C	SSF-918-25-B5-G	SSGF2518AG	1,553	GB	30	
			250	379	569								0.89	675	56C	SSF-921-25-B5-G	SSGF2521AG	1,817	GB	35	
						567	756	1134					1.73	1307	140TC	SSF-926-25-B7-G	SSGF2526BG	2,556	GB	65	
58	30:1		216	327									0.72	470	56C	SSF-918-30-B5-G	SSGF3018AG	1,553	GB	30	
			275	416	624								0.83	691	56C	SSF-921-30-B5-G	SSGF3021AG	1,817	GB	35	
						641	854	1281					1.54	1313	140TC	SSF-926-30-B7-G	SSGF3026BG	2,556	GB	65	
44	40:1	180	238	360								0.64	461	56C	SSF-918-40-B5-G	SSGF4018AG	1,553	GB	30		
			340	515									0.66	680	56C	SSF-921-40-B5-G	SSGF4021AG	1,817	GB	35	
						524	786	1049					1.23	1296	140TC	SSF-926-40-B7-G	SSGF4026BG	2,556	GB	65	
35	50:1	222	294									0.49	436	56C	SSF-918-50-B5-G	SSGF5018AG	1,553	GB	30		
			280	370	561								0.58	651	56C	SSF-921-50-B5-G	SSGF5021AG	1,817	GB	35	
						621	932	1242					1.00	1242	56C	SSF-926-50-B5-G	SSGF5026AG	2,556	GB	65	
29	60:1	220	290									0.47	413	56C	SSF-918-60-B5-G	SSGF6018AG	1,553	GB	30		
			317	418	634								0.50	634	56C	SSF-921-60-B5-G	SSGF6021AG	1,817	GB	35	
						473	716	1074					0.82	1166	56C	SSF-926-60-B5-G	SSGF6026AG	2,556	GB	65	

NOTE: Service Class I Torque Ratings (1.0 Service Factor) Service Class II Torque Ratings (≥ 1.4 Service Factor) Service Class III Torque Ratings (≥ 2.0 Service Factor)

Refer to Brochure CA1600 for Dimensions and Engineering Information. See notes on inside back flap and pages 5-6.

Vertical motor below gearhead not recommended.
 Avoiding those positions where the high speed oil seal is immersed in oil, will provide greater security against high speed input seal wear.
 Horizontal bases, SSB18H71, SSB21H71 and SSB26H71, are available, see page 383.

Stainless Steel – Right Angle – Quill Type Hollow Shaft



SSGHF2026AH Shown

1.75 thru 2.62 CD

56C thru 140TC

Applications: Baldor's all stainless speed reducers are easy to clean and sanitize, minimizing bacterial contamination for food processing equipment. Stainless steel provides the high protection for pharmaceutical and chemical processing applications where harsh chemicals and cleaning solutions can be extremely corrosive to aluminum, cast iron and other materials.

Features: Housing and covers are cast stainless steel to endure hostile environments. 300 Series stainless output shafts and all stainless steel hardware for long rust resistant life. O-ring sealed housing and motor interface helps keeps contaminants out. Pre-filled with food grade (H1) Klubersynth UH1-6-460 synthetic oil. Sealed housing provides maintenance-free lubed for life operation. BISSC certified (Baking Industry Sanitation Standards Committee).

Nominal Output RPM @ 1750 RPM In	Gear Ratio	Continuous Duty Output Torque (In-Lbs) Based on 1750 RPM Motor										Max Input Hp	Max Output Torque Rating In-Lbs	NEMA Motor Mount	Style Number	Catalog Number	List Price	Mult. Sym.	Ap'x Shpg. Wgt.
		0.25	0.33	0.5	0.75	1	1.5	2	3	5	7.5								
350	5:1					160	240	320				2.00	320	56C	SSHF-918-05-B5-H	SSGHF0518AH	1,640	GB	30
175	10:1				214	285	428					1.50	428	56C	SSHF-918-10-B5-H	SSGHF1018AH	1,640	GB	30
						312	468	624				2.20	630	56C	SSHF-921-10-B5-H	SSGHF1021AH	1,900	GB	38
117	15:1			209	314	419						1.07	448	56C	SSHF-918-15-B5-H	SSGHF1518AH	1,640	GB	30
				246	369	492						1.35	664	56C	SSHF-921-15-B5-H	SSGHF1521AH	1,900	GB	38
88	20:1		165	251	376							0.92	461	56C	SSHF-918-20-B5-H	SSGHF2018AH	1,640	GB	30
				323	484	645						1.06	684	56C	SSHF-921-20-B5-H	SSGHF2021AH	1,900	GB	38
						609	913	1218				2.15	1309	56C	SSHF-926-20-B5-H	SSGHF2026AH	2,734	GB	60
58	30:1		216	327								0.72	470	56C	SSHF-918-30-B5-H	SSGHF3018AH	1,640	GB	30
			275	416	624							0.83	691	56C	SSHF-921-30-B5-H	SSGHF3021AH	1,900	GB	38
					641	854	1281					1.54	1313	56C	SSHF-926-30-B5-H	SSGHF3026AH	2,734	GB	60
44	40:1	180	238	360								0.64	461	56C	SSHF-918-40-B5-H	SSGHF4018AH	1,640	GB	30
			340	515								0.66	680	56C	SSHF-921-40-B5-H	SSGHF4021AH	1,900	GB	38
				524	786	1049						1.23	1296	56C	SSHF-926-40-B5-H	SSGHF4026AH	2,734	GB	60
				524	786	1049						1.23	1296	140TC	SSHF-926-40-B7-H	SSGHF4026BH	2,734	GB	60
35	50:1	222	294									0.49	436	56C	SSHF-918-50-B5-H	SSGHF5018AH	1,640	GB	30
		280	370	561								0.58	651	56C	SSHF-921-50-B5-H	SSGHF5021AH	1,900	GB	38
				621	932	1242						1.00	1242	56C	SSHF-926-50-B5-H	SSGHF5026AH	2,734	GB	53
29	60:1	220	290									0.47	413	56C	SSHF-918-60-B5-H	SSGHF6018AH	1,640	GB	30
		317	418	634								0.50	634	56C	SSHF-921-60-B5-H	SSGHF6021AH	1,900	GB	38
			473	716	1074							0.82	1166	56C	SSHF-926-60-B5-H	SSGHF6026AH	2,734	GB	60

NOTE: Service Class I Torque Ratings (1.0 Service Factor)
 Service Class II Torque Ratings (≥ 1.4 Service Factor)
 Service Class III Torque Ratings (≥ 2.0 Service Factor)

Refer to Brochure CA1600 for Dimensions and Engineering Information.
 See notes on inside back flap and pages 5-6.

Vertical motor below gearhead not recommended.
 Avoiding those positions where the high speed oil seal is immersed in oil, will provide greater security against high speed input seal wear.
 Horizontal bases, SSB18H71, SSB21H71 and SSB26H71, are available, see page 383.

Washdown - Right Angle - Quill Type Solid Shaft

1.33 thru 3.25 CD

56C thru 140TC

Applications: Food processing and other applications regularly exposed to high pressure washdown.

Features: Epoxy coated, heavy-duty cast iron housing. Stainless steel output shaft and hardware. Sealed housing, provides maintenance-free, lubed for life operation. Pre-filled with food grade (H1) Klubersynth synthetic oil. Industry standard mounting dimensionally interchangeable with many other worm gear reducers. BISSC certified (Baking Industry Sanitation Standards Committee).



WDGF1018AG Shown

Nominal Output RPM @ 1750 RPM In	Gear Ratio	Continuous Duty Output Torque (In-Lbs) Based on 1750 RPM Motor									Max Input Hp	Max Output Torque Rating In-Lbs	NEMA Motor Mount	Style Number	Catalog Number	List Price	Mult. Sym.	Ap'x Shpg. Wgt.
		0.25	0.33	0.5	0.75	1	1.5	2	3	5								
350	5:1					160	240	320			2.00	320	56C	WDF-918-05-B5-G	WDGF0518AG	613	GB	30
175	10:1		82	125	187						0.90	225	56C	WDF-913-10-B5-G	WDGF1013AG	570	GB	20
				141	211	282					1.03	290	56C	WDF-915-10-B5-G	WDGF1015AG	602	GB	25
				141	211	282					1.03	290	140TC	WDF-915-10-B7-G	WDGF1015BG	602	GB	25
					214	285	428				1.50	428	56C	WDF-918-10-B5-G	WDGF1018AG	613	GB	30
						312	468	624			2.20	630	56C	WDF-921-10-B5-G	WDGF1021AG	755	GB	35
						317	475	634			2.73	893	140TC	WDF-924-10-B7-G	WDGF1024BG	884	GB	40
117	15:1	89	118	179							0.66	225	56C	WDF-913-15-B5-G	WDGF1513AG	570	GB	20
			127	193	289						0.81	312	56C	WDF-915-15-B5-G	WDGF1515AG	602	GB	25
				209	314	419					1.07	448	56C	WDF-918-15-B5-G	WDGF1518AG	613	GB	30
				246	369	492					1.35	664	56C	WDF-921-15-B5-G	WDGF1521AG	755	GB	35
						470	705	939			2.11	992	56C	WDF-924-15-B5-G	WDGF1524AG	884	GB	40
88	20:1	113	149	226							0.53	239	56C	WDF-913-20-B5-G	WDGF2013AG	570	GB	20
		128	169	256							0.62	317	56C	WDF-915-20-B5-G	WDGF2015AG	602	GB	25
			165	251	376						0.92	461	56C	WDF-918-20-B5-G	WDGF2018AG	613	GB	30
						609	913	1218			2.15	1309	140TC	WDF-926-20-B7-G	WDGF2026BG	1,010	GB	55
58	30:1		216	327							0.72	470	56C	WDF-918-30-B5-G	WDGF3018AG	613	GB	30
			275	416	624						0.83	691	56C	WDF-921-30-B5-G	WDGF3021AG	755	GB	35
				420	630	840					1.32	111	56C	WDF-924-30-B5-G	WDGF3024AG	884	GB	40
					641	854	1281				1.54	1313	56C	WDF-926-30-B5-G	WDGF3026AG	1,010	GB	55
						881	1322	1763			2.81	2462	140TC	WDF-932-30-B7-G	WDGF3032BG	1,483	GB	87
44	40:1	208	275								0.44	317	56C	WDF-915-40-B5-G	WDGF4015AG	602	GB	25
		180	238	360							0.64	461	56C	WDF-918-40-B5-G	WDGF4018AG	613	GB	30
			340	515							0.66	680	56C	WDF-921-40-B5-G	WDGF4021AG	755	GB	35
				521	781						0.99	1030	56C	WDF-924-40-B5-G	WDGF4024AG	884	GB	40
				524	786	1049					1.23	1296	56C	WDF-926-40-B5-G	WDGF4026AG	1,010	GB	55
						1081	1622	2163			2.20	2374	140TC	WDF-932-40-B7-G	WDGF4032BG	1,483	GB	87
35	50:1	177	234								0.33	234	56C	WDF-913-50-B5-G	WDGF5013AG	570	GB	20
		230	303								0.33	303	56C	WDF-915-50-B5-G	WDGF5015AG	602	GB	25
		280	370	561							0.58	651	56C	WDF-921-50-B5-G	WDGF5021AG	755	GB	35
			401	608	912						0.83	1014	56C	WDF-924-50-B5-G	WDGF5024AG	884	GB	40
				621	932	1242					1.00	1242	56C	WDF-926-50-B5-G	WDGF5026AG	1,010	GB	55
					958	1278	1917				1.83	2366	140TC	WDF-932-50-B7-G	WDGF5032BG	1,483	GB	92
29	60:1	218	288								0.33	288	56C	WDF-915-60-B5-G	WDGF6015AG	602	GB	25
		220	290								0.47	413	56C	WDF-918-60-B5-G	WDGF6018AG	613	GB	30
		317	418	634							0.50	634	56C	WDF-921-60-B5-G	WDGF6021AG	755	GB	35
			458	693							0.69	956	56C	WDF-924-60-B5-G	WDGF6024AG	884	GB	40
			473	716	1074						0.82	1166	56C	WDF-926-60-B5-G	WDGF6026AG	1,010	GB	55
					1100	1467	2200				1.54	2255	56C	WDF-932-60-B5-G	WDGF6032AG	1,483	GB	87

NOTE: Service Class I Torque Ratings (1.0 Service Factor)
 Service Class II Torque Ratings (≥ 1.4 Service Factor)
 Service Class III Torque Ratings (≥ 2.0 Service Factor)

See notes on inside back flap and pages 5-6.

Vertical motor below gearhead not recommended.
 Avoiding those positions where the high speed oil seal is immersed in oil, will provide greater security against high speed input seal wear.

900 Series – Right Angle – Coupling Type – Solid Shaft



GLF1018AG Shown

1.33 thru 3.75 CD

56C thru 180TC

Applications: Ideal for conveyors, material handling, textile machines, packaging machinery, etc. (slow speed and high torque).

Features: Heavy duty cast iron housings, chill cast bronze gears, precision ground hardened worm, ball bearings on input shaft, tapered roller bearings on output shaft. Industry-standard mounting dimensions. Pre-filled with food grade (H1) Klubersynth UH1-6-460 synthetic oil, sealed housing provides maintenance-free lubed for life operation. Motor coupling included.

Nominal Output RPM @ 1750 RPM In	Gear Ratio	Continuous Duty Output Torque (In-Lbs) Based on 1750 RPM Motor										Max Input Hp	Max Output Torque Rating In-Lbs	NEMA Motor Mount	Style Number	Catalog Number	List Price	Mult. Sym.	Ap'x Shpg. Wgt.	
		0.25	0.33	0.5	0.75	1	1.5	2	3	5	7.5									
350	5:1				115	154	231					1.50	231	56C	LF-915-05-B5-G	GLF0515AG	509	GB	30	
223	7.5:1				237	356	474					2.70	640	56C	LF-921-7.5-B5-G	GLF0821AG	644	GB	38	
					237	356	474					2.70	640	56C	LF-921-7.5-B5-J	GLF0821AJ	644	GB	38	
					237	356	474					2.70	640	140TC	LF-921-7.5-B7-G	GLF0821BG	644	GB	38	
								501	752			4.30	1079	140TC	LF-926-7.5-B7-G	GLF0826BG	884	GB	60	
175	10:1											4.30	1079	180TC	LF-926-7.5-B9-G	GLF0826CG	884	GB	60	
					214	285	428					1.50	428	56C	LF-918-10-B5-G	GLF1018AG	522	GB	32	
							312	468	624			2.02	630	56C	LF-921-10-B5-G	GLF1021AG	644	GB	38	
							312	468	624			2.02	630	140TC	LF-921-10-B7-G	GLF1021BG	644	GB	38	
							312	468	624			2.02	630	140TC	LF-921-10-B7-J	GLF1021BJ	644	GB	38	
							317	475	634			2.73	893	140TC	LF-924-10-B7-G	GLF1024BG	757	GB	45	
									655	983			3.59	1177	140TC	LF-926-10-B7-G	GLF1026BG	884	GB	60
									655	983			3.59	1177	180TC	LF-926-10-B9-G	GLF1026CG	884	GB	60
117	15:1											6.36	2106	180TC	LF-932-10-B9-G	GLF1032CG	1,289	GB	100	
		89	118	179								0.66	2228	56C	LF-913-15-B5-G	GLF1513AG	468	GB	20	
					246	369	492					1.35	664	56C	LF-921-15-B5-G	GLF1521AG	644	GB	38	
					246	369	492					1.35	664	56C	LF-921-15-B5-J	GLF1521AJ	644	GB	38	
							473	710	947			2.58	1225	140TC	LF-926-15-B7-G	GLF1526BG	884	GB	60	
							473	710	947			2.58	1225	140TC	LF-926-15-B7-J	GLF1526BJ	884	GB	60	
									959	1438			4.66	2241	180TC	LF-932-15-B9-G	GLF1532CG	1,289	GB	100
									959	1438			4.66	2241	180TC	LF-932-15-B9-J	GLF1532CJ	1,289	GB	100
88	20:1											6.64	3118	180TC	LF-938-15-B9-G	GLF1538CG	1,574	GB	130	
		113	149	226								0.53	239	56C	LF-913-20-B5-G	GLF2013AG	468	GB	20	
			165	251	376							0.92	464	56C	LF-918-20-B5-G	GLF2018AG	522	GB	32	
			323	484	645						1.06	684	56C	LF-921-20-B5-G	GLF2021AG	644	GB	38		

NOTE: Service Class I Torque Ratings (1.0 Service Factor)
 Service Class II Torque Ratings (≥ 1.4 Service Factor)
 Service Class III Torque Ratings (≥ 2.0 Service Factor)

Optional Shaft Positions, Base Installation and Motor Mounting available through Mod Express. Refer to a Baldor District Office for pricing and delivery. See notes on inside back flap and pages 5-6.

Vertical motor below gearhead not recommended. Avoiding those positions where the high speed oil seal is immersed in oil, will provide greater security against high speed input seal wear.

Assembly Types

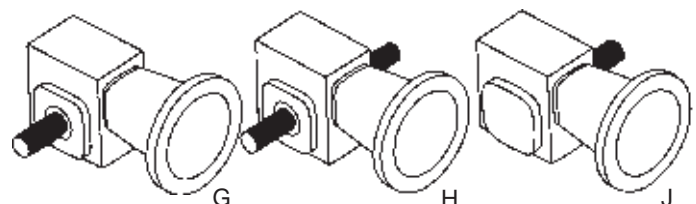

900 Series - Right Angle - Coupling Type - Solid Shaft continued...

Nominal Output RPM @ 1750 RPM In	Gear Ratio	Continuous Duty Output Torque (In-Lbs) Based on 1750 RPM Motor										Max Input Hp	Max Output Torque Rating In-Lbs	NEMA Motor Mount	Style Number	Catalog Number	List Price	Mult. Sym.	Ap'x Shpg. Wgt.	
		0.25	0.33	0.5	0.75	1	1.5	2	3	5	7.5									
88	20:1		323	484	645							1.06	684	56C	LF-921-20-B5-J	GLF2021AJ	644	GB	38	
					609	913	1218					2.15	1308	140TC	LF-926-20-B7-G	GLF2026BG	884	GB	60	
					609	913	1218					2.15	1308	140TC	LF-926-20-B7-J	GLF2026BJ	884	GB	60	
70	25:1				924	1232	1848					3.85	2383	180TC	LF-932-20-B9-G	GLF2032CG	1,289	GB	100	
		156	296	312								0.51	318	56C	LF-915-25-B5-G	GLF2515AG	509	GB	30	
			183	277	416							0.80	444	56C	LF-918-25-B5-B	GLF2518AG	522	GB	32	
			250	379	549							0.89	675	56C	LF-921-25-B5-G	GLF2521AG	644	GB	38	
			250	379	569							0.89	675	56C	LF-921-25-B5-J	GLF2521AJ	644	GB	38	
					567	756	1134					1.73	1307	56C	LF-926-25-B5-G	GLF2526AG	884	GB	60	
					567	756	1134					1.73	1307	140TC	LF-926-25-B7-G	GLF2526BG	884	GB	60	
					567	756	1134					1.73	1307	140TC	LF-926-25-B7-J	GLF2526BJ	884	GB	60	
							1134	1513	2269				3.13	2355	140TC	LF-932-25-B7-G	GLF2532BG	1,289	GB	100
							1134	1513	2269				3.13	2355	180TC	LF-932-25-B9-G	GLF2532CG	1,289	GB	100
58	30:1		148	195							0.42	248	56C	LF-913-30-B5-G	GLF3013AG	468	GB	20		
			159	210	318							0.50	318	56C	LF-915-30-B5-G	GLF3015AG	509	GB	30	
				216	327							0.72	470	56C	LF-918-30-B5-G	GLF3018AG	522	GB	32	
				216	327							0.72	470	56C	LF-918-30-B5-J	GLF3018AJ	522	GB	32	
				275	416	624						0.83	691	56C	LF-921-30-B5-G	GLF3021AG	644	GB	38	
				420	630	840						1.32	1111	56C	LF-924-30-B5-G	GLF3024AG	757	GB	45	
					641	854	1281					1.54	1313	140TC	LF-926-30-B7-G	GLF3026BG	884	GB	60	
					641	854	1281					1.54	1313	140TC	LF-926-30-B7-J	GLF3026BJ	884	GB	60	
						881	1322	1763				2.81	2482	180TC	LF-932-30-B9-G	GLF3032CG	1,289	GB	100	
							1626	2438				3.97	3226	180TC	LF-938-30-B9-G	GLF3038CG	1,574	GB	130	
44	40:1		180	238	360						0.64	461	56C	LF-918-40-B5-G	GLF4018AG	522	GB	32		
				521	781							0.99	1030	56C	LF-924-40-B5-G	GLF4024AG	757	GB	45	
				524	786	1049						1.23	1296	56C	LF-926-40-B5-G	GLF4026AG	884	GB	60	
					1180	1620	2160					2.20	2374	140TC	LF-932-40-B7-G	GLF4032BG	1,289	GB	100	
35	50:1				1596	2129	3192				3.00	3192	180TC	LF-938-40-B9-G	GLF4038CG	1,574	GB	130		
		280	370	561							0.58	651	56C	LF-921-50-B5-G	GLF5021AG	644	GB	38		
				621	932	1242					1.00	1242	56C	LF-926-50-B5-G	GLF5026AG	884	GB	60		
29	60:1		218	288							0.33	288	56C	LF-915-60-B5-G	GLF6015AG	509	GB	30		
			220	290							0.47	413	56C	LF-918-60-B5-G	GLF6018AG	522	GB	32		
			317	418	634						0.50	634	56C	LF-921-60-B5-G	GLF6021AG	644	GB	38		
				473	716	1074					0.82	1166	56C	LF-926-60-B5-G	GLF6026AG	884	GB	60		
					1100	1467	2200					1.54	2255	56C	LF-932-60-B5-G	GLF6032AG	1,289	GB	100	
					1100	1467	2200					1.54	2255	140TC	LF-932-60-B7-G	GLF6032BG	1,289	GB	100	

NOTE: Service Class I Torque Ratings (1.0 Service Factor)
 Service Class II Torque Ratings (≥ 1.4 Service Factor)
 Service Class III Torque Ratings (≥ 2.0 Service Factor)

Suffix G = Left hand output facing input
 J = Right hand output facing input
 H = Double Output Shaft

Vertical motor below gearhead not recommended.
 Avoiding those positions where the high speed oil seal is immersed in oil, will provide greater security against high speed input seal wear.

Assembly Types

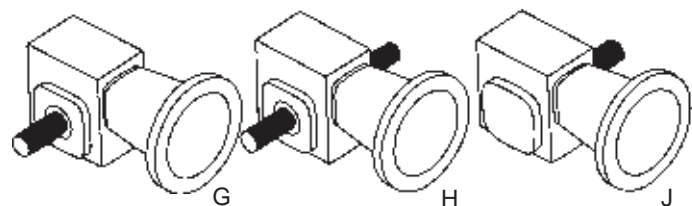

900 Series – Right Angle – Solid Shaft



GS3018G Shown

1.33 thru 2.62 CD

Applications: Ideal for conveyors, material handling, textile machines, packaging machinery and more. Suitable for direct coupling or belted input (slow speed and high torque).

Features: Heavy duty cast iron housings, chill cast bronze gears, precision ground hardened worm, ball bearings on input shaft, tapered roller bearings on output shaft. Industry-standard mounting dimensions. Pre-filled with food grade (H1) Klubersynth UH1-6-460 synthetic oil, sealed housing provides maintenance-free lubed for life operation.

Nominal Output RPM @ 1750 RPM In	Gear Ratio	Continuous Duty Output Torque (In-Lbs) Based on 1750 RPM Motor									Max Input Hp	Max Output Torque Rating In-Lbs	Style Number	Catalog Number	List Price	Mult. Sym.	Ap'x Shpg. Wgt.		
		0.25	0.33	0.5	0.75	1	1.5	2	3	5								7.5	
175	10:1				214	285	428					1.50	428	S-918-10-G	GS1018G	437	GB	25	
						312	468	624				2.02	630	S-921-10-G	GS1021G	515	GB	28	
								492	655				3.59	1177	S-926-10-G	GS1026G	725	GB	50
117	15:1	96	127	193								0.66	225	S-915-15-G	GS1515G	431	GB	21	
				209	314	419							1.07	448	S-918-15-G	GS1518G	437	GB	25
				246	369	492							1.35	664	S-921-15-G	GS1521G	515	GB	28
88	20:1	165	251	376								0.92	461	S-918-20-G	GS2018G	437	GB	25	
				323	484	645							1.06	684	S-921-20-G	GS2021G	515	GB	28
					451	602	902						1.72	1038	S-924-20-G	GS2024G	642	GB	38
						609	913	1218					2.15	1308	S-926-20-G	GS2026G	725	GB	50
		156	206	312									0.51	318	S-915-25-G	GS2515G	431	GB	21
58	30:1	148	195									0.42	248	S-913-30-G	GS3013G	418	GB	18	
			216	327									0.72	470	S-918-30-G	GS3018G	437	GB	25
			275	416	624								0.83	691	S-921-30-G	GS3021G	515	GB	28
				641	854	1281							1.54	1313	S-926-30-G	GS3026G	725	GB	50
		208	275										0.38	317	S-915-40-G	GS4015G	431	GB	21
44	40:1	180	238	360								0.64	461	S-918-40-G	GS4018G	437	GB	25	
			340	515									0.66	680	S-921-40-G	GS4021G	515	GB	28
				524	786	1049							1.23	1296	S-926-40-G	GS4026G	725	GB	50
35	50:1	222	294									0.49	436	S-918-50-G	GS5018G	437	GB	25	
		280	370	561								0.59	651	S-921-50-G	GS5021G	515	GB	28	
				621	932	1242							1.00	1242	S-926-50-G	GS5026G	725	GB	50
29	60:1	179										0.28	201	S-913-60-G	GS6013G	418	GB	18	
		218	288									0.33	288	S-915-60-G	GS6015G	431	GB	21	
		220	290									0.47	413	S-918-60-G	GS6018G	437	GB	25	
		317	418	634									0.50	634	S-921-60-G	GS6021G	515	GB	28
			458	693									0.69	958	S-924-60-G	GS6024G	642	GB	38
			473	716	1074								0.82	1166	S-926-60-G	GS6026G	725	GB	50

NOTE: Service Class I Torque Ratings (1.0 Service Factor)
 Service Class II Torque Ratings (≥ 1.4 Service Factor)
 Service Class III Torque Ratings (≥ 2.0 Service Factor)

Optional Shaft Positions and Base Installation available through Mod Express.
Refer to a Baldor District Office for pricing and delivery.
See notes on inside back flap and pages 5-6.

Vertical motor below gearhead not recommended.
Avoiding those positions where the high speed oil seal is immersed in oil, will provide greater security against high speed input seal wear.

1/4 Horsepower Stock Gear-Motors



Baldor has pre-selected and assembled our stock 900 Series* speed reducers to our most stock popular single-phase, three-phase and DC Industrial motors. These pre-assembled *Gear-Motors* offer a variety of output torques and output speeds to fit most industrial applications. To order select the desired output speed and torque or speed and input horsepower, then choose the corresponding Baldor catalog number. Your *Gear-Motor* will ship in one package, pre-assembled from the factory within 48 hours.

RPM	Service Factor	Output Torque In. Lbs.	Max. Overhung Load Rating	Ratio	NEMA Input	Catalog Number	List Price	Mult. Sym.	Ap'x. Shpg. Wgt.
TEFC, 1 Phase 115/230 Volt									
350	4.40	37	240	5:1	56C	GF0513AGA25	738	GB	40
175	3.60	62	240	10:1	56C	GF1013AGA25	738	GB	40
117	2.60	85	240	15:1	56C	GF1513AGA25	738	GB	40
88	2.10	112	240	20:1	56C	GF2013AGA25	738	GB	40
70	2.00	119	240	25:1	56C	GF2513AGA25	738	GB	40
58	1.70	147	240	30:1	56C	GF3013AGA25	738	GB	40
44	1.30	174	240	40:1	56C	GF4013AGA25	738	GB	40
35	1.30	229	300	50:1	56C	GF5015AGA25	770	GB	45
29	1.30	218	300	60:1	56C	GF6015AGA25	770	GB	45
TEFC, 3 Phase 230/460 Volt									
350	4.40	37	240	5:1	56C	GF0513AGB25	735	GB	39
175	3.60	62	240	10:1	56C	GF1013AGB25	735	GB	39
117	2.60	85	240	15:1	56C	GF1513AGB25	735	GB	39
88	2.10	112	240	20:1	56C	GF2013AGB25	735	GB	39
70	2.00	119	240	25:1	56C	GF2513AGB25	735	GB	39
58	1.70	147	240	30:1	56C	GF3013AGB25	735	GB	39
44	1.30	174	240	40:1	56C	GF4013AGB25	735	GB	39
35	1.30	229	300	50:1	56C	GF5015AGB25	767	GB	44
29	1.30	218	300	60:1	56C	GF6015AGB25	767	GB	44
TENV, DC SCR, 90 Volts									
350	4.40	37	240	5:1	56C	GF0513AGC25	1,041	GB	44
175	3.60	62	240	10:1	56C	GF1013AGC25	1,041	GB	44
117	2.60	85	240	15:1	56C	GF1513AGC25	1,041	GB	44
88	2.10	112	240	20:1	56C	GF2013AGC25	1,041	GB	44
70	2.00	119	240	25:1	56C	GF2513AGC25	1,041	GB	44
58	1.70	147	240	30:1	56C	GF3013AGC25	1,041	GB	44
44	1.30	174	240	40:1	56C	GF4013AGC25	1,041	GB	44
35	1.30	229	300	50:1	56C	GF5015AGC25	1,073	GB	49
29	1.30	218	300	60:1	56C	GF6015AGC25	1,073	GB	49
TENV, DC SCR, 180 Volts									
350	4.40	37	240	5:1	56C	GF0513AGD25	1,041	GB	44
175	3.60	62	240	10:1	56C	GF1013AGD25	1,041	GB	44
117	2.60	85	240	15:1	56C	GF1513AGD25	1,041	GB	44
88	2.10	112	240	20:1	56C	GF2013AGD25	1,041	GB	44
70	2.00	119	240	25:1	56C	GF2513AGD25	1,041	GB	44
58	1.70	147	240	30:1	56C	GF3013AGD25	1,041	GB	44
44	1.30	174	240	40:1	56C	GF4013AGD25	1,041	GB	44
35	1.30	229	300	50:1	56C	GF5015AGD25	1,073	GB	49
29	1.30	218	300	60:1	56C	GF6015AGD25	1,073	GB	49

NOTE: *See page 360 for 900 Series features.

1/3 Horsepower Stock Gear-Motors



Baldor has pre-selected and assembled our stock 900 Series* speed reducers to our most stock popular single-phase, three-phase and DC Industrial motors. These pre-assembled *Gear-Motors* offer a variety of output torques and output speeds to fit most industrial applications. To order select the desired output speed and torque or speed and input horsepower, then choose the corresponding Baldor catalog number. Your *Gear-Motor* will ship in one package, pre-assembled from the factory within 48 hours.

RPM	Service Factor	Output Torque In. Lbs.	Max. Overhung Load Rating	Ratio	NEMA Input	Catalog Number	List Price	Mult. Sym.	Ap'x. Shpg. Wgt.
TEFC, 1 Phase 115/230 Volt									
350	3.30	49	240	5:1	56C	GF0513AGA33	771	GB	42
175	2.70	82	240	10:1	56C	GF1013AGA33	771	GB	42
117	2.00	113	240	15:1	56C	GF1513AGA33	771	GB	42
88	1.60	148	240	20:1	56C	GF2013AGA33	771	GB	42
70	1.50	157	240	25:1	56C	GF2513AGA33	771	GB	42
58	1.50	209	300	30:1	56C	GF3015AGA33	803	GB	47
44	1.90	237	600	40:1	56C	GF4018AGA33	815	GB	52
35	1.50	293	600	50:1	56C	GF5018AGA33	815	GB	52
29	1.60	289	600	60:1	56C	GF6018AGA33	815	GB	52
TEFC, 3 Phase, 230/460 Volt									
350	3.30	49	240	5:1	56C	GF0513AGB33	757	GB	42
175	2.70	82	240	10:1	56C	GF1013AGB33	757	GB	42
117	2.00	113	240	15:1	56C	GF1513AGB33	757	GB	42
88	1.60	148	240	20:1	56C	GF2013AGB33	757	GB	42
70	1.50	157	240	25:1	56C	GF2513AGB33	757	GB	42
58	1.50	209	300	30:1	56C	GF3015AGB33	789	GB	47
44	1.90	237	600	40:1	56C	GF4018AGB33	801	GB	52
35	1.50	293	600	50:1	56C	GF5018AGB33	801	GB	52
29	1.60	289	600	60:1	56C	GF6018AGB33	801	GB	52
TENV, DC SCR, 90 Volt									
350	3.30	49	240	5:1	56C	GF0513AGC33	1,074	GB	47
175	2.70	82	240	10:1	56C	GF1013AGC33	1,074	GB	47
117	2.00	113	240	15:1	56C	GF1513AGC33	1,074	GB	47
88	1.60	148	240	20:1	56C	GF2013AGC33	1,074	GB	47
70	1.50	157	240	25:1	56C	GF2513AGC33	1,074	GB	47
58	1.50	209	300	30:1	56C	GF3015AGC33	1,106	GB	52
44	1.90	237	600	40:1	56C	GF4018AGC33	1,117	GB	57
35	1.50	293	600	50:1	56C	GF5018AGC33	1,117	GB	57
29	1.60	289	600	60:1	56C	GF6018AGC33	1,117	GB	57
TENV, DC SCR, 180 Volt									
350	3.30	49	240	5:1	56C	GF0513AGD33	1,074	GB	47
175	2.70	82	240	10:1	56C	GF1013AGD33	1,074	GB	47
117	2.00	113	240	15:1	56C	GF1513AGD33	1,074	GB	47
88	1.60	148	240	20:1	56C	GF2013AGD33	1,074	GB	47
70	1.50	157	240	25:1	56C	GF2513AGD33	1,074	GB	47
58	1.50	209	300	30:1	56C	GF3015AGD33	1,106	GB	52
44	1.90	237	600	40:1	56C	GF4018AGD33	1,117	GB	57
35	1.50	293	600	50:1	56C	GF5018AGD33	1,117	GB	57
29	1.60	289	600	60:1	56C	GF6018AGD33	1,117	GB	57

NOTE: *See page 360 for 900 Series features.

1/2 Horsepower Stock Gear-Motors



Baldor has pre-selected and assembled our stock 900 Series* speed reducers to our most stock popular single-phase, three-phase and DC Industrial motors. These pre-assembled *Gear-Motors* offer a variety of output torques and output speeds to fit most industrial applications. To order select the desired output speed and torque or speed and input horsepower, then choose the corresponding Baldor catalog number. Your *Gear-Motor* will ship in one package, pre-assembled from the factory within 48 hours.

RPM	Service Factor	Output Torque In. Lbs.	Max. Overhung Load Rating	Ratio	NEMA Input	Catalog Number	List Price	Mult. Sym.	Ap'x. Shpg. Wgt.
TEFC, 1 Phase 115/230 Volt									
350	2.20	74	240	5:1	56C	GF0513AGA50	822	GB	47
175	1.80	125	240	10:1	56C	GF1013AGA50	822	GB	47
117	1.60	192	300	15:1	56C	GF1515AGA50	854	GB	52
88	1.80	250	600	20:1	56C	GF2018AGA50	866	GB	57
70	1.60	278	600	25:1	56C	GF2518AGA50	866	GB	57
58	1.40	326	600	30:1	56C	GF3018AGA50	866	GB	57
44	1.30	515	750	40:1	56C	GF4021AGA50	992	GB	62
35	1.66	610	1000	50:1	56C	GF5024AGA50	1,105	GB	67
29	1.40	694	1000	60:1	56C	GF6024AGA50	1,105	GB	67
TEFC, 3 Phase, 230/460 Volt									
350	2.20	74	240	5:1	56C	GF0513AGB50	801	GB	43
175	1.80	125	240	10:1	56C	GF1013AGB50	801	GB	43
117	1.60	192	300	15:1	56C	GF1515AGB50	833	GB	48
88	1.80	250	600	20:1	56C	GF2018AGB50	845	GB	53
70	1.60	278	600	25:1	56C	GF2518AGB50	845	GB	53
58	1.40	326	600	30:1	56C	GF3018AGB50	845	GB	53
44	1.30	515	750	40:1	56C	GF4021AGB50	971	GB	58
35	1.66	610	1000	50:1	56C	GF5024AGB50	1,084	GB	63
29	1.40	694	1000	60:1	56C	GF6024AGB50	1,084	GB	63
ENV, DC SCR, 90 Volt									
350	2.20	74	240	5:1	56C	GF0513AGC50	1,147	GB	52
175	1.80	125	240	10:1	56C	GF1013AGC50	1,147	GB	52
117	1.60	192	300	15:1	56C	GF1515AGC50	1,179	GB	57
88	1.80	250	600	20:1	56C	GF2018AGC50	1,190	GB	62
70	1.60	278	600	25:1	56C	GF2518AGC50	1,190	GB	62
58	1.40	326	600	30:1	56C	GF3018AGC50	1,190	GB	62
44	1.30	515	750	40:1	56C	GF4021AGC50	1,316	GB	67
35	1.66	610	1000	50:1	56C	GF5024AGC50	1,429	GB	72
29	1.40	694	1000	60:1	56C	GF6024AGC50	1,429	GB	72
TENV, DC SCR, 180 Volt									
350	2.20	74	240	5:1	56C	GF0513AGD50	1,147	GB	51
175	1.80	125	240	10:1	56C	GF1013AGD50	1,147	GB	51
117	1.60	192	300	15:1	56C	GF1515AGD50	1,179	GB	56
88	1.80	250	600	20:1	56C	GF2018AGD50	1,190	GB	61
70	1.60	278	600	25:1	56C	GF2518AGD50	1,190	GB	61
58	1.40	326	600	30:1	56C	GF3018AGD50	1,190	GB	61
44	1.30	515	750	40:1	56C	GF4021AGD50	1,316	GB	66
35	1.66	610	1000	50:1	56C	GF5024AGD50	1,429	GB	71
29	1.40	694	1000	60:1	56C	GF6024AGD50	1,429	GB	71

NOTE: *See page 360 for 900 Series features.

3/4 Horsepower Stock Gear-Motors



Baldor has pre-selected and assembled our stock 900 Series* speed reducers to our most stock popular single-phase, three-phase and DC Industrial motors. These pre-assembled *Gear-Motors* offer a variety of output torques and output speeds to fit most industrial applications. To order select the desired output speed and torque or speed and input horsepower, then choose the corresponding Baldor catalog number. Your *Gear-Motor* will ship in one package, pre-assembled from the factory within 48 hours.

RPM	Service Factor	Output Torque In. Lbs.	Max. Overhung Load Rating	Ratio	NEMA Input	Catalog Number	List Price	Mult. Sym.	Ap'x. Shpg. Wgt.
TEFC, 1 Phase 115/230 Volt									
350	1.50	111	240	5:1	56C	GF0513AGA75	877	GB	54
175	1.20	187	240	10:1	56C	GF1013AGA75	877	GB	54
117	1.40	360	600	15:1	56C	GF1518AGA75	921	GB	64
88	1.20	375	600	20:1	56C	GF2018AGA75	921	GB	64
70	1.20	568	750	25:1	56C	GF2521AGA75	1,047	GB	69
58	1.10	624	750	30:1	56C	GF3021AGA75	1,047	GB	69
44	1.30	780	1000	40:1	56C	GF4024AGA75	1,160	GB	74
35	1.10	916	1000	50:1	56C	GF5024AGA75	1,160	GB	74
29	1.10	1066	1000	60:1	56C	GF6026AGA75	1,160	GB	74
TEFC, 3 Phase, 230/460 Volt									
350	1.50	111	240	5:1	56C	GF0513AGB75	822	GB	45
175	1.20	187	240	10:1	56C	GF1013AGB75	822	GB	45
117	1.40	360	600	15:1	56C	GF1518AGB75	866	GB	55
88	1.20	375	600	20:1	56C	GF2018AGB75	866	GB	55
70	1.20	568	750	25:1	56C	GF2521AGB75	992	GB	60
58	1.10	624	750	30:1	56C	GF3021AGB75	992	GB	60
44	1.30	780	1000	40:1	56C	GF4024AGB75	1,105	GB	65
35	1.10	916	1000	50:1	56C	GF5024AGB75	1,105	GB	65
29	1.10	1066	1000	60:1	56C	GF6026AGB75	1,105	GB	65
TENV, DC SCR, 90 Volt									
350	1.50	111	240	5:1	56C	GF0513AGC75	1,295	GB	59
175	1.20	187	240	10:1	56C	GF1013AGC75	1,295	GB	59
117	1.40	360	600	15:1	56C	GF1518AGC75	1,338	GB	69
88	1.20	375	600	20:1	56C	GF2018AGC75	1,338	GB	69
70	1.20	568	750	25:1	56C	GF2521AGC75	1,465	GB	74
58	1.10	624	750	30:1	56C	GF3021AGC75	1,465	GB	74
44	1.30	780	1000	40:1	56C	GF4024AGC75	1,577	GB	79
35	1.10	916	1000	50:1	56C	GF5024AGC75	1,577	GB	79
29	1.10	1066	1000	60:1	56C	GF6026AGC75	1,577	GB	79
TENV, DC SCR, 180 Volt									
350	1.50	111	240	5:1	56C	GF0513AGD75	1,295	GB	59
175	1.20	187	240	10:1	56C	GF1013AGD75	1,295	GB	59
117	1.40	360	600	15:1	56C	GF1518AGD75	1,338	GB	69
88	1.20	375	600	20:1	56C	GF2018AGD75	1,338	GB	69
70	1.20	568	750	25:1	56C	GF2521AGD75	1,465	GB	74
58	1.10	624	750	30:1	56C	GF3021AGD75	1,465	GB	74
44	1.30	780	1000	40:1	56C	GF4024AGD75	1,577	GB	79
35	1.10	916	1000	50:1	56C	GF5024AGD75	1,577	GB	79
29	1.10	1066	1000	60:1	56C	GF6026AGD75	1,577	GB	79

NOTE: *See page 360 for 900 Series features.

1 Horsepower Stock Gear-Motors



Baldor has pre-selected and assembled our stock 900 Series* speed reducers to our most stock popular single-phase, three-phase and DC Industrial motors. These pre-assembled *Gear-Motors* offer a variety of output torques and output speeds to fit most industrial applications. To order select the desired output speed and torque or speed and input horsepower, then choose the corresponding Baldor catalog number. Your *Gear-Motor* will ship in one package, pre-assembled from the factory within 48 hours.

RPM	Service Factor	Output Torque In. Lbs.	Max. Overhung Load Rating	Ratio	NEMA Input	Catalog Number	List Price	Mult. Sym.	Ap'x. Shpg. Wgt.
TEFC, 1 Phase 115/230 Volt									
350	1.10	149	240	5:1	56C	GF0513AGA10	938	GB	58
175	1.50	285	600	10:1	56C	GF1018AGA10	982	GB	68
117	1.35	491	750	15:1	56C	GF1521AGA10	1,108	GB	73
88	1.70	603	1000	20:1	56C	GF2024AGA10	1,221	GB	78
70	1.40	730	1000	25:1	56C	GF2524AGA10	1,221	GB	78
58	1.30	842	1000	30:1	56C	GF3024AGA10	1,221	GB	78
44	1.20	1053	1100	40:1	56C	GF4024AGA10	1,221	GB	78
35	1.70	1131	1300	50:1	56C	GF5030AGA10	1,648	GB	106
29	1.50	1196	1300	60:1	56C	GF6030AGA10	1,648	GB	106
TEFC, 3 Phase, 230/460 Volt									
350	1.10	149	240	5:1	56C	GF0513AGB10	838	GB	50
175	1.50	285	600	10:1	56C	GF1018AGB10	882	GB	60
117	1.35	491	750	15:1	56C	GF1521AGB10	1,008	GB	65
88	1.70	603	1000	20:1	56C	GF2024AGB10	1,121	GB	70
70	1.40	730	1000	25:1	56C	GF2524AGB10	1,121	GB	70
58	1.30	842	1000	30:1	56C	GF3024AGB10	1,121	GB	70
44	1.20	1053	1100	40:1	56C	GF4024AGB10	1,121	GB	70
35	1.70	1131	1300	50:1	56C	GF5030AGB10	1,548	GB	98
29	1.50	1196	1300	60:1	56C	GF6030AGB10	1,548	GB	98
TENV, DC SCR, 90 Volt									
350	1.10	149	240	5:1	56C	GF0513AGC10	1,476	GB	64
175	1.50	285	600	10:1	56C	GF1018AGC10	1,519	GB	74
117	1.35	491	750	15:1	56C	GF1521AGC10	1,646	GB	79
88	1.70	603	1000	20:1	56C	GF2024AGC10	1,759	GB	84
70	1.40	730	1000	25:1	56C	GF2524AGC10	1,759	GB	84
58	1.30	842	1000	30:1	56C	GF3024AGC10	1,759	GB	84
44	1.20	1053	1100	40:1	56C	GF4024AGC10	1,759	GB	84
35	1.70	1131	1300	50:1	56C	GF5030AGC10	2,186	GB	112
29	1.50	1196	1300	60:1	56C	GF6030AGC10	2,186	GB	112
TENV, DC SCR, 180 Volt									
350	1.10	149	240	5:1	56C	GF0513AGD10	1,476	GB	64
175	1.50	285	600	10:1	56C	GF1018AGD10	1,519	GB	74
117	1.35	491	750	15:1	56C	GF1521AGD10	1,646	GB	79
88	1.70	603	1000	20:1	56C	GF2024AGD10	1,759	GB	84
70	1.40	730	1000	25:1	56C	GF2524AGD10	1,759	GB	84
58	1.30	842	1000	30:1	56C	GF3024AGD10	1,759	GB	84
44	1.20	1053	1100	40:1	56C	GF4024AGD10	1,759	GB	84
35	1.70	1131	1300	50:1	56C	GF5030AGD10	2,186	GB	112
29	1.50	1196	1300	60:1	56C	GF6030AGD10	2,186	GB	112

NOTE: *See page 360 for 900 Series features.

1-1/2 Horsepower Stock Gear-Motors



Baldor has pre-selected and assembled our stock 900 Series* speed reducers to our most stock popular single-phase, three-phase and DC Industrial motors. These pre-assembled *Gear-Motors* offer a variety of output torques and output speeds to fit most industrial applications. To order select the desired output speed and torque or speed and input horsepower, then choose the corresponding Baldor catalog number. Your *Gear-Motor* will ship in one package, pre-assembled from the factory within 48 hours.

RPM	Service Factor	Output Torque In. Lbs.	Max. Overhung Load Rating	Ratio	NEMA Input	Catalog Number	List Price	Mult. Sym.	Ap'x. Shpg. Wgt.
TEFC, 1 Phase 115/230 Volt									
350	1.30	240	600	5:1	56C	GF0518AGA15	1,045	GB	77
175	1.30	468	750	10:1	56C	GF1018AGA15	1,045	GB	77
117	1.40	705	1000	15:1	56C	GF1524AGA15	1,284	GB	87
88	1.10	905	1000	20:1	56C	GF2024AGA15	1,284	GB	87
70	1.20	1133	1100	25:1	140TC	GF2526BGA15	1,408	GB	102
58	1.60	1201	1300	30:1	56C	GF3030AGA15	1,711	GB	115
44	1.20	1598	1300	40:1	56C	GF4030AGA15	1,681	GB	102
35	1.20	1940	1500	50:1	140TC	GF5032BGA15	1,833	GB	134
29	1.60	1880	2000	60:1	140TC	GF6038AGA15	1,940	GB	173
TEFC, 3 Phase, 230/460 Volt									
350	1.30	240	600	5:1	56C	GF0518AGB15	929	GB	64
175	1.30	468	750	10:1	56C	GF1018AGB15	929	GB	64
117	1.40	705	1000	15:1	56C	GF1524AGB15	1,168	GB	74
88	1.10	905	1000	20:1	56C	GF2024AGB15	1,168	GB	74
70	1.20	1133	1100	25:1	140TC	GF2526BGB15	1,296	GB	89
58	1.60	1201	1300	30:1	56C	GF3030AGB15	1,595	GB	102
44	1.20	1598	1300	40:1	56C	GF4030AGB15	1,565	GB	102
35	1.20	1940	1500	50:1	56C	GF5032AGB15	1,693	GB	121
29	1.60	1880	2000	60:1	140TC	GF6038BGB15	1,997	GB	160
TENV, DC SCR, 180 Volt									
350	1.30	240	600	5:1	140TC	GF0518BGD15	2,380	GB	97
175	1.30	468	750	10:1	140TC	GF1018BGD15	2,379	GB	97
117	1.40	705	1000	15:1	140TC	GF1524BGD15	2,619	GB	107
88	1.10	905	1000	20:1	140TC	GF2024BGD15	2,619	GB	107
70	1.20	1133	1100	25:1	140TC	GF2526BGD15	2,737	GB	122
58	1.60	1201	1300	30:1	140TC	GF3030BGD15	3,046	GB	135
44	1.20	1598	1300	40:1	140TC	GF4030BGD15	3,016	GB	135
35	1.20	1940	1500	50:1	140TC	GF5032BGD15	3,144	GB	154
29	1.60	1880	2000	60:1	140TC	GF6038BGD15	3,424	GB	193

NOTE: *See page 360 for 900 Series features.

2 Horsepower Stock Gear-Motors



Baldor has pre-selected and assembled our stock 900 Series* speed reducers to our most stock popular single-phase, three-phase and DC Industrial motors. These pre-assembled *Gear-Motors* offer a variety of output torques and output speeds to fit most industrial applications. To order select the desired output torque and torque or speed and input horsepower, then choose the corresponding Baldor catalog number. Your *Gear-Motor* will ship in one package, pre-assembled from the factory within 48 hours.

RPM	Service Factor	Output Torque In. Lbs.	Max. Overhung Load Rating	Ratio	NEMA Input	Catalog Number	List Price	Mult. Sym.	Ap'x. Shpg. Wgt.
TEFC, 1 Phase 115/230 Volt									
350	1.60	327	750	5:1	140TC	GF0521BGA20	1,513	GB	84
175	1.40	654	1000	10:1	140TC	GF1024BGA20	1,626	GB	89
117	1.30	950	1100	15:1	140TC	GF1526BGA20	1,744	GB	104
88	1.10	1216	1100	20:1	140TC	GF2026BGA20	1,744	GB	104
70	1.40	1423	1300	25:1	140TC	GF2530BGA20	2,053	GB	117
58	1.20	1608	1300	30:1	140TC	GF3030BGA20	2,053	GB	117
44	1.10	2160	1500	40:1	140TC	GF4032BGA20	2,151	GB	136
35	1.30	2305	2000	50:1	140TC	GF5038BGA20	2,431	GB	175
29	1.20	2508	2000	60:1	140TC	GF6038BGA20	2,431	GB	175
TEFC, 3 Phase, 230/460 Volt									
350	1.60	327	750	5:1	140TC	GF0521BGB20	1,087	GB	77
175	1.40	654	1000	10:1	140TC	GF1024BGB20	1,200	GB	82
117	1.30	950	1100	15:1	140TC	GF1526BGB20	1,318	GB	97
88	1.10	1216	1100	20:1	140TC	GF2026BGB20	1,318	GB	97
70	1.40	1423	1300	25:1	140TC	GF2530BGB20	1,627	GB	110
58	1.20	1608	1300	30:1	140TC	GF3030BGB20	1,627	GB	110
44	1.10	2160	1500	40:1	140TC	GF4032BGB20	1,725	GB	129
35	1.30	2305	2000	50:1	140TC	GF5038BGB20	2,005	GB	168
29	1.20	2508	2000	60:1	140TC	GF6038BGB20	2,005	GB	168
TENV, DC SCR, 180 Volt									
350	1.60	327	750	5:1	140TC	GF0521BGD20	2,868	GB	109
175	1.40	654	1000	10:1	140TC	GF1024BGD20	2,981	GB	114
117	1.30	950	1100	15:1	140TC	GF1526BGD20	3,100	GB	129
88	1.10	1216	1100	20:1	140TC	GF2026BGD20	3,100	GB	129
70	1.40	1423	1300	25:1	140TC	GF2530BGD20	3,408	GB	142
58	1.20	1608	1300	30:1	140TC	GF3030BGD20	3,408	GB	142
44	1.10	2160	1500	40:1	140TC	GF4032BGD20	3,506	GB	161
35	1.30	2305	2000	50:1	140TC	GF5038BGD20	3,787	GB	200
29	1.20	2508	2000	60:1	140TC	GF6038BGD20	3,787	GB	200

NOTE: *See page 360 for 900 Series features.

Universal Series – Right Angle – Quill Type – Solid Shaft



GSF2018AA Shown

1.33 thru 3.50 CD

56C thru 180TC

Applications: Ideal for conveyors, material handling, textile machines, packaging machinery. etc. (slow speed and high torque).

Features: Heavy duty cast iron housings, forged bronze worm gears, hardened steel worms, ball bearing on input shaft, tapered roller bearings on output shaft. Integral heavy duty mounting feet cast on top and bottom of housing. Single output shaft, right hand facing input shaft. Pre-lubricated with Klubersynth UH1-6-460.

Nominal Output RPM @ 1750 RPM In	Gear Ratio	Continuous Duty Output Torque (In-Lbs) Based on 1750 RPM Motor										Max Input Hp	Max Output Torque Rating In-Lbs	NEMA Motor Mount	Style Number	Catalog Number	List Price	Mult. Sym.	Ap'x Shpg. Wgt.
		0.18	0.25	0.33	0.5	0.75	1	1.5	2	3	5								
175	10:1			109	163							0.64	207	56C	STF-133-10-A-A	GSF1013AA	571	GB	21
						245	327					1.22	396	56C	STF-175-10-A-A	GSF1018AA	625	GB	22
						245	327					1.22	396	140TC	STF-175-10-B-A	GSF1018BA	625	GB	23
						244	325	488				1.77	572	56C	STF-200-10-A-A	GSF1020AA	746	GB	30
							325	488				1.77	572	140TC	STF-200-10-B-A	GSF1020BA	746	GB	29
							325	488	651			2.44	788	140TC	STF-225-10-B-A	GSF1023BA	846	GB	32
								488	651			3.43	1109	140TC	STF-258-10-B-A	GSF1026BA	1,079	GB	46
									651	976		3.43	1109	180TC	STF-258-10-C-A	GSF1026CA	1,079	GB	55
117	15:1			119	159							0.46	221	56C	STF-133-15-A-A	GSF1513AA	571	GB	21
					159	239	359					0.87	416	56C	STF-175-15-A-A	GSF1518AA	625	GB	23
						238	357	475				1.28	605	56C	STF-200-15-A-A	GSF1520AA	746	GB	29
							359	478	717			1.84	875	56C	STF-225-15-A-A	GSF1523AA	846	GB	37
								478	717			1.84	875	140TC	STF-225-15-B-A	GSF1523BA	846	GB	33
								478	717	956		2.50	1188	140TC	STF-258-15-B-A	GSF1526BA	1,079	GB	51
									717	956		3.25	1544	140TC	STF-300-15-B-A	GSF1530BA	1,233	GB	57
									717	956	1434	3.25	1544	180TC	STF-300-15-C-A	GSF1530CA	1,233	GB	61
88	20:1		102	154	205							0.36	220	56C	STF-133-20-A-A	GSF2013AA	571	GB	24
					205	308						0.68	419	56C	STF-175-20-A-A	GSF2018AA	625	GB	23
						308	462	616				1.00	612	56C	STF-200-20-A-A	GSF2020AA	746	GB	30
						308	462	616				1.00	612	140TC	STF-200-20-B-A	GSF2020BA	746	GB	28
						309	463	617				1.35	8.28	56C	STF-225-20-A-A	GSF2023AA	846	GB	37
						309	463	617				1.35	8.28	140TC	STF-225-20-B-A	GSF2023BA	846	GB	33
							461	615	923			1.92	1174	56C	STF-258-20-A-A	GSF2026AA	1,079	GB	51
								615	923			1.92	1174	140TC	STF-258-20-B-A	GSF2026BA	1,079	GB	51
									615	923	1230	2.52	1541	140TC	STF-300-20-B-A	GSF2030BA	1,233	GB	57
										923	1230	2.52	1541	180TC	STF-300-20-C-A	GSF2030CA	1,233	GB	62
									1230	1845	3.89	2363	180TC	STF-350-20-C-A	GSF2035CA	1,691	GB	90	

NOTE: Service Class I Torque Ratings (1.0 Service Factor) See notes on inside back flap and pages 5-6.
 Service Class II Torque Ratings (≥ 1.4 Service Factor)
 Service Class III Torque Ratings (≥ 2.0 Service Factor)

Vertical motor below gearhead not recommended.
 Avoiding those positions where the high speed oil seal is immersed in oil, will provide greater security against high speed input seal wear.

Gearmotors and Gear Products

Motor Accessories

Grinders

Generators

Servo Motors and Controls

Mod Express

Baldor Education Workshops

Warranties and Sales Policies

Cross Reference and Index

Baldor Sales Offices

Universal Series – Right Angle – Quill Type – Solid Shaft continued...

Nominal Output RPM @ 1750 RPM In	Gear Ratio	Continuous Duty Output Torque (In-Lbs) Based on 1750 RPM Motor										Max Input Hp	Max Output Torque Rating In-Lbs	NEMA Motor Mount	Style Number	Catalog Number	List Price	Mult. Sym.	Ap'x Shpg. Wgt.
		0.18	0.25	0.33	0.5	0.75	1	1.5	2	3	5								
70	25:1	123	186									0.29	218	56C	STF-133-25-A-A	GSF2513AA	571	GB	21
			186	247	371							0.55	406	56C	STF-175-25-A-A	GSF2518AA	625	GB	23
				247	371	557						0.81	601	56C	STF-200-25-A-A	GSF2520AA	746	GB	29
					375	563	751					1.09	814	56C	STF-225-25-A-A	GSF2523AA	846	GB	33
							744	1114	1489			2.08	1539	140TC	STF-300-25-B-A	GSF2530BA	1,233	GB	56
58	30:1	145	218								0.24	214	56C	STF-133-30-A-A	GSF3013AA	571	GB	21	
			218	289							0.47	406	56C	STF-175-30-A-A	GSF3018AA	625	GB	22	
				289	435	652					0.77	665	56C	STF-200-30-A-A	GSF3020AA	746	GB	30	
					435	652					0.98	847	56C	STF-225-30-A-A	GSF3023AA	846	GB	33	
						435	652	869			1.35	1166	56C	STF-258-30-A-A	GSF3026AA	1,079	GB	50	
							869	1304			1.74	1501	140TC	STF-300-30-B-A	GSF3030BA	1,233	GB	57	
44	40:1										2.82	2443	140TC	STF-350-30-B-A	GSF3035BA	1,691	GB	82	
		181									0.19	206	56C	STF-133-40-A-A	GSF4013AA	571	GB	21	
		180	272	362							0.36	389	56C	STF-175-40-A-A	GSF4018AA	625	GB	11	
			272	362	543						0.52	568	56C	STF-200-40-A-A	GSF4020AA	746	GB	30	
				364	547						0.71	772	56C	STF-225-40-A-A	GSF4023AA	846	GB	33	
					545	817	1090				1.01	1095	56C	STF-258-40-A-A	GSF4026AA	1,079	GB	51	
					542	815	1087				1.36	1470	56C	STF-300-40-A-A	GSF4030AA	1,233	GB	57	
35	50:1										1.36	1470	140TC	STF-300-40-B-A	GSF4030BA	1,233	GB	57	
						1087	1630	2173			2.24	2405	140TC	STF-350-40-B-A	GSF4035BA	1,691	GB	83	
		210									0.15	191	56C	STF-133-50-A-A	GSF5013AA	571	GB	21	
		210	316								0.28	360	56C	STF-175-50-A-A	GSF5018AA	625	GB	23	
		211	317	423							0.42	536	56C	STF-200-50-A-A	GSF5020AA	746	GB	30	
			317	422							0.55	693	56C	STF-225-50-A-A	GSF5023AA	846	GB	33	
				422	634	951					0.79	995	56C	STF-258-50-A-A	GSF5026AA	1,079	GB	51	
					634	952	1270				1.07	1350	140TC	STF-300-50-B-A	GSF5030BA	1,233	GB	57	
29	60:1										1.75	2196	140TC	STF-350-50-B-A	GSF5035BA	1,691	GB	86	
		235									0.24	343	56C	STF-175-60-A-A	GSF6018AA	625	GB	23	
		234	353	470							0.36	505	56C	STF-200-60-A-A	GSF6020AA	746	GB	29	
			346	461	692						0.51	702	56C	STF-225-60-A-A	GSF6023AA	846	GB	33	
				470	706						0.69	976	56C	STF-258-60-A-A	GSF6026AA	1,079	GB	51	
					706	1059					0.84	1179	56C	STF-300-60-A-A	GSF6030AA	1,233	GB	56	
				1059	1413	2119			1.50	2128	140TC	STF-350-60-B-A	GSF6035BA	1,691	GB	83			

NOTE: Service Class I Torque Ratings (1.0 Service Factor)
 Service Class II Torque Ratings (≥ 1.4 Service Factor)
 Service Class III Torque Ratings (≥ 2.0 Service Factor)

Optional Shaft Positions, Bases Installation and Motor Mounting available through Mod Express.
Refer to Baldor District Office for Price and Delivery.
See notes on inside back flap and pages 5-6.

Vertical motor below gearhead not recommended.
Avoiding those positions where the high speed oil seal is immersed in oil, will provide greater security against high speed input seal wear.

Gearmotors and Gear Products

Motor Accessories

Grinders

Generators

Servo Motors and Controls

Mod Express

Baldor Education Workshops

Warranties and Sales Policies

Cross Reference and Index

Baldor Sales Offices

Inline Helical

4 Sizes

56C thru 250TC



Applications: Ideal for conveyors, material handling, textile machines, packaging machinery, etc. (slow speed and high torque).

Features: Baldor's new ILH (in-line helical) gearboxes have higher torque ratings in a compact design. Clamp collar 56C – 250TC offers compact C-face solution. Heavy-duty cast iron housings, hardened and ground AGMA class 11 gears for greater impact resistance and longer service life. Pre-fill for horizontal mounting to insure proper oil grade and fill level.

Nominal RPMs	Continuous Duty Output Torque (in-lbs.) Based on 1750 RPM Motors											Max Input Hp	Max Output Torque Rating In-Lbs.	NEMA	Style Number	Catalog Number	List Price	Mult. Sym.	Ap'x. Shpg. Wgt.	
	0.33	0.50	0.75	1	1.5	2	3	5	7.5	10	15									20
180				349	524	698							2.02	705	56C	HB382CN56C-9	GIF0938A	906	GB	29
					524	699	1048						4.86	1698	140TC	HB382CN140TC-9	GIF0938B	906	GB	31
					524	699	1048						4.86	1698	180TC	HB382CN180TC-9	GIF0938C	992	GB	32
							1055	1758	2637				8.79	3090	180TC	HB482CN180TC-9	GIF0948C	1,433	GB	55
										3504	5256	7007	20.17	7067	210TC	HB682CN210TC-9	GIF0968D	2,245	GB	101
124				510	766	1021							2.02	1031	56C	HB382CN56C-14	GIF1438A	906	GB	29
					766	1021	1532						3.77	1925	140TC	HB382CN56C-14	GIF1438B	906	GB	31
						1057	1586	2644					6.68	3532	180TC	HB482CN180TC-14	GIF1448C	1,433	GB	55
								2447	3670	4894			10.36	5070	180TC	HB682CN180TC-14	GIF1468C	2,245	GB	93
									2447	3670	4894		14.47	7081	210TC	HB682CN210TC-14	GIF1468D	2,245	GB	101
102																				
				468	623	935							1.84	1147	56C	HB382CN56C-18	GIF1838A	906	GB	29
					936	1248	1872						3.12	1947	140TC	HB382CN140TC-18	GIF1838B	906	GB	31
						1264	1896						4.86	3071	140TC	HB482CN140TC-18	GIF1848B	1,257	GB	54
						1264	1896	3162					5.91	3738	180TC	HB482CN180TC-18	GIF1848C	1,433	GB	85
								1776	2961	4441			9.95	5892	180TC	HB682CN180TC-18	GIF1868C	2,245	GB	93
70																				
44				465	705	1057							0.95	1339	56C	HB382CN56C-40	GIF4038A	906	GB	29
					746	1118	1491						1.12	1670	56C	HB482CN56C-40	GIF4048A	1,257	GB	52
						1486	2229	2972					2.68	3983	140TC	HB482CN140TC-40	GIF4048B	1,257	GB	54
							2718	4077	6796				5.21	7081	180TC	HB682CN180TC-40	GIF4068C	2,245	GB	93
									6710	10065	13421		11.08	14870	210TC	HB882CN210TC-40	GIF4088D	3,261	GB	178
33				691	1047	1570							0.93	1947	56C	HB383CN56C-56	GIF5638A	1,094	GB	29
					1509	2012	3017						1.98	3983	56C	HB483CN56C-56	GIF5648A	1,379	GB	52
							2601	3468	5203				3.04	5272	140TC	HB682CN140TC-50	GIF5068B	2,071	GB	92
									3655	5483	9138		5.58	10198	180TC	HB882CN180TC-50	GIF5088C	3,261	GB	178

NOTE: Service Class I Torque Ratings (1.0 Service Factor)
 Service Class II Torque Ratings (≥ 1.4 Service Factor)
 Service Class III Torque Ratings (≥ 2.0 Service Factor)

Gearmotors and Gear Products

Motor Accessories

Grinders

Generators

Servo Motors and Controls

Mod Express

Baldor Education Workshops

Warranties and Sales Policies

Cross Reference and Index

Baldor Sales Offices

Ratio Multiplier – Inline – Quill Type Solid Shaft

2 Sizes

56C thru 140TC

Applications: Reducer or Increaser. Combine with Right Angle units for high ratios. May also be used as a stand alone with optional base kits.

Features: High efficiency. Cast iron construction, universal mounting positions, and optional base mounting. Internal compression chamber eliminates breather vent. Lubricated for life with Klubersynth GH6-150.



Size	Output RPM @ 1750 RPM in.	Gear Ratio	Input Style	Output Style	Catalog Number	List Price	Mult. Sym.	Ap'x. Shpg. Wgt.	Type
1	875	2:1	56C	56C	GCF2X01AA	416	GB	19	FX1-2-B5-56C
	583	3:1	56C	56C	GCF3X01AA	416	GB	19	FX1-3-B5-56C
	438	4:1	56C	56C	GCF4X01AA	416	GB	19	FX1-4-B5-56C
	350	5:1	56C	56C	GCF5X01AA	416	GB	19	FX1-5-B5-56C
2	875	2:1	140TC	140TC	GCF2X02BB	502	GB	22	FX2-2-B7-140TC
	583	3:1	140TC	140TC	GCF3X02BB	502	GB	22	FX2-3-B7-140TC
	438	4:1	140TC	140TC	GCF4X02BB	502	GB	22	FX2-4-B7-140TC
	350	5:1	56C	140TC	GCF5X02AB	502	GB	22	FX2-5-B5-140TC
	350	5:1	140TC	140TC	GCF5X02BB	502	GB	22	FX2-5-B7-140TC

Ratings at 1750 RPM Input

Size	Ratio	Output RPM	Input Hp	Output Hp	Output Torque	Output Shaft OHL
1	2:1	875	2.06	1.96	141	173
	3:1	583	1.70	1.62	175	203
	4:1	438	1.50	1.42	205	224
	5:1	350	1.13	1.08	194	247
2	2:1	875	12.42	12.17	877	445
	3:1	583	8.68	8.42	911	445
	4:1	438	6.34	6.15	885	445
	5:1	350	5.40	5.17	931	360



Optional Base Kit

Size	Catalog Number	List Price	Mult. Sym.	Ap'x. Shpg. Wgt.
1	BRMX01	55	A8	6
2	BRMX02	97	A8	6

BRMX01 with Style SX1 Ratio Multiplier



Ratio Multiplier with F900 Series Reducer

900 Series – Right Angle Base Kits



Horizontal Base



J Base



Vertical Base



Washdown Base

Universal Series – Right Angle Base Kits



Base Description	Size (Position)	Catalog Number	List Price	Mult. Sym.	Ap'x. Shpg. Wgt.
HORIZ.	913 (A,B)	B13H71	55	A8	3
VERT. low	913 (D,F)	B13V81	97	A8	2
VERT. high	913 (C,E)	B13V91	98	A8	3
VERT. J	913 (X,Y)	B13J92	95	A8	3
HORIZ.	915 (A,B)	B15H71	39	A8	4
VERT. low	915(D,F)	B18V81	100	A8	3
VERT. high	915 (C,E)	B18V91	101	A8	3
VERT. J	915 (X,Y)	B18J92	98	A8	66
HORIZ.	918 (A,B)	B18H71	66	A8	6
VERT. low	918 (D,F)	B18V81	100	A8	3
VERT. high	918 (C,E)	B18V91	101	A8	3
VERT. J	918 (X,Y)	B18J92	98	A8	6
HORIZ.	921G (A,B)	B21GH71	69	A8	5
HORIZ.	921 (A,B)	B21H71	72	A8	6
VERT. low	921 (D,F)	B21V81	109	A8	4
VERT. high	921 (C,E)	B21V91	112	A8	6
VERT. J	921 (X,Y)	B21J92	109	A8	7
HORIZ.	924 (A,B)	B24H71	86	A8	8
VERT. low	924 (D,F)	B24V81	123	A8	4
VERT. high	924 (C,E)	B24V91	132	A8	6
VERT. J	924 (X,Y)	B24J92	123	A8	9
HORIZ.	926 (A,B)	B26H71	97	A8	9
VERT. low	926 (D,F)	B26V81	165	A8	6
VERT. high	926 (C,E)	B26V91	168	A8	9
VERT. J	926 (X,Y)	B26J92	165	A8	10
HORIZ.	930 (A,B)	B30H71	110	A8	4
VERT. low	930 (D,F)	B30V81	165	A8	8
VERT. high	930 (C,E)	B30V91	168	A8	16
HORIZ.	932 (A,B)	B32H71	131	A8	13
VERT. low	932 (D,F)	B32V81	194	A8	10
VERT. high	932 (C,E)	B32V91	199	A8	13
HORIZ.	938 (A,B)	B38H71	157	A8	15
VERT. low	938(D,F)	B38V81	234	A8	38
VERT. high	938(C,E)	B38V91	245	A8	36
Optional Washdown Base Kits					
HORIZ.	913 (A,B)	WDB13H71	72	A8	3
HORIZ.	915 (A,B)	WDB15H71	72	A8	4
HORIZ.	918 (A,B)	WDB18H71	89	A8	6
HORIZ.	921 (A,B)	WDB21H71	94	A8	6
HORIZ.	924 (A,B)	WDB24H71	102	A8	8
HORIZ.	926 (A,B)	WDB26H71	115	A8	9
HORIZ.	930 (A,B)	WDB30H71	128	A8	6
HORIZ.	932 (A,B)	WDB32H71	150	A8	13
Optional Stainless Steel Base Kits					
HORIZ.	918 (A,B)	SSB18H71	329	A8	8
HORIZ.	921 (A,B)	SSB21H71	342	A8	10
HORIZ.	926 (A,B)	SSB26H71	378	A8	13

Kit includes angle bases and hardware. Converts style STF to SVF.

Size	NEMA Flange	Catalog Number	List Price	Mult. Sym.	Ap'x. Shpg. Wgt.
133-175	56C/140TC	B1317V81	98	A8	2
200-225	56C/140TC	B2022V81	102	A8	3
258-300	56C/140TC	B2530V81	158	A8	4
258-300	180TC	B2530V91	160	A8	6
350	56C/140TC 180TC/210TC	B3500V81	184	A8	5

Gearmotors and Gear Products

Motor Accessories

Grinders

Generators

Servo Motors and Controls

Mod Express

Baldor Education Workshops

Warranties and Sales Policies

Cross Reference and Index

Baldor Sales Offices

NEMA C-Face Flange Kits (coupling type)

Flange adapts NEMA C face motors to 900 Series type S reducers. Includes flange, flexible coupling and mounting hardware.



Size	NEMA Flange	Catalog Number	List Price	Mult. Sym.	Ap'x. Shpg. Wgt
913	56C	SFL913B5	151	A8	8
915	56C	SFL918B5	151	A8	9
	140TC	SFL918B7	151	A8	8
918	56C	SFL918B5	151	A8	9
	140TC	SFL918B7	151	A8	8
921	56C	SFL921B5	169	A8	11
	140TC	SFL921B7	169	A8	11
924	56C	SFL924B5	169	A8	11
	140TC	SFL924B7	169	A8	11
926	56C	SFL926B5	217	A8	14
	140TC	SFL926B7	217	A8	15

Riser Block Kits

Riser Blocks permit the gearbox to be mounted in the most desirable position (high speed input shaft above the oil level). They mount on top of the gearbox to provide clearance between the motor and the mounting surface. Kit includes the Riser Block and attachment bolts.



Size	NEMA Flange	Catalog Number	List Price	Mult. Sym.	Ap'x. Shpg. Wgt
913	56C	RBK13B5	57	A8	5
915	56C/140TC	RBK15B5	72	A8	5
918	56C/140TC	RBK18B5	89	A8	5
921	56C/140TC	RBK21B5	115	A8	5
924	56C/140TC	RBK24B5	121	A8	5
	180TC	RBK24B9	230	A8	10
926	56C/140TC	RBK26B5	128	A8	8
	180TC	RBK26B9	279	A8	11
930	56C/140TC	RBK30B5	145	A8	15
	180TC	RBK30B9	310	A8	15
932	56C/140TC	RBK32B5	194	A8	8
	180TC	RBK32B9	384	A8	15

Torque Arm Kits

Kit includes turnbuckle and both mounting brackets. Secures hollow shaft reducer to application.



Size	Catalog Number	List Price	Mult. Sym.	Ap'x. Shpg. Wgt.
913	TA13HK	141	A8	2
918	TA18HK	156	A8	2
921	TA21HK	174	A8	2
924	TA24HK	175	A8	2
926	TA26HK	178	A8	2
930	TA30HK	182	A8	2
932	TA32HK	186	A8	2
938	TA38HK	194	A8	2

Output Flange Kits



Size	Catalog Number	List Price	Mult. Sym.	Ap'x. Shpg. Wgt.
913	FL13HK	91	A8	6
915	FL15HK	98	A8	6
918	FL18HK	102	A8	6
921	FL21HK	114	A8	3
924	FL24HK	163	A8	4
926	FL26HK	175	A8	6
930	FL30HK	182	A8	6
932	FL32HK	189	A8	12
938	FL38HK	195	A8	12

Bushing Kits for Hollow Shaft Reducers

Size	Shaft Diameter	Catalog Number	List Price	Mult. Sym.	Size	Shaft Diameter	Catalog Number	List Price	Mult. Sym.
918	3/4	BU100H012	115	A8	924/926	1-1/4	BU107H104	141	A8
	7/8	BU100H014	115	A8		1-5/16	BU107H105	141	A8
	15/16	BU100H015	131	A8	930/932	1.00	BU115H100	194	A8
924/926	15/16	BU107H015	141	A8		1-7/16	BU115H107	194	A8
	1	BU107H100	141	A8		1-1/2	BU115H108	194	A8
	1-1/8	BU107H102	141	A8		1-5/8	BU115H110	194	A8
	1-3/16	BU107H103	141	A8		1-11/16	BU115H111	194	A8
						1-3/4	BU115H112	194	A8

Double Reduction Adapter Kit



900 series double reduction units may be assembled from stock single reduction units using the adapter kits.

Catalog Number	Primary Unit ^(a)	Secondary Unit ^(b)	List Price	Mult. Sym.
DR913X913B5	913	913-B5	151	A8
DR913X918B5	913	918-B5	158	A8
DR913X921B5	913	921-B5	168	A8
DR913X924B5	913	924-B5	168	A8
DR913X926B5	913	926-B5	182	A8
DR918X924B7	918	924-B7	182	A8
DR918X926B7	918	930-B7/926-B7	189	A8
DR918X932B7	918	932-B7	189	A8
DR924X938B9	924	938-B9	189	A8

NOTE: Each adapter kit consists of: 1 Adapter; 1 Seal (Installed); 1 Shim Set; 4 Screws; 1 Bearing Cup (Installed); 4 Lock Washers; and 1 Sealant Package.

^(a) Any style except shaft mount

^(b) F and HF styles only

Bushing Kit



Reduces bore size of Quill type input shafts from 7/8 to 5/8. Sintered metal bushing with integral internal and external keys.

Catalog Number	List Price	Mult. Sym.
133-6FBA	57	A8